



PRESSURE BOOSTER SETS



Pressure Booster Sets

Let Our Excellence Be Yours

株式会社 荏原製作所



EBARA PUMPS EUROPE S.p.A.
Via Pacinotti, 32
36040 BRENDOLO (VICENZA), Italy
Phone: 0444-706811 - Fax: 0444-706950
Plants: Cles, Brendola
ebar_a_pumps@ebaraeurope.com www.ebara.it

09 - 2001



Principal EBARA Group Companies in Europe

EBARA PUMPS EUROPE S.p.A.
Via Pacinotti, 32
36040 BRENDOLO (VICENZA), Italy
Phone: 0444-706811 - Fax: 0444-706950
Plants: Cles, Brendola
ebar_a_pumps@ebaraeurope.com www.ebara.it

EBARA PUMPS UK LIMITED
Ebara House, 1 Ariel Way,
Heathrow Causeway,
Great South West Road, Hounslow,
Middlesex TW4 6JS - UK
Phone: 0208 577 1661
Fax: 0208 572 3323

EBARA ESPAÑA BOMBAS S.A.
Polígono Las Arenas, C/Alameda, 1
28320 PINTO (MADRID), Spain
Phone: 916.923.630
Fax: 916.910.818

EBARA FRANCE
Z.I. des Amandiers 39 Rue des entrepreneurs
78420 CARRIERES-SUR-SEINE, France
Phone: (1) 30865480
Fax: (1) 39131971

EBARA PUMPEN GmbH
Phillipp-Reis - Str. 15
63128 DIETZENBACH, Germany
Phone: 6074/82790
Fax: 6074/827942

Italian Branches

EBARA BARI
Via Po, 3
70026 MODUGNO (BA)
Tel. 080/5320531 - Fax: 080/5320478

EBARA CAGLIARI
Via del Fangario, 29 - 09122 CAGLIARI
Tel. 070/274281 - Fax: 070/274281

EBARA FIRENZE
Via Tevere, 100 int. 17 - Località OSMANNORO
50019 SESTO FIORENTINO (FI)
Tel. 055/3024383 - Fax: 055/3024280

EBARA MILANO
Via Magenta, 77 - 20017 RHO (MI)
Tel. 02/93507358/59 - Fax: 02/93507361

EBARA PALERMO
Via Don L. Sturzo, 181/183
ZONA INDUSTRIALE - 90044 CARINI (PA)
Tel. 091/8680840 - Fax: 091/8669790

EBARA PERUGIA
Via A. Migliorati, 47 - 06100 S. SISTO (PG)
Tel. 075/5271910 - Fax: 075/5286364

EBARA PESCARA
Via Aterno, 31 - Z. Ind.le e Com.le
66100 SAMBUCETO - S. GIOVANNI TEATINO (CH)
Tel. 085/4465145 - Fax: 085/4465171

EBARA ROMA
Via E. Ferrari, 105
00043 CIAMPINO (RM)
Tel. 06/79341516 - Fax: 06/79341628

Agency

CATANZARO
NAPOLI
PADOVA





Brendola (VI) - Italy



Cles (TN) - Italy



Haneda (Japan)



Fujisawa (Japan)



Sodegaura (Japan)

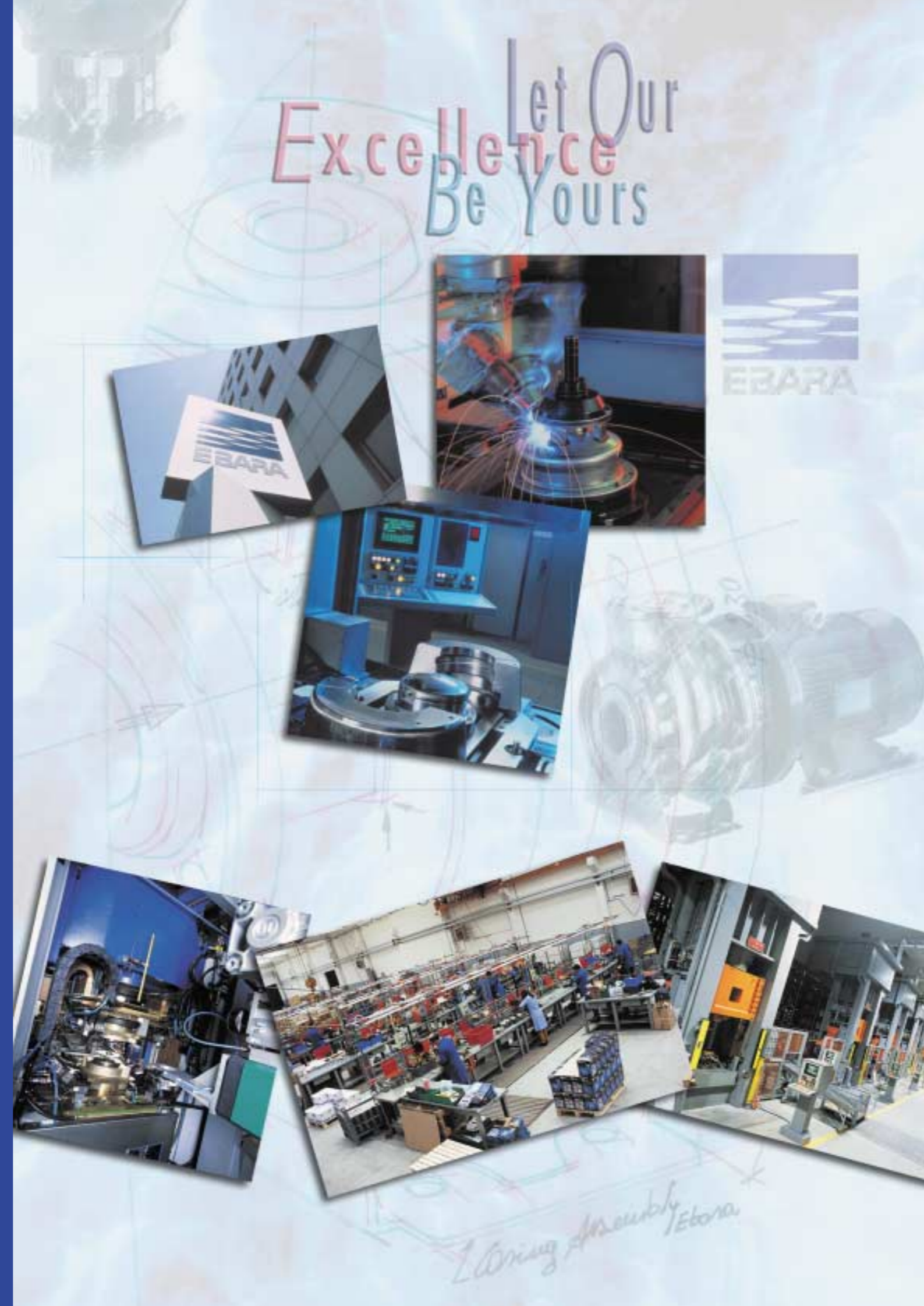

Principal EBARA Group Companies in the world

- Ebara Corporation - Japan (45 Companies)
 - Ebara Pumps Europe SpA - Italy
 - Ebara America Corporation (EAC) - USA
 - Ebara International Corporation - USA
 - Burton Mechanical Contractors, Inc. - USA
 - Ebara Technologies Inc. - USA
 - Ebara Environmental Corporation - USA
 - E & M Energy, Inc. - USA
 - Matsuzaka Company (America), Inc. - USA
 - Ebara Industrias Mecánicas e Comércio Ltda. - Brasil
 - Ebara Engineering Singapore Pte. Ltd. - Singapore
 - Ebara Kailay Environmental Eng. Co. Ltd. - Taiwan
 - Ebara Densan Taiwan Manufacturing Co., Ltd. - Taiwan
 - Ebara Benguet Inc. - Philippine
 - Ebara (Thailand) Limited. - Thailand
 - Ying Kou Ebara Co. Ltd. - China
 - Ebara Qingdao Co. Ltd. - China
 - Ebara Precision Machinery Korea Incorporated - Korea
 - Ebara Engineering (Malaysia) Sdn. Bhd. - Malaysia
 - P.T. Ebara Indonesia - Indonesia
 - Kirloskar Ebara Pumps Ltd. - India
 - Hyosung-Ebara Company Ltd. - Korea
- Other offices:
Bangkok, Beijing, Jakarta, Manila, Seoul, Taipei, Foster City, U.S.A., Scotland U.K.

EBARA PUMPS EUROPE S.p.A. reserves the right to make modification without prior notice; all specification could be subject to change.

Pressure booster sets for civic, sports, industrial and agricultural water supply systems with various surface pumps	GP	2
Pressure booster sets with two "COMPACT" series horizontal mono-block multistage pumps	2GP COMPACT	5
Pressure booster sets with two "2CDX" series horizontal mono-block pumps with stainless steel hydraulics	2GP 2CDX	8
Pressure booster sets with two "CMA-CMB-CDA" series horizontal single and twin impellers with cast iron hydraulics	2GP CMA-CMB-CDA	13
Pressure booster sets with two "MULTIGO" series vertical multistage pumps with water jacket cooling	2GP MULTIGO	18
Pressure booster sets with two vertical multistage pumps with stainless steel hydraulics "EVM" series or stainless steel hydraulics with seal holding plate and lower body in cast iron "EVM(G)"-with standard IEC Motors	2GP EVM(G)	21
Pressure booster sets with two "3M" series horizontal mono-block pumps to EN 733 (ex DIN 24255), with stainless steel hydraulics	2GP 3M	30
Pressure booster sets with two "MD" and "MMD" series horizontal mono-block pumps to EN 733 (ex DIN 24255) with cast iron hydraulics	2GP MD/MMD	35
Pressure booster sets with two "EVM" or "EVM(G)" series vertical multistage pumps with standard IEC motors as the duty pumps and 1 "EVM" stand-by pump	2+1GP EVM(G)	46
Pressure booster sets with two "3M" series horizontal mono-block pumps derived from EN 733 (ex DIN 24255) with stainless steel hydraulics as the duty pumps and 1 "2CDX" or "COMPACT" multistage pumps as stand-by pump	2+1GP 3M	53
Pressure booster sets with two "MD" or "MMD" series horizontal mono-block pumps to EN 733 (ex DIN 24255) with cast iron hydraulics as the duty pump and 1 "2CDX", "COMPACT" or "EVM" series multistage pump as the stand-by pump	2+1 GP MD/MMD	58
Pressure booster sets with three horizontal single/double rotor pumps with stainless steel "CDX-2CDX" series and cast iron "CMB-CDA" series hydraulics	3GP CDX-2CDX-CMB-CDA	69
Pressure booster sets with three multistage vertical pumps with stainless steel hydraulics "EVM" series, or with stainless steel hydraulics, cast iron lower body and seal-holding plate "EVM(G)" series - with IEC standard motor	3GP EVM(G)	73
Pressure booster sets with three horizontal mono-block pumps to EN 733 (ex DIN 24255) with stainless steel "3M" series and cast iron "MD-MMD" series hydraulics	3GP 3M-MD/MMD	80
Pressure booster sets equipped with inverter speed control	GPE	85

• All the performance curves shown in this catalogue are according ISO 9906 grade 2.

GP unit are pressure booster sets that have been developed and produced to easily and reliably meet the most arduous demand of the civic, agricultural and industrial user. The groups are prepared for connection to both diaphragm and air cushion pressure vessels.

There are three standard versions:

- **2GP** sets with two equal single phase or three phase pumps.
- **2+1 GP** sets with two equal service pumps and a small pilot that keeps the system under pressure, allowing for the make up for any drips or small demands without allowing the main duty pumps to start. The three pumps are all three phase
- **3 GP** groups with three equal three phase pumps.

MAIN COMPONENTS

Each set is made up of:

- 2 or 3 pumps, as described above (refer also to next page)
- single galvanised steel base
- galvanized steel delivery manifold, to which a further 2 vertical-type diaphragm pressure vessels can be connected
- 1 galvanized steel suction manifold (only units with MD/MMD 65 pumps are not equipped with suction manifold and relevant valves)
- suction gate and non-return valve for each pump, and possibility of connection to an air feeder (only MD/MMD 65 pumps do not have these elements)
- delivery gate valve for each pump
- CE marked control panel with fuses, overloads etc.
- pressure gauge
- 1 pressure switch for each pump

Everything is electrically, hydraulically and mechanically assembled using suitable wiring, fittings etc. ready for connection to the system and the selected pressure vessels

GROUP DESCRIPTION



The following pumps are used in the **GP** booster sets:

1° Small and medium capacity horizontal mono-blok centrifugals

- multistage with threaded connections, “Compact” series
- single/double impeller with stainless steel hydraulics, “CDX - 2CDX” series
- single/double impeller with traditional cast iron hydraulics, “CMA-CMB-CDA” series

2° Vertical multistage centrifugals

- mono-block with water chamber cooling, “Multigo” series
- with standard motor and coupling, stainless steel hydraulics, “EVM2-4-8-16-30-60” series
- with standard motor and coupling, hydraulics completely of stainless steel except for the lower body and the cast iron seal holding plate, “EVM(G) 30-60” series

3° Horizontal mono-blok centrifugals to EN 733 (ex DIN 24255)

- with stainless steel hydraulics, “3M” series
- with traditional cast iron hydraulics, “MD/MMD” series

2GP COMPACT

2GP 2CDX

2GP CMA-CMB-CDA



2+1GP EVM(G)

2+1GP 3M

2+1GP MD/MMD



3GP EVM(G)

3GP 3M-MD/MMD

3GPE





PRESSURE BOOSTER SETS WITH 2 "COMPACT" SERIES HORIZONTAL MONO-BLOCK MULTISTAGE PUMPS



TECHNICAL CHARACTERISTICS

The set base and manifolds are of galvanized steel. The delivery manifold can accept a further 2 vertical-type diaphragm tanks. 2 pressure switches, the control panel and a pressure gauge are all positioned on the manifold. Each pump has a suction gate valve, non return valve and delivery gate valve. Each pump can also be connected to an air feeder.

CE marked control panel

- Components IMQ and VDE marked.
- Very low voltage auxiliary circuit.
- Motor starting and stopping is controlled by 2 pressure switches.
- Can be connected to floats or low pressure switches to stop operation if there is no supply water.
- Equipped with a device that alternates the lead pump at each start.
- Supply:
 - single phase 230 V, 50 Hz
 - three phase 400 V, 50 Hz
- Starting:
 - direct on line
- Power circuit protection fuses
- Auxiliary circuit protection fuses
- IP 55 protection
- Door interlocked isolator
- Aut. - 0 - man. switches for each pump
- Thermal protection reset
- Pilot LED:
 - mains power
 - pump running
 - level alarm
 - pump being protected (only for three phase version)
- Special version of panels can be used upon request

WORKING PRINCIPLE

If there is a water demand while the pumps are stopped, the pressure in the system drops. As a consequence the highest-set pressure switch contact closes, and this causes the first pump to start. If the required flow is greater than the capacity of one pump, the pressure continues to drop until the second pressure switch contact closes and the second pump starts. Stopping or reducing the outgoing flow raises the system pressure, which in turn causes the pressure switch contact to open and allows the pumps to stop in turn. Alternating the starting order of the two pumps reduces the number of hourly starts of the lead pump and balances their running times. Connecting a low level float in the supply tank or a low pressure switch in the system, wired through to the control panel will protect against the most frequent cause of pump failure: dry running.

PERFORMANCE CURVES (according to ISO 9906 grade 2)

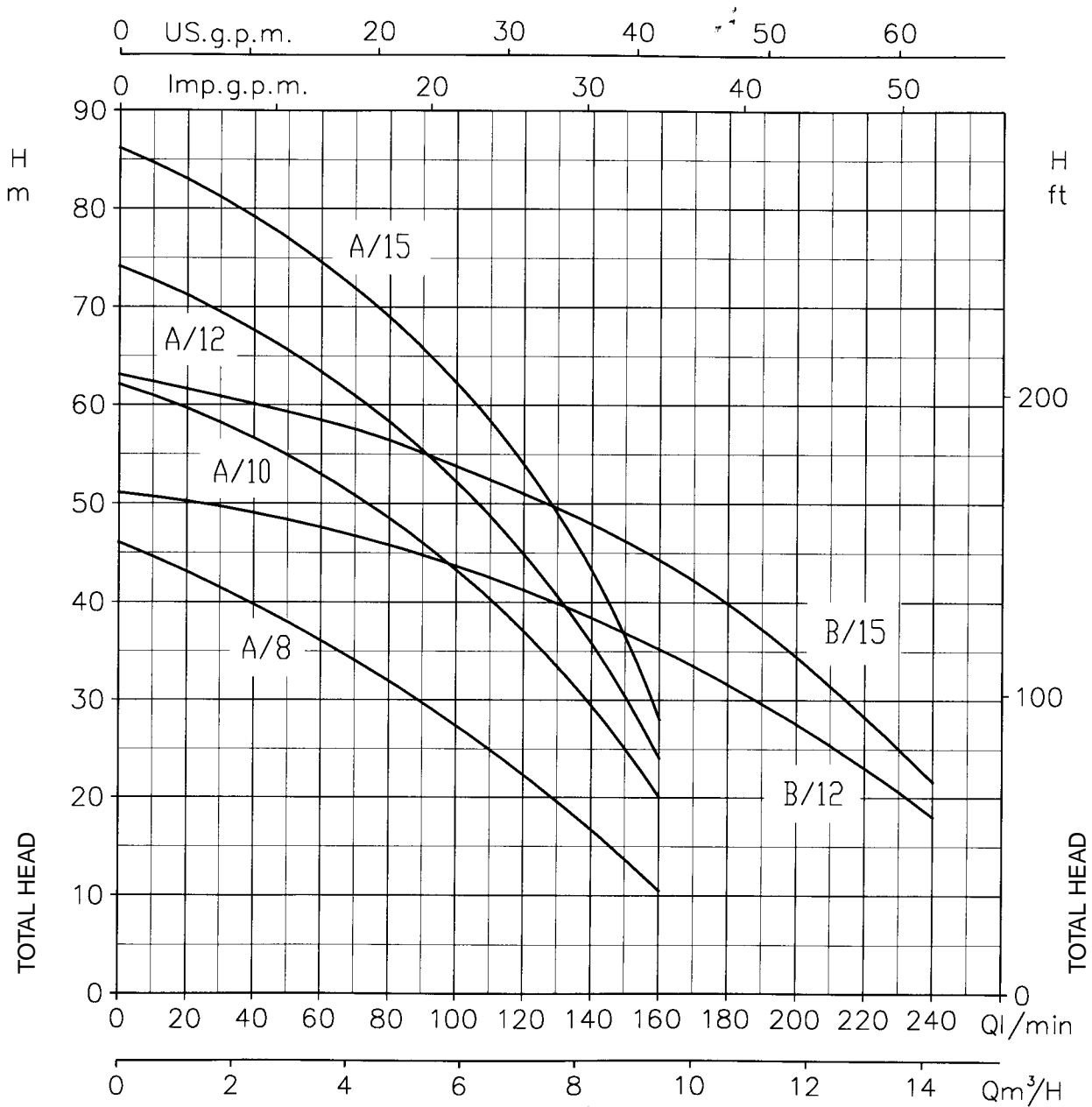

PERFORMANCE TABLE OF THE TWO PUMPS WORKING TOGETHER

PUMP TYPE		kW	Absorbed current (A)		Q=Capacity							
230 V Single phase	400 V three phase		230 V Single phase	400 V Three phase	l/min m³/h	0	40	80	120	160	200	240
Compact AM 8	Compact A 8	0,60 + 0,6	8	3	H=Total head [m]							
Compact AM 10	Compact A 10	0,75 + 0,75	12	4,8	46	39,7	32	22,4	10,5			
Compact AM 12	Compact A 12	0,88 + 0,88	12,4	5,4	62	56,5	48,6	37,1	20			
Compact AM 15	Compact A 15	1,1 + 1,1	14,6	6,6	74	67,5	58,4	44,9	24			
Compact BM 12	Compact B 12	0,88 + 0,88	11,6	5,4	86	79	69,1	54	28			
Compact BM 15	Compact B 15	1,1 + 1,1	14,6	6,8	51		45,9	41,3	35,2	27,6	18	
					63		56	51,5	44,5	34,5	22	

DIMENSIONAL DRAWINGS 2GP COMPACT

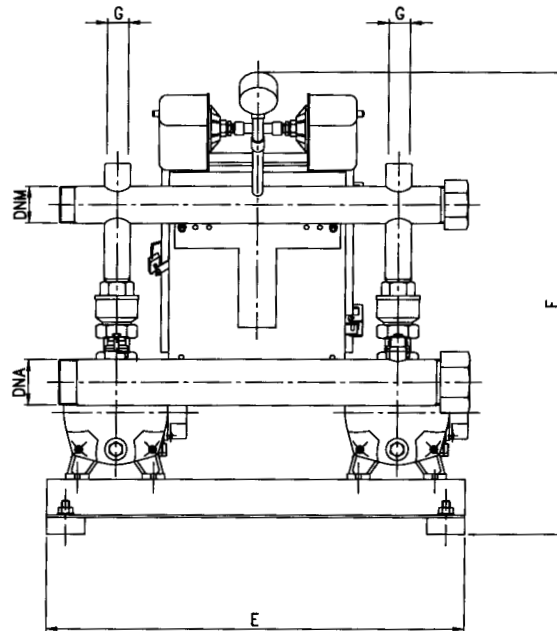
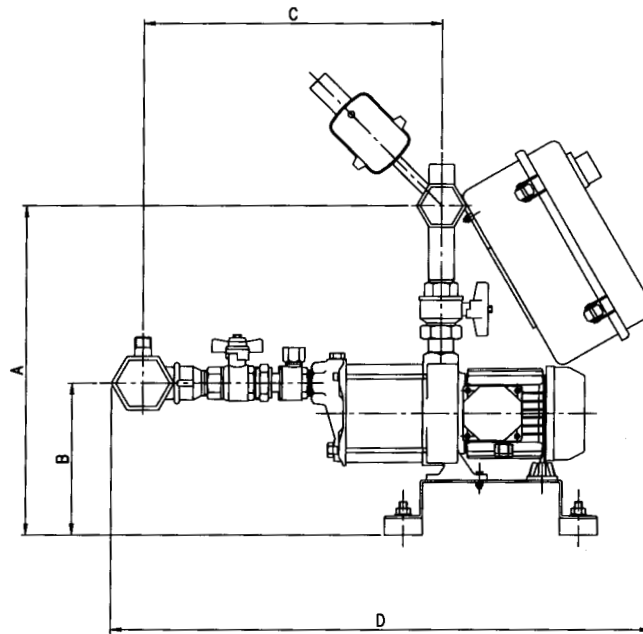

DIMENSIONAL TABLE

Model	Dimensions (mm)									
	A	B	C	D	E	F	G	H	DNA	DNM
2GP COMPACT A/8	432.5	199.5	416	735	600	606	1"F	40	2"	1 ¹ / ₂ "
2GP COMPACT A/10	432.5	199.5	442	761	600	606	1"F	40	2"	1 ¹ / ₂ "
2GP COMPACT A/12	432.5	199.5	468	787	600	606	1"F	40	2"	1 ¹ / ₂ "
2GP COMPACT A/15	432.5	199.5	494	813	600	606	1"F	40	2"	1 ¹ / ₂ "
2GP COMPACT B/12	432.5	199.5	416	735	600	606	1"F	40	2"	1 ¹ / ₂ "
2GP COMPACT B/15	432.5	199.5	442	761	600	606	1"F	40	2"	1 ¹ / ₂ "

PRESSURE BOOSTER SETS WITH 2 "2CDX" SERIES HORIZONTAL MONO-BLOCK PUMPS WITH STAINLESS STEEL HYDRAULICS



TECHNICAL CHARACTERISTICS

The set base and manifolds are of galvanized steel. The delivery manifold can accept a further 2 vertical-type diaphragm tanks. 2 pressure switches, the control panel and a pressure gauge are all positioned on the manifold. Each pump has a suction gate valve, non-return valve and delivery gate valve. Each pump can also be connected to an air feeder.

CE marked control panel

- Components IMQ and VDE marked.
- Very low voltage auxiliary circuit.
- Motor starting and stopping is controlled by 2 pressure switches.
- Can be connected to floats or low pressure switches to stop operation if there is no supply water.
- Equipped with a device that alternates the lead pump at each start.
- Supply:
 - single phase 230 V, 50 Hz
 - three phase 400 V, 50 Hz
- Starting:
 - direct on line
- Power circuit protection fuses
- Auxiliary circuit protection fuses
- IP 55 protection
- Door interlocked isolator
- Aut. - 0 - man. switches for each pump
- Thermal protection reset
- Pilot LED:
 - mains power
 - pump running
 - level alarm
 - pump being protected (only for three phase version)
- Special version of panels can be used upon request

WORKING PRINCIPLE

If there is a water demand while the pumps are stopped, the pressure in the system drops. As a consequence the highest-set pressure switch contact closes, and this causes the first pump to start. If the required flow is greater than the capacity of one pump, the pressure continues to drop until the second pressure switch contact closes and the second pump starts. Stopping or reducing the outgoing flow raises the system pressure, which in turn causes the pressure switch contact to open and allows the pumps to stop in turn. Alternating the starting order of the two pumps reduces the number of hourly starts of the lead pump and balances their running times. Connecting a low level float in the supply tank or a low pressure switch in the system, wired through to the control panel will protect against the most frequent cause of pump failure: dry running.

PERFORMANCE CURVES 2GP 2CDX 70 (according to ISO 9906 grade 2)

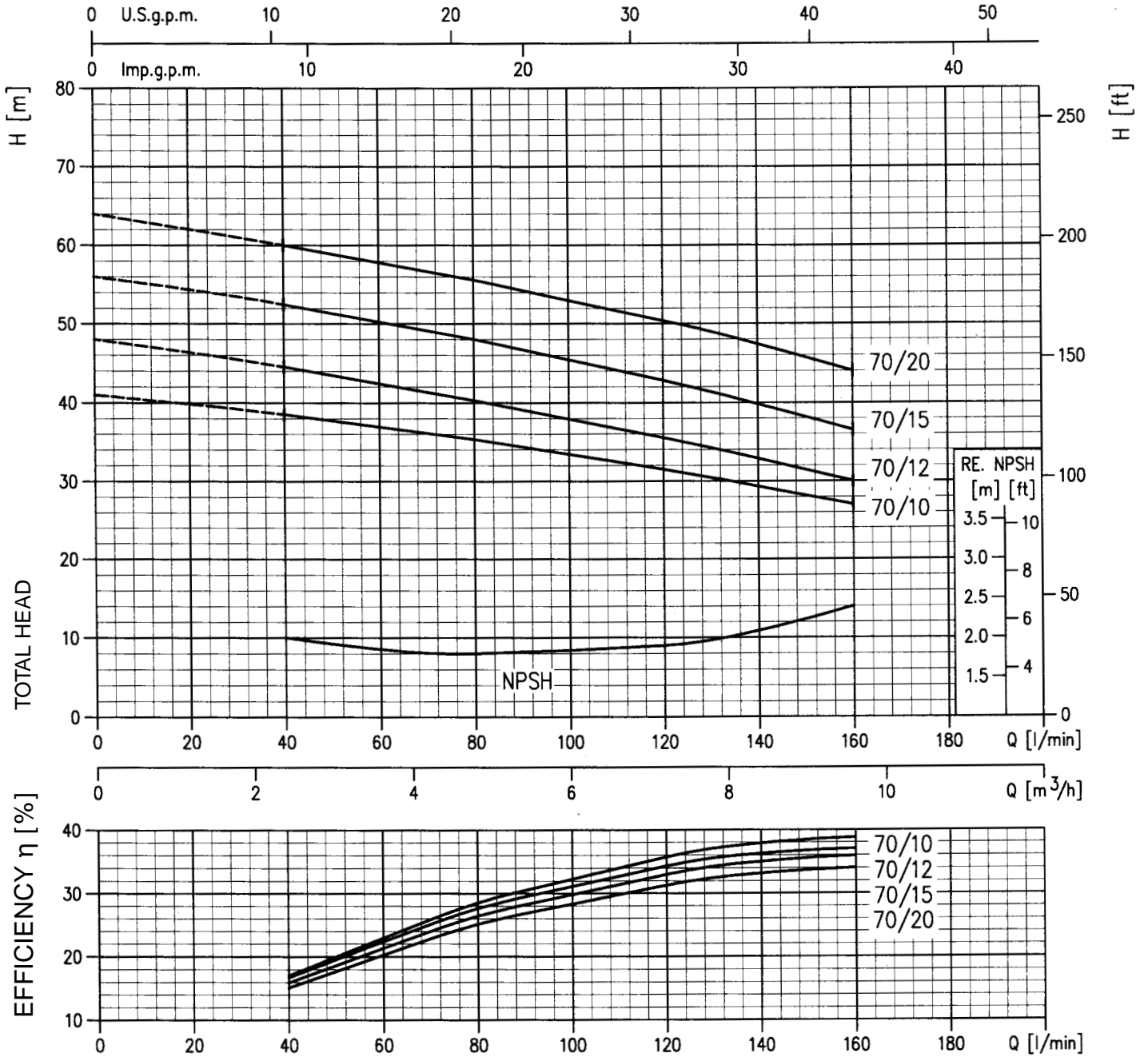

PERFORMANCE CURVES 2GP 2CDX 120 (according to ISO 9906 grade 2)

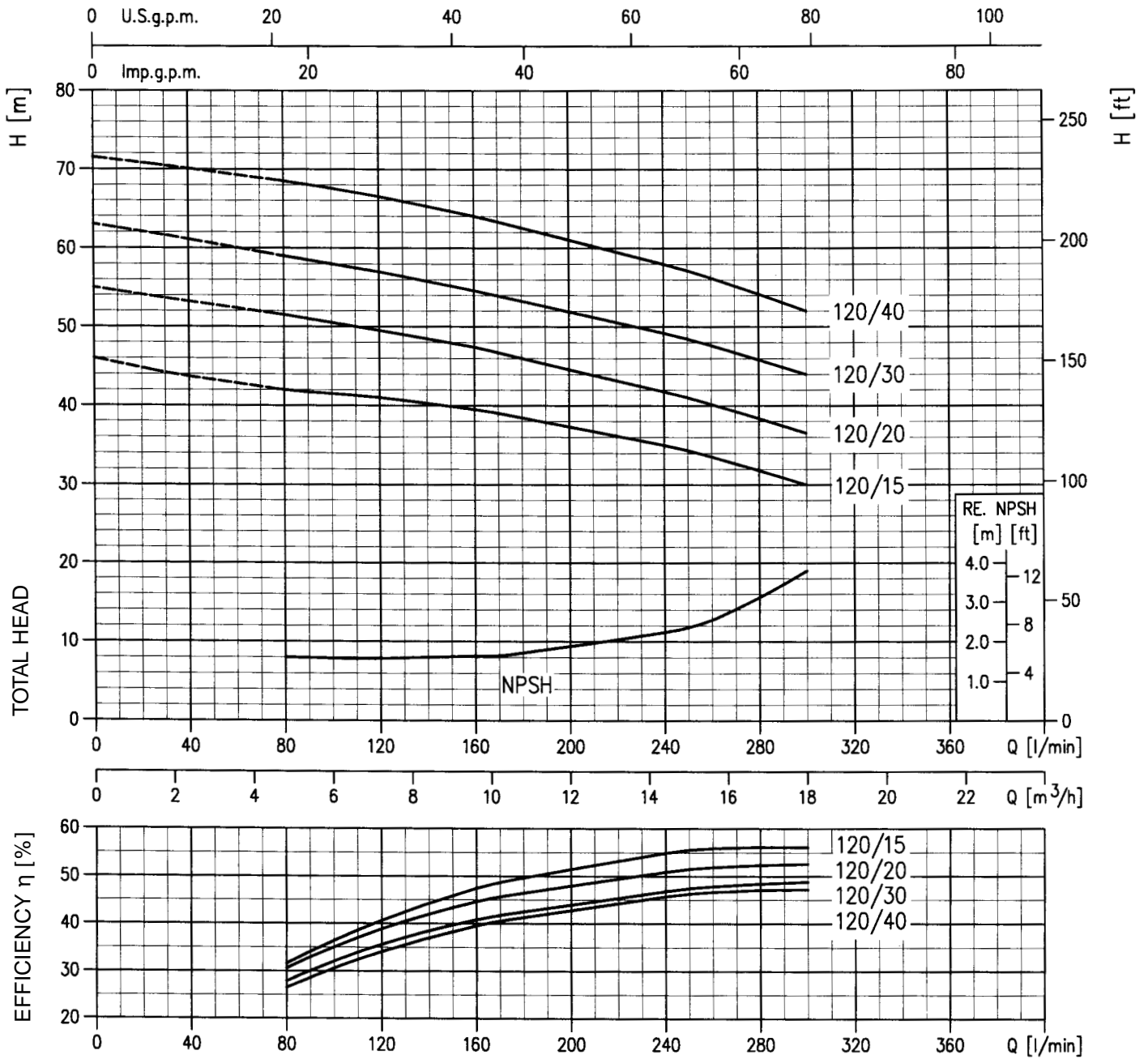

PERFORMANCE CURVES 2GP 2CDX 200 (according to ISO 9906 grade 2)

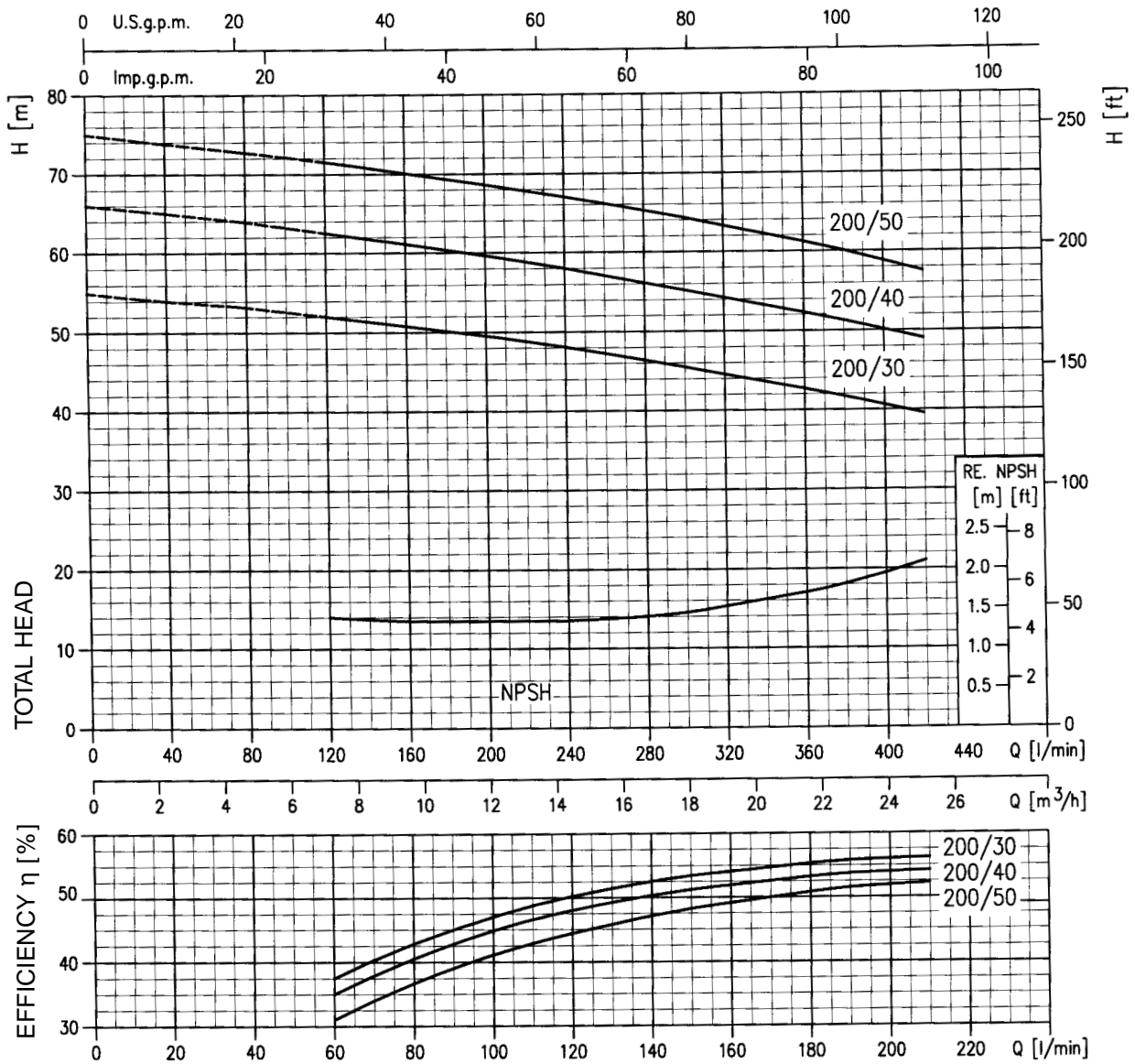

PERFORMANCE TABLE OF THE TWO PUMPS WORKING TOGETHER

Pump type		kW	Absorbed current (A)		Q=Capacity											
230 V Single phase	400 V Three phase		230 V Single phase	400 V Three phase	H = Total head [m]											
					l/min	0	40	80	120	160	200	240	300	360	420	
					m³/h	0	2,4	4,8	7,2	9,6	12	14,4	18	21,6	25,2	
2CDXM 70/10	2CDX 70/10	0,75 + 0,75	12	4,6	41	38,5	35,0	31,5	27,0							
2CDXM 70/12	2CDX 70/12	0,9 + 0,9	14	5,8	48	44,5	40,3	35,2	29,0							
2CDXM 70/15	2CDX 70/15	1,1 + 1,1	16,2	6,6	56	52,5	48,0	42,8	36,5							
2CDXM 70/20	2CDX 70/20	1,5 + 1,5	20	8	64	60,0	55,6	50,0	44,0							
2CDXM 120/15	2CDX 120/15	1,1 + 1,1	16,6	6,6	46		42,0	41,5	39,5	37,5	35,0	30,0				
2CDXM 120/20	2CDX 120/20	1,5 + 1,5	20,4	8	55		51,5	49,5	47,0	45	42,0	36,5				
	2CDX 120/30	2,2 + 2,2		10	63		59,0	57,0	54,6	52	49,0	44,0				
	2CDX 120/40	3 + 3		12,4	71,5		68,5	66,5	64,0	61	57,5	52,0				
	2CDX 200/30	2,2 + 2,2		12	55			52,0	51,0	49,5	48,0	45,5	42,6	39,5		
	2CDX 200/40	3 + 3		13,2	66			62,5	61,0	59,5	58,0	55,0	52,2	49,0		
	2CDX 200/50	3,7 + 3,7		17,4	75			71,5	70,0	68,5	67,0	64,0	61,3	57,5		

DIMENSIONAL DRAWINGS 2GP 2CDX

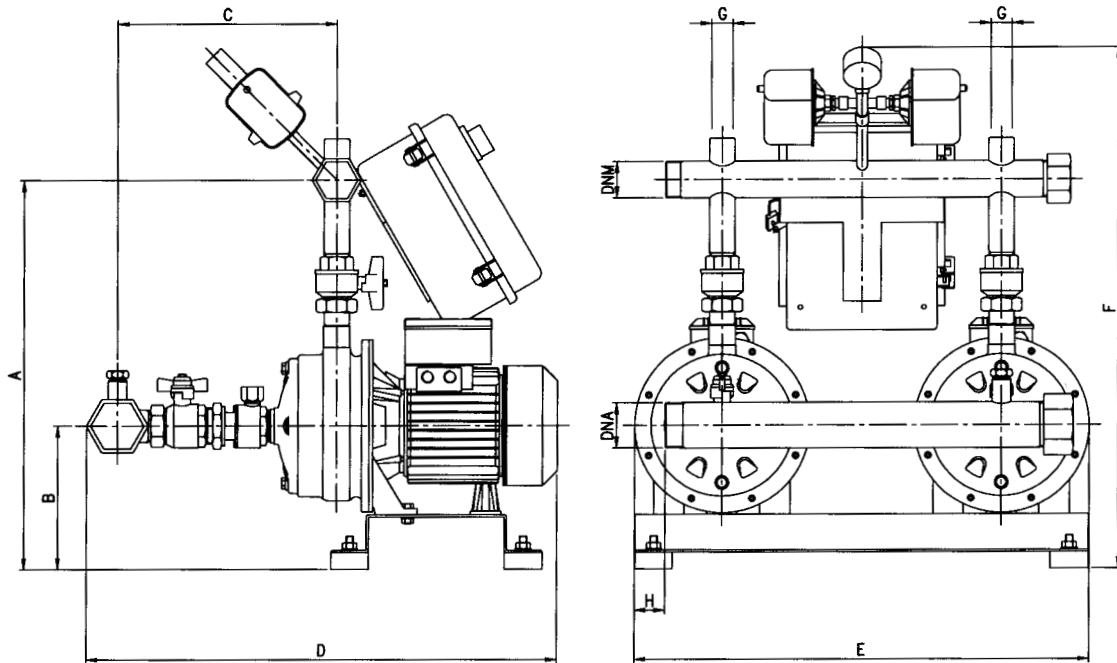

DIMENSIONAL TABLE

Model	Dimensions (mm)									
	A	B	C	D	E	F	G	H	DNA	DNM
2GP 2CDX 70/10	495	178	315	621	600	668.5	1"F	40	2"	1 ¹ / ₂ "
2GP 2CDX 70/12	495	178	315	621	600	668.5	1"F	40	2"	1 ¹ / ₂ "
2GP 2CDX 70/15	515	190	315	646	602	668.5	1"F	40	2"	1 ¹ / ₂ "
2GP 2CDX 70/20	515	190	315	646	602	668.5	1"F	40	2"	1 ¹ / ₂ "
2GP 2CDX 120/15	500.5	178	355.5	697.5	600	678	1"F	40	2 ¹ / ₂ "	2"
2GP 2CDX 120/20	500.5	178	355.5	697.5	600	678	1"F	40	2 ¹ / ₂ "	2"
2GP 2CDX 120/30	520.5	190	355.5	707.5	602	698	1"F	40	2 ¹ / ₂ "	2"
2GP 2CDX 120/40	520.5	190	355.5	732.5	602	698	1"F	40	2 ¹ / ₂ "	2"
2GP 2CDX 200/30	515.5	178	340	717	600	698.5	1"F	40	2 ¹ / ₂ "	2 ¹ / ₂ "
2GP 2CDX 200/40	535.5	190	340	717	602	718.5	1"F	40	2 ¹ / ₂ "	2 ¹ / ₂ "
2GP 2CDX 200/50	535.5	190	340	743	602	718.5	1"F	40	2 ¹ / ₂ "	2 ¹ / ₂ "

PRESSURE BOOSTER SETS WITH 2 "CMA-CMB-CDA" SERIES HORIZONTAL SINGLE-BLOCK SINGLE/DOUBLE ROTOR PUMPS WITH CAST IRON HYDRAULICS



TECHNICAL CHARACTERISTICS

The set base and manifolds are of galvanized steel. The delivery manifold can accept a further 2 vertical-type diaphragm tanks. 2 pressure switches, the control panel and a pressure gauge are all positioned on the manifold. Each pump has a suction gate valve, non-return valve and delivery gate valve. Each pump can also be connected to an air feeder.

CE marked control panel

- Components IMQ and VDE marked.
- Very low voltage auxiliary circuit.
- Motor starting and stopping is controlled by 2 pressure switches.
- Can be connected to floats or low pressure switches to stop operation if there is no supply water.
- Equipped with a device that alternates the lead pump at each start.
- Supply:
 - single phase 230 V, 50 Hz
 - three phase 400 V, 50 Hz
- Starting:
 - direct on line
- Power circuit protection fuses
- Auxiliary circuit protection fuses
- IP 55 protection
- Door interlocked isolator
- Aut. - 0 - man. switches for each pump
- Thermal protection reset
- Pilot LED:
 - mains power
 - pump running
 - level alarm
 - pump being protected (only for three phase version)
- Special version of panels can be used upon request

WORKING PRINCIPLE

If there is a water demand while the pumps are stopped, the pressure in the system drops. As a consequence the highest-set pressure switch contact closes, and this causes the first pump to start. If the required flow is greater than the capacity of one pump, the pressure continues to drop until the second pressure switch contact closes and the second pump starts. Stopping or reducing the outgoing flow raises the system pressure, which in turn causes the pressure switch contact to open and allows the pumps to stop in turn. Alternating the starting order of the two pumps reduces the number of hourly starts of the lead pump and balances their running times. Connecting a low level float in the supply tank or a low pressure switch in the system, wired through to the control panel will protect against the most frequent cause of pump failure: dry running.

PERFORMANCE CURVES 2GP CMA (according to ISO 9906 grade 2)

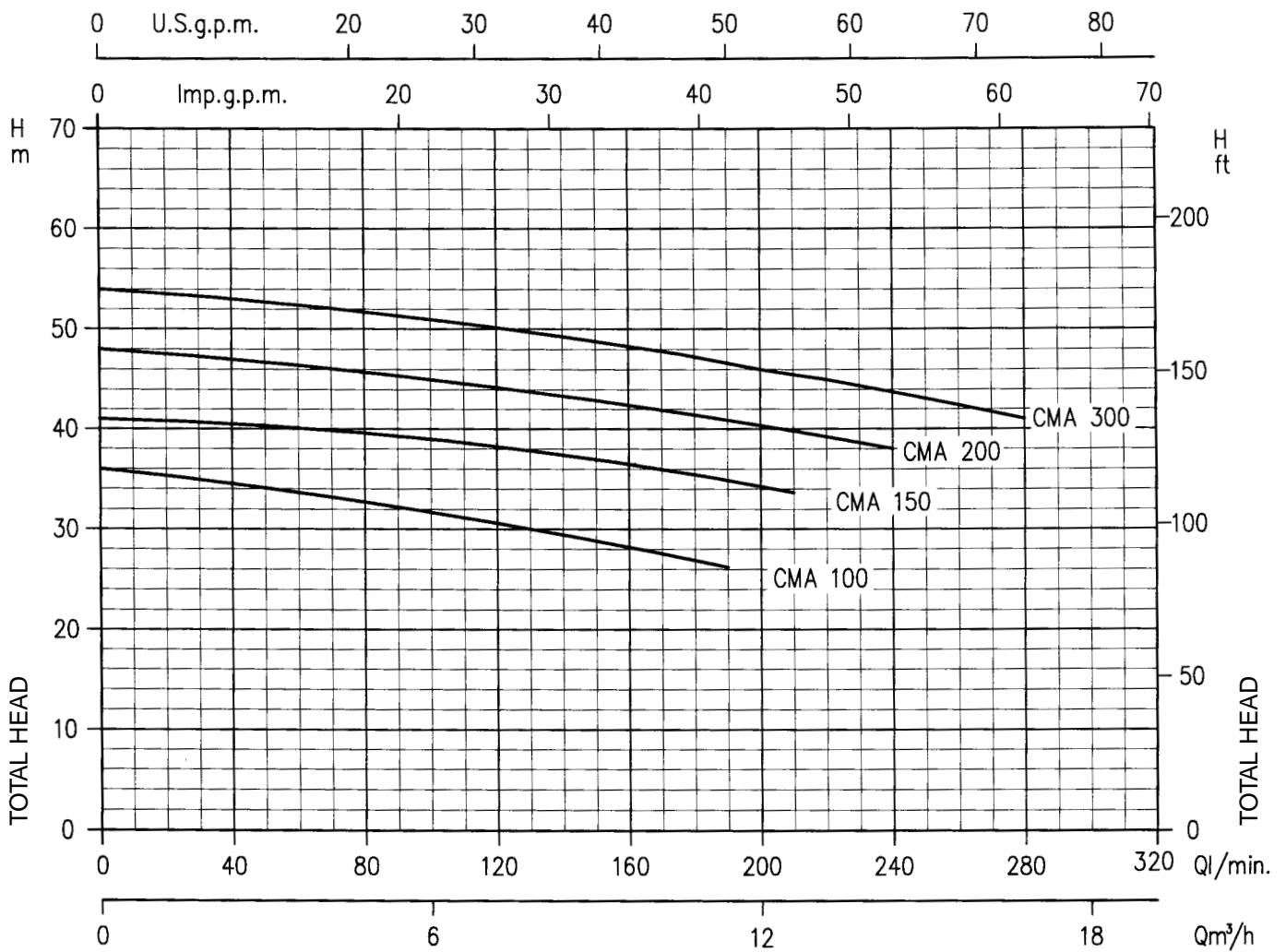

PERFORMANCE CURVES 2GP CMB (according to ISO 9906 grade 2)

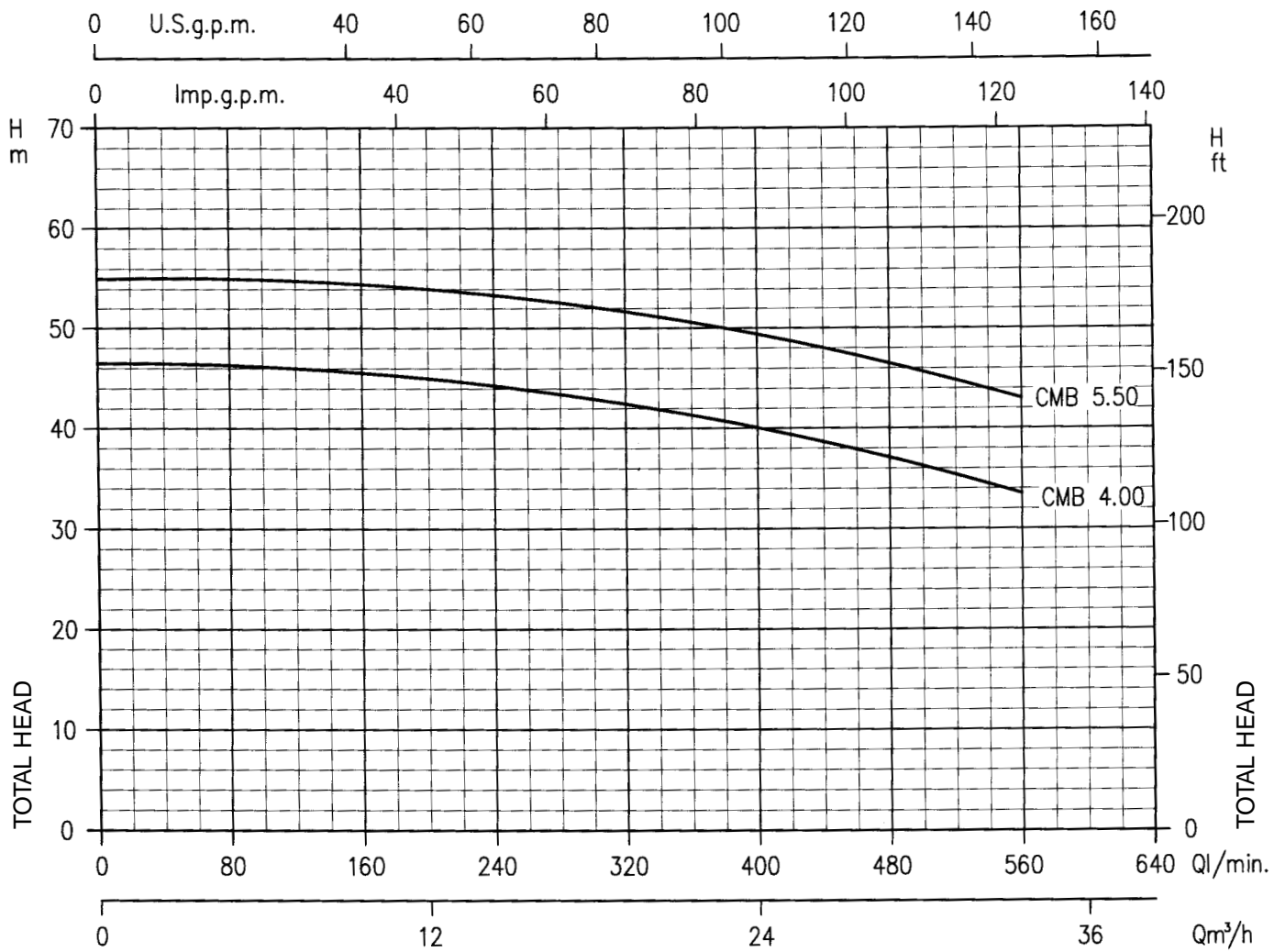

PERFORMANCE CURVES 2GP CDA (according to ISO 9906 grade 2)

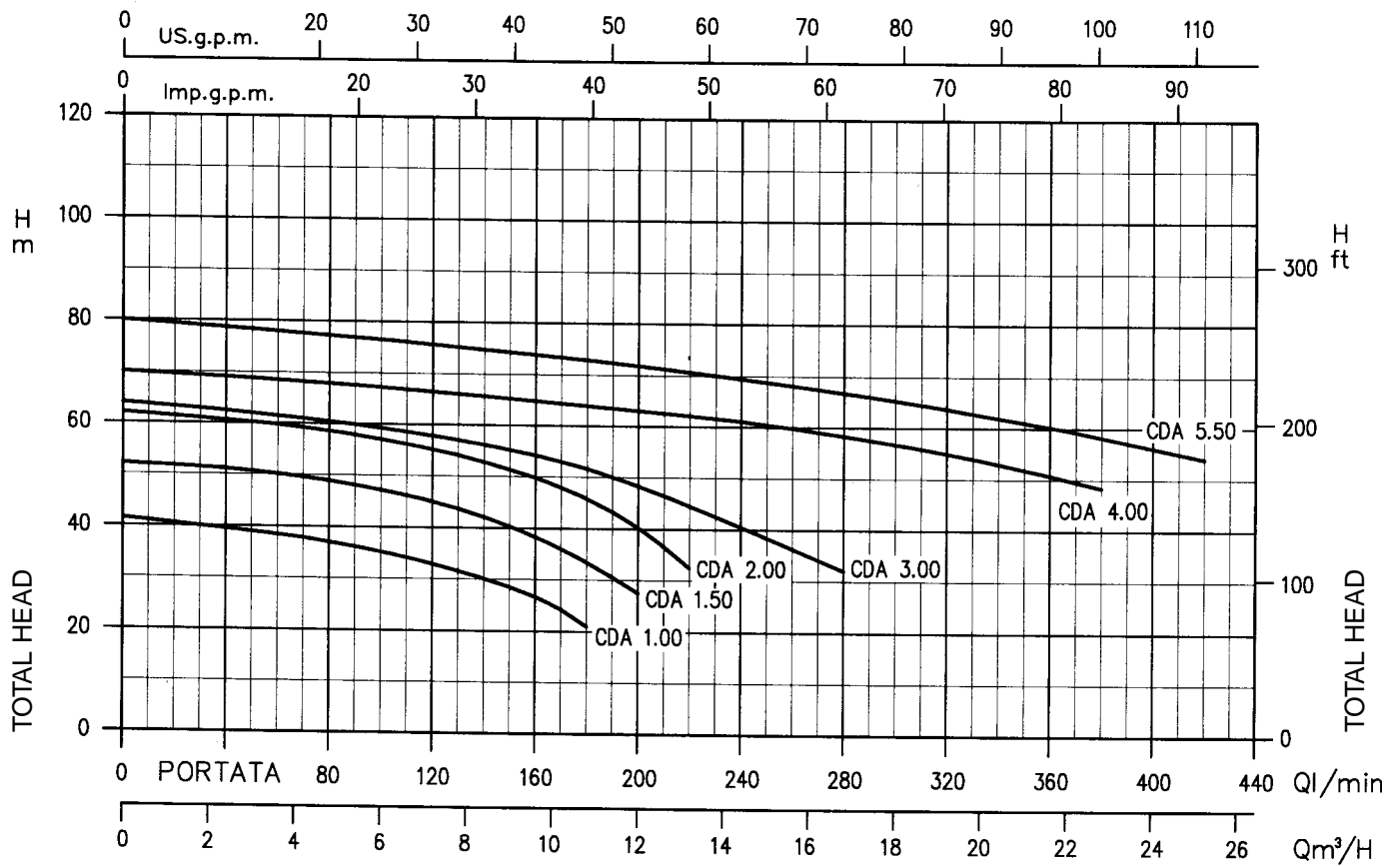

PERFORMANCE TABLE OF THE TWO PUMPS WORKING TOGETHER

Pump type		kW	Absorbed current (A)		Q=Capacity																					
230 V Single phase	400 V Three phase		230 V Single phase	400 V Three phase	l/min m³/h	0	40	80	120	160	200	240	300	360	420	500	560									
CMA 1,00M	CMA 1,00T	0,75 + 0,75	12,4	5	0	2,4	4,8	7,2	9,6	12	14,4	18	21,6	25,2	30	34										
					H = Total head [m]																					
					36	34,5	32,8	30,6	28,2	25,5																
					41	40,5	39,6	38,2	36,5	34,3																
					48	47,0	45,8	44,2	42,4	40,3	38,0															
	CMA 3,00T	2,2 + 2,2		11	54	53,0	51,8	50,2	48,3	46,2	43,7															
	CMB 4,00T	3 + 3		13,8	46,5					45,0	44,0	43,0	41,5	39	36,2	33,5										
	CMB 5,50T	4 + 4		18,4	55					54,0	53,5	52,0	50,4	48,5	45,7	43,0										
CDA 1,00M	CDA 1,00T	0,75 + 0,75	12,2	4,6	41,5	39,5	37,0	34,0	27,0																	
CDA 1,50M	CDA 1,50T	1,1 + 1,1	18	6,8	52	50,8	48,8	45,5	38,4	27,5																
CDA 2,00M	CDA 2,00T	1,5 + 1,5	21,6	8,6	62	60,5	58,6	55,5	49,8	40,3																
	CDA 3,00T	2,2 + 2,2		10,2	64		60,5	58,0	54,1	48,4	40,0															
	CDA 4,00T	3 + 3		15	70			67,0	64,8	62,5	61,0	57,0	50,0													
	CDA 5,50T	4 + 4		19	80			75,0	73,9	71,8	70,0	66,0	60,0	54,0												

DIMENSIONAL DRAWINGS 2GP CMA-CMB-CDA

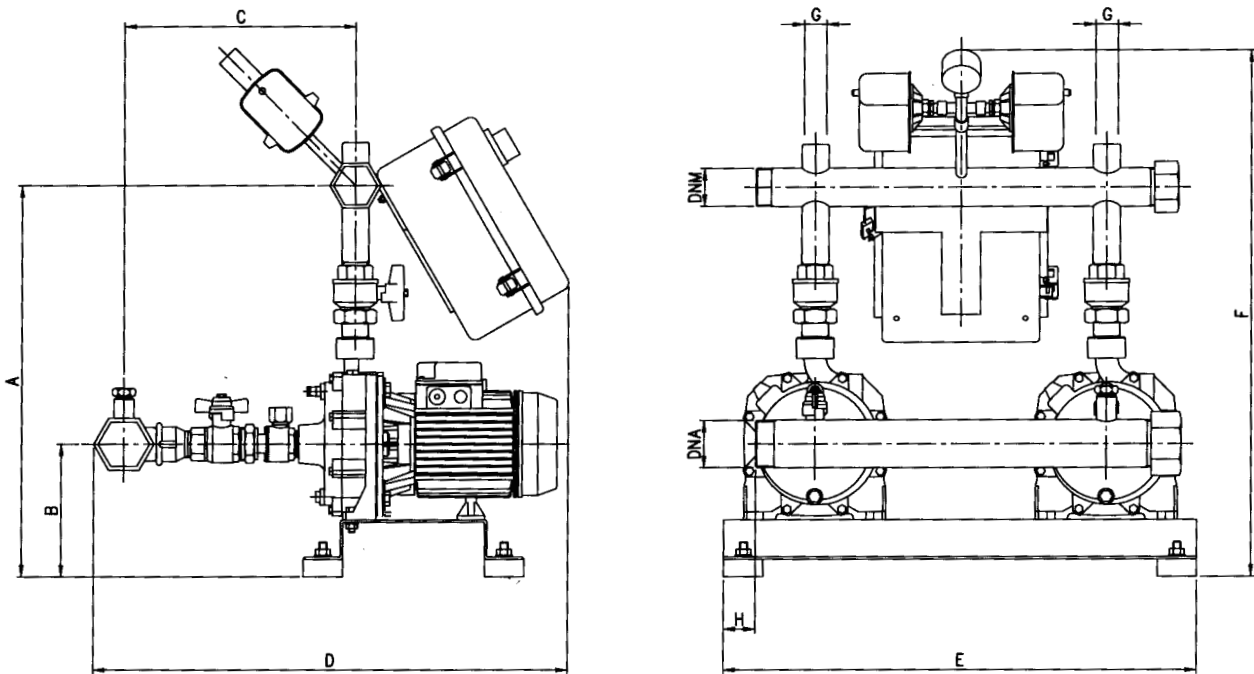

DIMENSIONAL TABLE

Model	Dimensions (mm)										Weight Kg
	A	B	C	D	E	DNA	DNM	F	G	H	
2GP CMA 100	700	700	680	167	442	2"	1 ¹ / ₂ "	750	1"F	730	38
2GP CMA 150	700	700	680	170	462	2"	1 ¹ / ₂ "	750	1"F	730	59
2GP CMA 200	700	700	680	185	496	2"	1 ¹ / ₂ "	750	1"F	730	67
2GP CMA 300	700	700	680	185	496	2"	1 ¹ / ₂ "	750	1"F	730	70
2GP CMB 400	700	720	790	202	545	3"	2"	750	1"F	730	118
2GP CMB 550	700	720	790	202	545	3"	2"	750	1"F	730	125
2GP CDA 100	700	650	790	167	437	2"	1 ¹ / ₂ "	750	1"F	730	45
2GP CDA 150	700	650	790	180	475	2"	1 ¹ / ₂ "	750	1"F	730	75
2GP CDA 200	700	650	790	180	475	2"	1 ¹ / ₂ "	750	1"F	730	81
2GP CDA 300	700	650	790	180	475	2"	1 ¹ / ₂ "	750	1"F	730	82
2GP CDA 400	700	700	830	202	535	2 ¹ / ₂ "	2"	750	1"F	730	128
2GP CDA 550	700	700	830	202	535	2 ¹ / ₂ "	2"	750	1"F	730	140

PRESSURE BOOSTER SETS WITH 2 "MULTIGO" SERIES VERTICAL SINGLE- BLOCK MULTISTAGE PUMPS WITH WATER CHAMBER COOLING



TECHNICAL CHARACTERISTICS

The set base and manifolds are of galvanized steel. The delivery manifold can accept a further 2 vertical-type diaphragm tanks. 2 pressure switches, the control panel and a pressure gauge are all positioned on the manifold. Each pump has a suction gate valve, non-return valve and delivery gate valve. Each pump can also be connected to an air feeder.

CE marked control panel

- Components IMQ and VDE marked.
- Very low voltage auxiliary circuit.
- Motor starting and stopping is controlled by 2 pressure switches.
- Can be connected to floats or low pressure switches to stop operation if there is no supply water.
- Equipped with a device that alternates the lead pump at each start.
- Supply:
 - single phase 230 V, 50 Hz
 - three phase 400 V, 50 Hz
- Starting:
 - direct on line
- Power circuit protection fuses
- Auxiliary circuit protection fuses
- IP 55 protection
- Door interlocked isolator
- Aut. - 0 - man. switches for each pump
- Thermal protection reset
- Pilot LED:
 - mains power
 - pump running
 - level alarm
 - pump being protected (only for three phase version)
- Special version of panels can be used upon request

WORKING PRINCIPLE

If there is a water demand while the pumps are stopped, the pressure in the system drops. As a consequence the highest-set pressure switch contact closes, and this causes the first pump to start. If the required flow is greater than the capacity of one pump, the pressure continues to drop until the second pressure switch contact closes and the second pump starts. Stopping or reducing the outgoing flow raises the system pressure, which in turn causes the pressure switch contact to open and allows the pumps to stop in turn. Alternating the starting order of the two pumps reduces the number of hourly starts of the lead pump and balances their running times. Connecting a low level float in the supply tank or a low pressure switch in the system, wired through to the control panel will protect against the most frequent cause of pump failure: dry running.

PERFORMANCE CURVES 2GP MULTIGO (according to ISO 9906 grade 2)

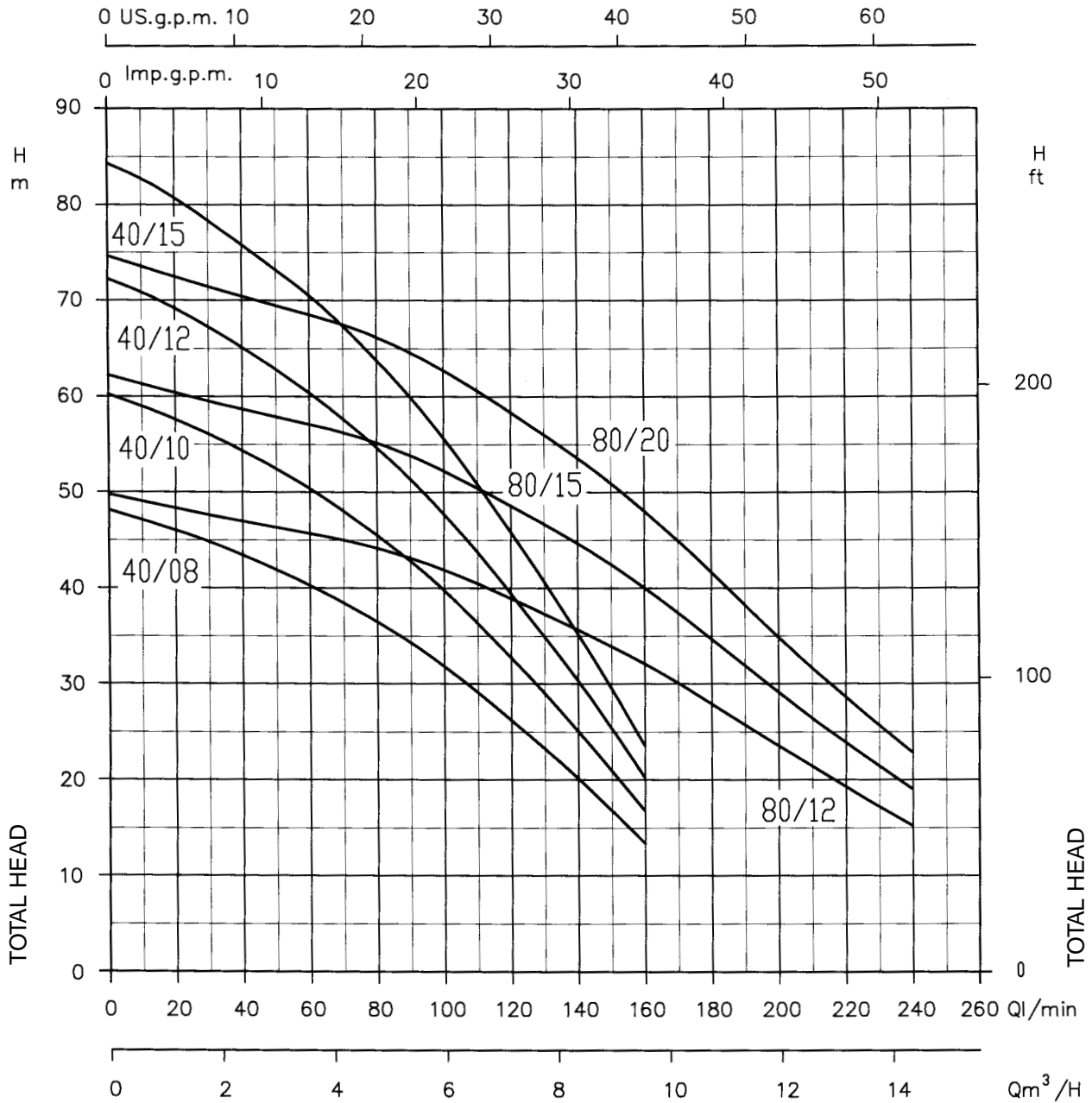

PERFORMANCE TABLE OF THE TWO PUMPS WORKING TOGETHER

Pump type		kW	Absorbed current (A)		l/min m³/h	Q=Capacity							
230 V Single phase	400 V Three phase		230 V Single phase	400 V Three phase		0	40	80	120	160	200	240	
Multigo M40/08	Multigo 40/08	0,6 + 0,6	8,6	3,8	0	2,4	4,8	7,2	9,6	12	14,4		
Multigo M40/10	Multigo 40/10	0,75 + 0,75	11,4	4,4	48	43,3	36,3	26,1	13,4				
Multigo M40/12	Multigo 40/12	0,88 + 0,88	13,6	4,8	60	54,1	45,4	32,6	16,8				
Multigo M40/15	Multigo 40/15	1,1 + 1,1	14,6	6	72	64,9	54,5	39,2	20,2				
Multigo M80/12	Multigo 80/12	0,88 + 0,88	12,8	4,6	84	75,7	63,6	45,7	23,5				
Multigo M80/15	Multigo 80/15	1,1 + 1,1	15	6,2	49,6		44,0	38,8	32,0	23,2	15,2		
	Multigo 80/20	1,5 + 1,5	7	7	62		55,0	48,5	40,0	28,0	19,0		
					74,4		66,0	58,2	48,0	34,8	22,8		

DIMENSIONAL DRAWINGS 2GP MULTIGO

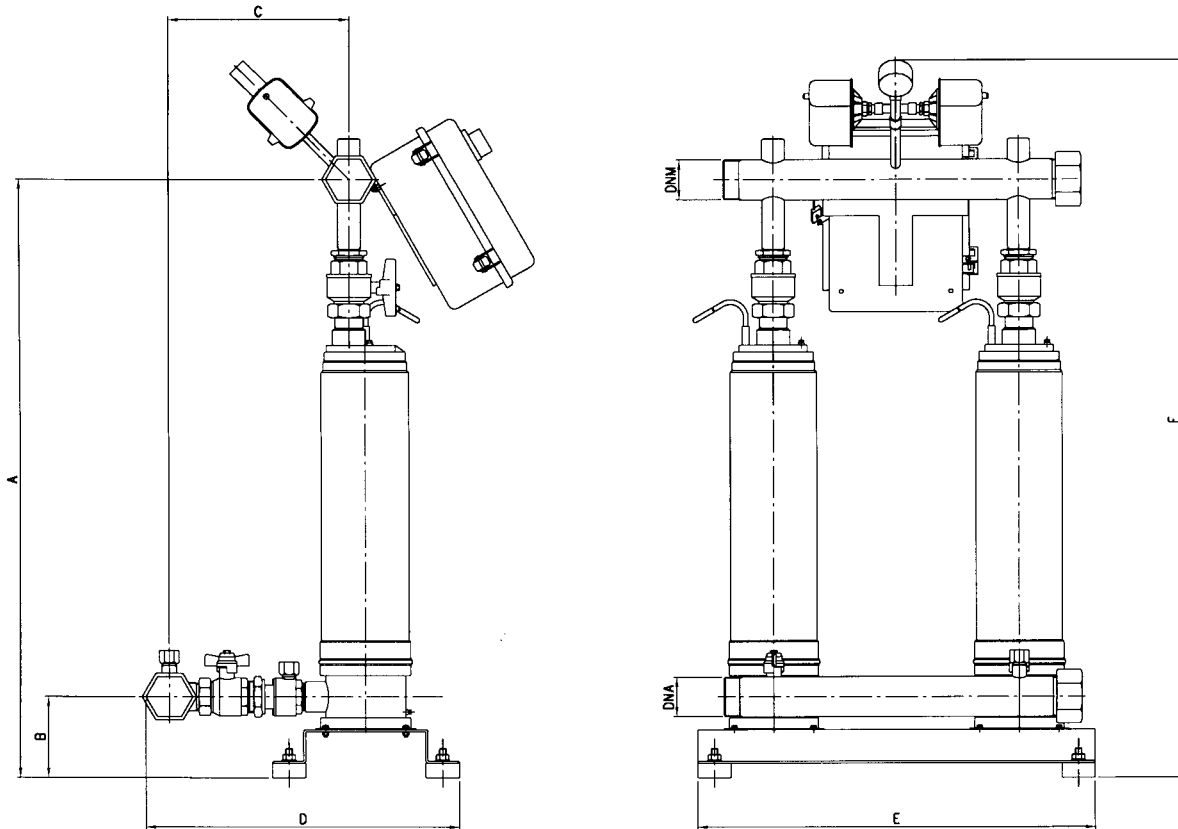

DIMENSIONAL TABLE

Model	Dimensions (mm)								
	A	B	C	D	E	F	G	DNM	DNM
2GP MULTIGO 40/08	849	122	294,5	619	600	1026.5	1"F	2"	2"
2GP MULTIGO 40/10	868	122	294,5	619	600	1045.5	1"F	2"	2"
2GP MULTIGO 40/12	919	122	294,5	619	600	1096.5	1"F	2"	2"
2GP MULTIGO 40/15	945	122	294,5	619	600	1122.5	1"F	2"	2"
2GP MULTIGO 80/12	868	122	294,5	619	600	1045.5	1"F	2"	2"
2GP MULTIGO 80/15	893	122	294,5	619	600	1070.5	1"F	2"	2"
2GP MULTIGO 80/20	919	122	294,5	619	600	1096.5	1"F	2"	2"

PRESSURE BOOSTER SETS WITH 2 VERTICAL MULTISTAGE PUMPS WITH STAINLESS STEEL HYDRAULICS "EVM" SERIES, OR STAINLESS STEEL HYDRAULICS WITH SEAL-HOLDING PLATE AND LOWER BODY IN CAST IRON "EVMG" SERIES WITH STANDARDISED MOTOR



TECHNICAL CHARACTERISTICS

The set base and manifolds are of galvanized steel. The delivery manifold can accept a further 2 vertical-type diaphragm tanks. 2 pressure switches, the control panel and a pressure gauge are all positioned on the manifold. Each pump has a suction gate valve, non-return valve and delivery gate valve. Each pump can also be connected to an air feeder.

CE marked control panel

- Components IMQ and VDE marked.
- Very low voltage auxiliary circuit.
- Motor starting and stopping is controlled by 2 pressure switches.
- Can be connected to floats or low pressure switches to stop operation if there is no supply water.
- Equipped with a device that alternates the lead pump at each start.
- Supply:
 - single phase 230 V, 50 Hz
 - three phase 400 V, 50 Hz
- Starting:
 - direct on line
- Power circuit protection fuses
- Auxiliary circuit protection fuses
- IP 55 protection
- Door interlocked isolator
- Aut. - 0 - man. switches for each pump
- Thermal protection reset
- Pilot LED:
 - mains power
 - pump running
 - level alarm
 - pump being protected (only for three phase version)
- Special version of panels can be used upon request

WORKING PRINCIPLE

If there is a water demand while the pumps are stopped, the pressure in the system drops. As a consequence the highest-set pressure switch contact closes, and this causes the first pump to start. If the required flow is greater than the capacity of one pump, the pressure continues to drop until the second pressure switch contact closes and the second pump starts. Stopping or reducing the outgoing flow raises the system pressure, which in turn causes the pressure switch contact to open and allows the pumps to stop in turn. Alternating the starting order of the two pumps reduces the number of hourly starts of the lead pump and balances their running times. Connecting a low level float in the supply tank or a low pressure switch in the system, wired through to the control panel will protect against the most frequent cause of pump failure: dry running.

PERFORMANCE CURVES 2GP EVM 2 (according to ISO 9906 grade 2)

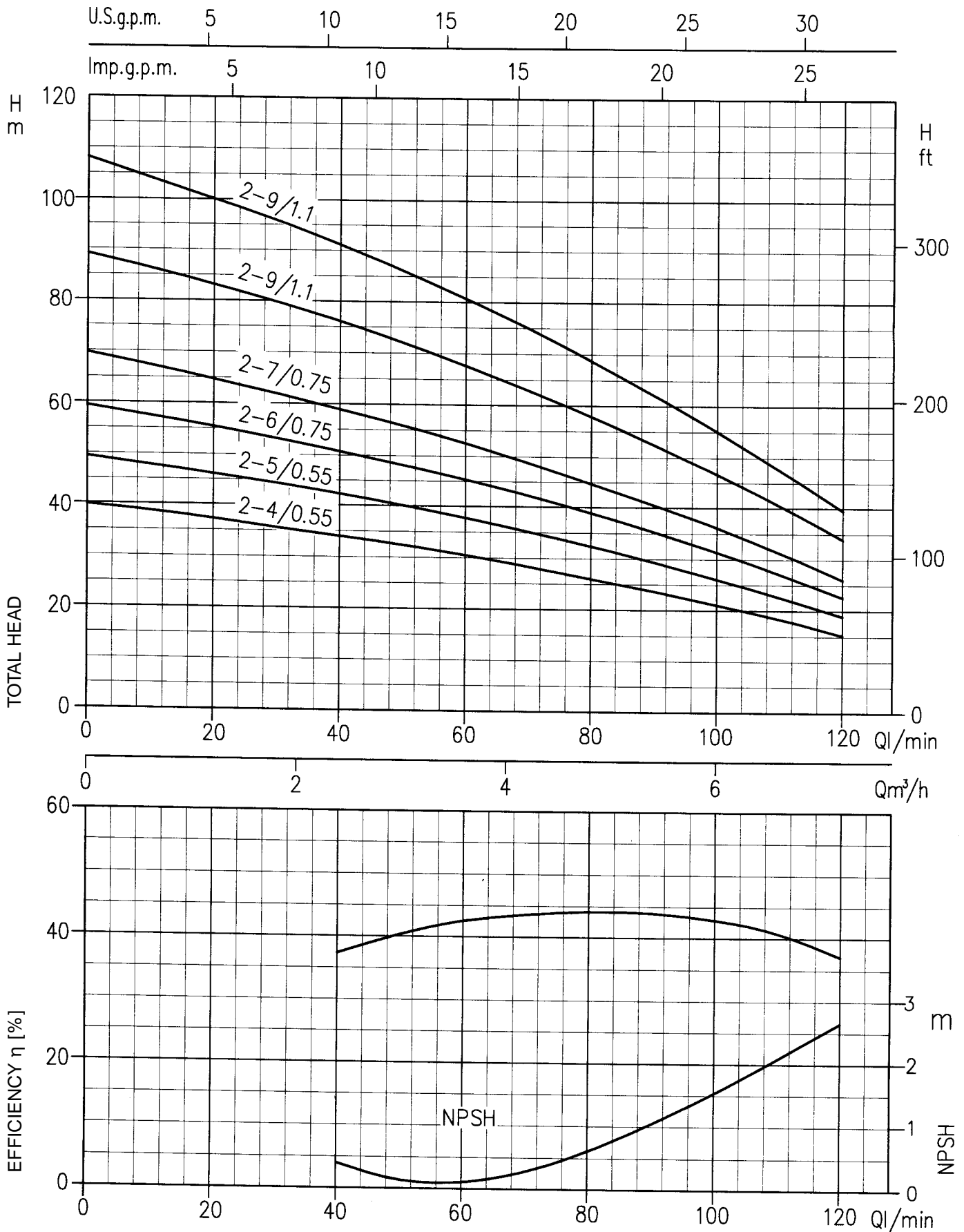

PERFORMANCE CURVES 2GP EVM 4 (according to ISO 9906 grade 2)

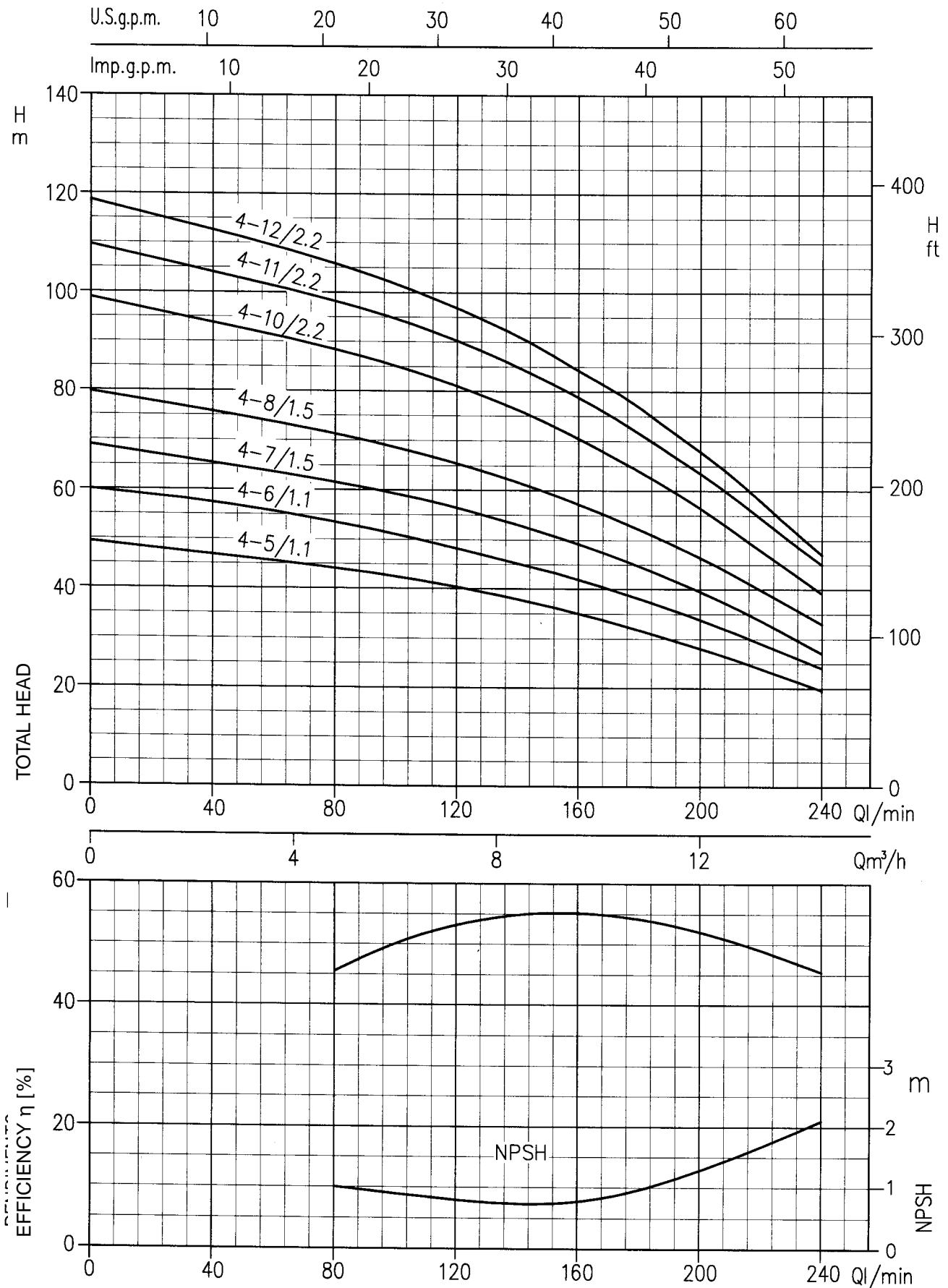

PERFORMANCE CURVES 2GP EVM 8 (according to ISO 9906 grade 2)

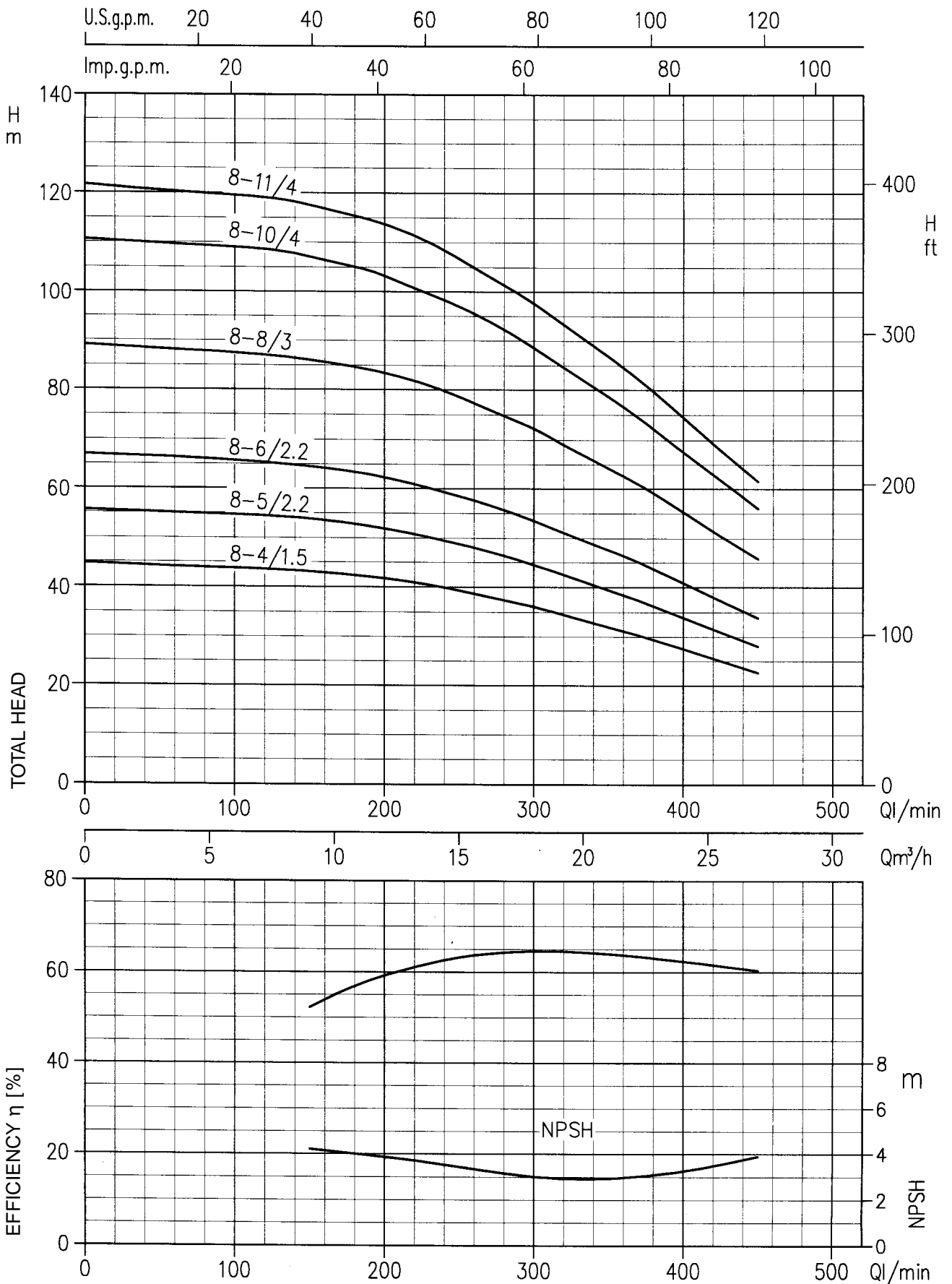

PERFORMANCE CURVES 2GP EVM 16 (according to ISO 9906 grade 2)

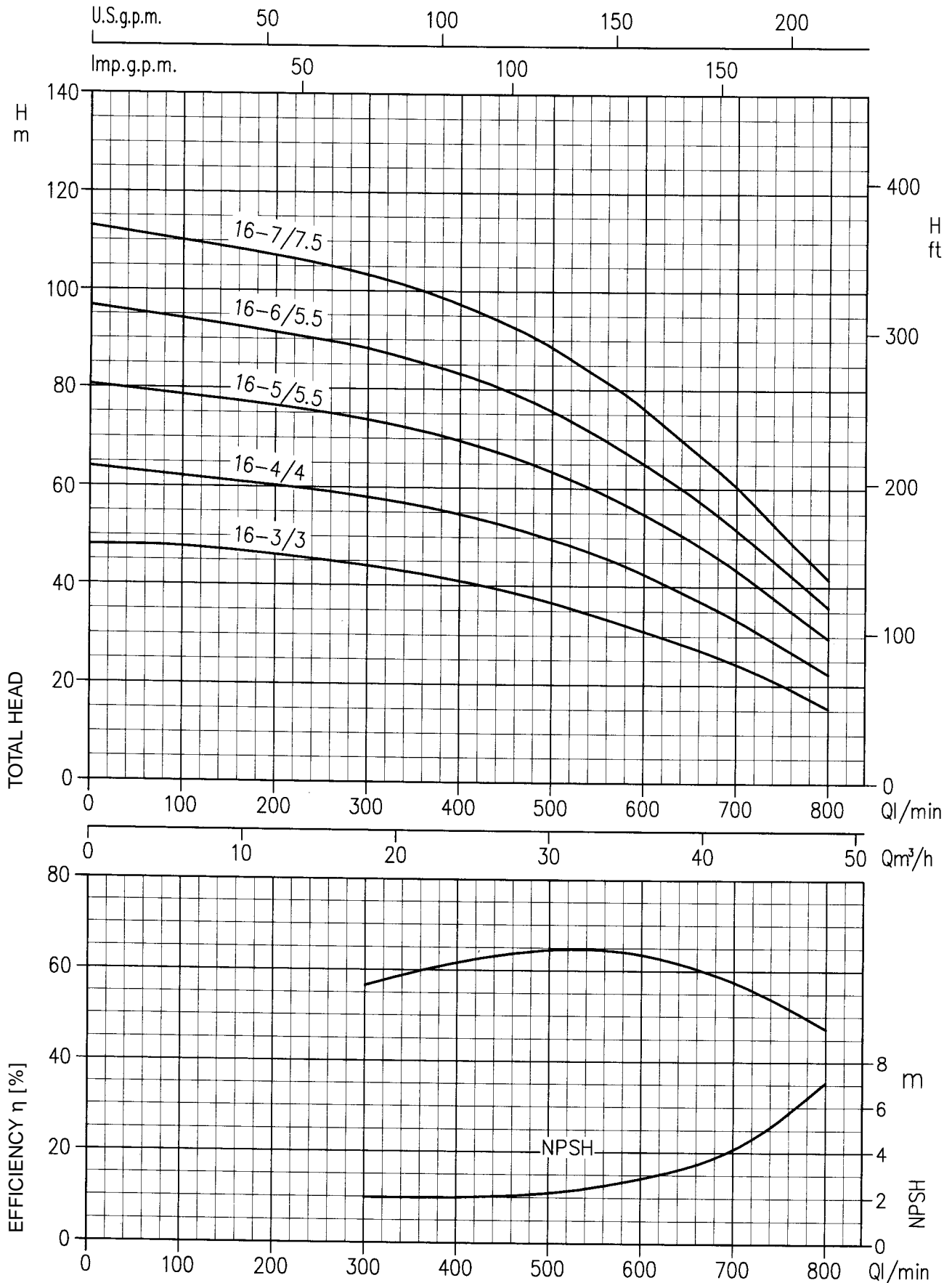

PERFORMANCE CURVES 2GP EVM(G) 30 (according to ISO 9906 grade 2)

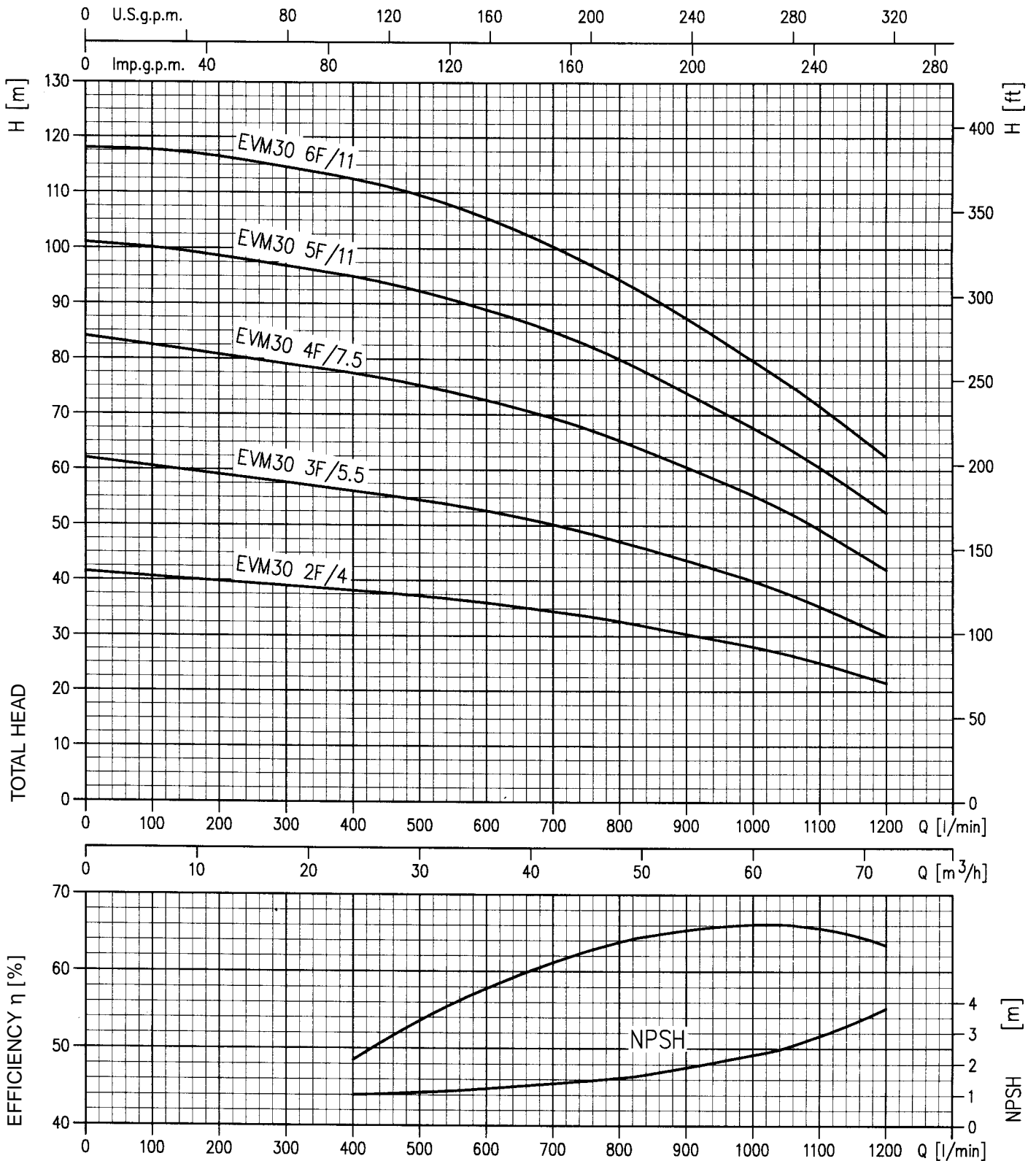

PERFORMANCE CURVES 2GP EVM(G) 60 (according to ISO 9906 grade 2)

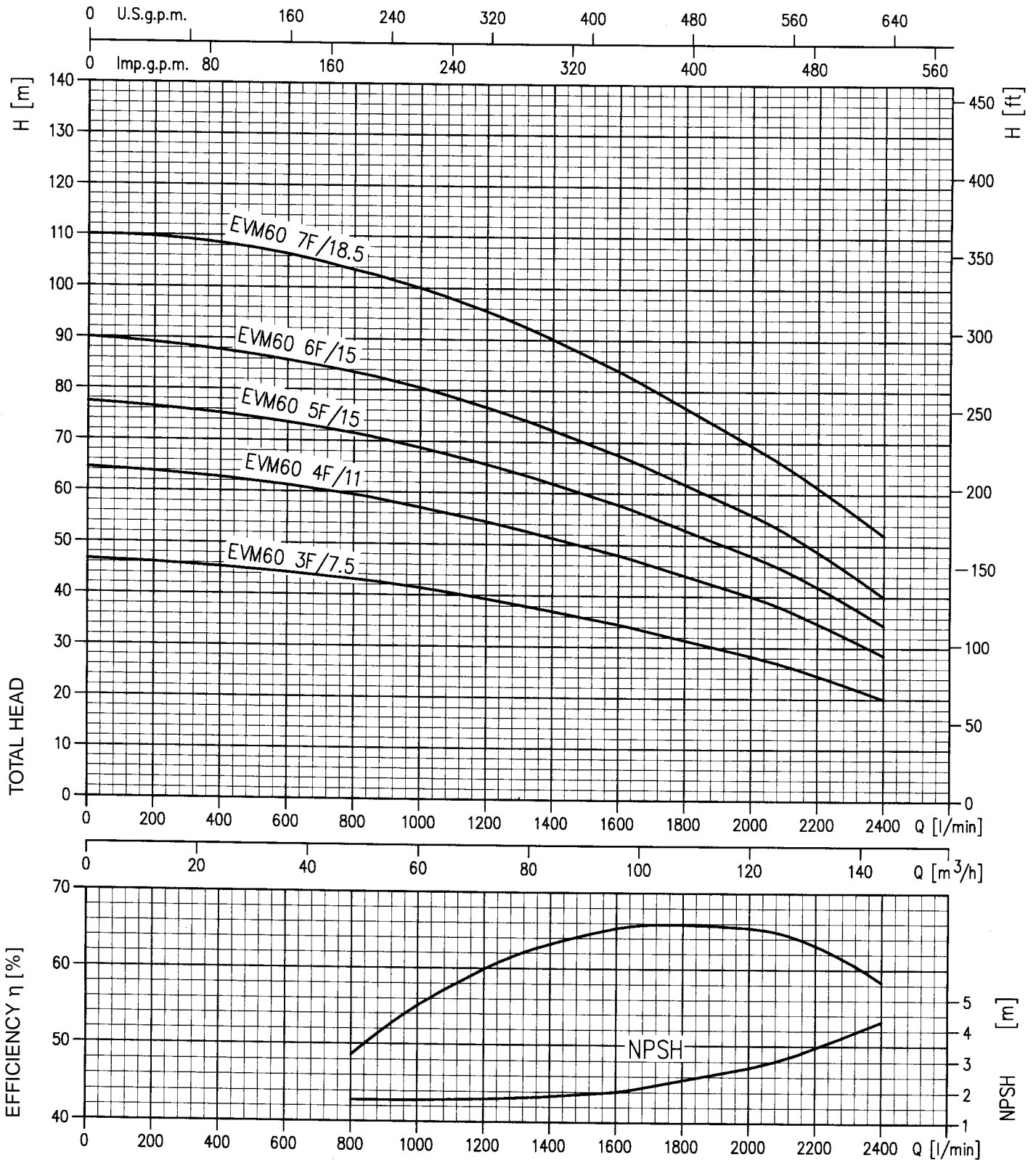

PERFORMANCE TABLE OF THE TWO PUMPS WORKING TOGETHER

Pump type			Absorbed current (A)		l/min m³/h	Q=Capacity															
230 V Single phase	400 V Three phase	kW	230 V Single phase	400 V Three phase		0	40	80	120	160	200	240	300	350	400	450	500	600	700	800	
							0	2,4	4,8	7,2	9,6	12	14,4	18	21	24	27	30	36	42	48
						H = Total head [m]															
EVM2 4N/0,55M	EVM2 4N/0,55	0,55 + 0,55	7,6	2,7	39,9	33,9	26,0	15,2													
EVM2 5N/0,55M	EVM2 5N/0,55	0,55 + 0,55	7,6	2,7	49,4	42,0	32,5	18,8													
EVM2 6N/0,75M	EVM2 6N/0,75	0,75 + 0,75	10,6	3,2	59,3	50,5	38,0	22,5													
EVM2 7N/0,75M	EVM2 7N/0,75	0,75 + 0,75	10,6	3,2	69,9	58,8	44,3	26,1													
EVM2 9N/1,1M	EVM2 9N/1,1	1,1 + 1,1	13	4,6	88,9	75,7	58,1	33,8													
EVM2 11N/1,1M	EVM2 11N/1,1	1,1 + 1,1	13	4,6	108,0	91,1	68,7	39,5													
EVM4 5N/1,1M	EVM4 5N/1,1	1,1 + 1,1	13	4,6	49,5		44,1	40,6	35,0	28,0	19,8										
EVM4 6N/1,1M	EVM4 6N/1,1	1,1 + 1,1	13	4,6	60,0		53,2	48,2	42,0	33,8	24,0										
EVM4 7N/1,5M	EVM4 7N/1,5	1,5 + 1,5	19	6,6	69,0		61,8	56,5	49,0	39,8	27,7										
EVM4 8N/1,5M	EVM4 8N/1,5	1,5 + 1,5	19	6,6	80,0		71,6	65,8	57,1	46,5	33,0										
	EVM4 10N/2,2	2,2 + 2,2		8,8	99,0		88,2	81,0	70,6	56,2	39,6										
	EVM4 11N/2,2	2,2 + 2,2		8,8	110,0		98,0	90,2	78,6	63,8	45,0										
	EVM4 12N/2,2	2,2 + 2,2		8,8	119,0		106,0	97,4	84,0	67,5	47,5										
EVM8 4N/1,5M	EVM8 4N/1,5	1,5 + 1,5		6,6	44,5				42,2	41,8	40,0	36,1	31,5	27,7	22,6						
	EVM8 5N/2,2	2,2 + 2,2		8,8	55,5				53,0	51,8	49,1	44,3	40,0	34,0	28,3						
	EVM8 6N/2,2	2,2 + 2,2		8,8	67,0				64,2	62,0	59,0	53,6	47,0	40,9	33,8						
	EVM8 8N/3	3 + 3		12,6	89				85,0	83,2	80,2	72,5	64,8	55,0	45,8						
	EVM8 10N/4	4 + 4		16,4	111				106,0	103,2	98,4	87,8	79,8	67,5	56,5						
	EVM8 11N/4	4 + 4		16,4	122				116,2	113,2	108,0	97,8	88,0	74,5	61,4						
	EVM16 3F/3	3 + 3		12,6	48							43,6	42,0	40,0	38,1	36,0	30,7	23,8	15,4		
	EVM16 4F/4	4 + 4		16,4	64							58,2	56,4	54,4	52,0	49,7	42,3	33,4	22,3		
	EVM16 5F/5,5	5,5 + 5,5		23	81							73,8	71,5	69,0	67,1	63,7	54,9	43,6	29,5		
	EVM16 6F/5,5	5,5 + 5,5		23	97							88,3	85,3	82,2	79,8	75,8	65,0	52,3	35,8		
	EVM16 7F/7,5	7,5 + 7,5		30,6	113							103,3	99,5	96,0	92,5	88,2	76,5	60,0	41,3		

Pump type			l/min m³/h	Q=Capacity															
400 V Three phase	kW	Abs. curr. (A) 400 V Three phase		0	200	300	400	500	600	666	800	900	1000	1100	1200	1400	1600	2000	2400
						0	12	18	24	30	36	40	48	54	60	66	72	84	96
				H=Total head [m]															
EVM(G) 30 2F/4	4 + 4	16,4	41,5	39,8	39	38,2	37,6	36,0	34,8	32,7	30,4	28,1	25	21,5					
EVM(G) 30 3F/5,5	5,5 + 5,5	23	62	59,1	58	56,2	54,0	52,5	50,5	47,2	44,0	40	35,5	30					
EVM(G) 30 4F/7,5	7,5 + 7,5	30,6	84	80,8	79,8	77,4	75,0	72,6	70,0	65,6	61,0	55,5	49	42					
EVM(G) 30 5F/11	11 + 11	40,8	101	98,7	97,7	95,0	92,0	89,0	86,0	80,1	75,0	67,7	60	52,3					
EVM(G) 30 6F/11	11 + 11	40,8	118	116,5	115,0	112,6	109,8	105,4	102,5	94,6	87,0	79,8	71,5	62,5					
EVM(G) 60 3F/7,5	7,5 + 7,5	30,6	46,6							43,0	42	41,5	40,5	39,3	37	34,5	28,3	19,5	
EVM(G) 60 4F/11	11 + 11	40,8	64,5							59,5	58	57	56	54,4	52	48	40	38,5	
EVM(G) 60 5F/15	15 + 15	55,2	77,3							71,5	70	68,5	67	65,6	62,3	57,8	48	34,3	
EVM(G) 60 6F/15	15 + 15	55,2	90							83,5	82	80	78	76,7	73	67,5	56	40	
EVM(G) 60 7F/18,5	18,5 + 18,5	64	110							103,5	102	100	97,5	95,5	90	84	69,5	52	

DIMENSIONAL DRAWINGS 2GP EVM(G)

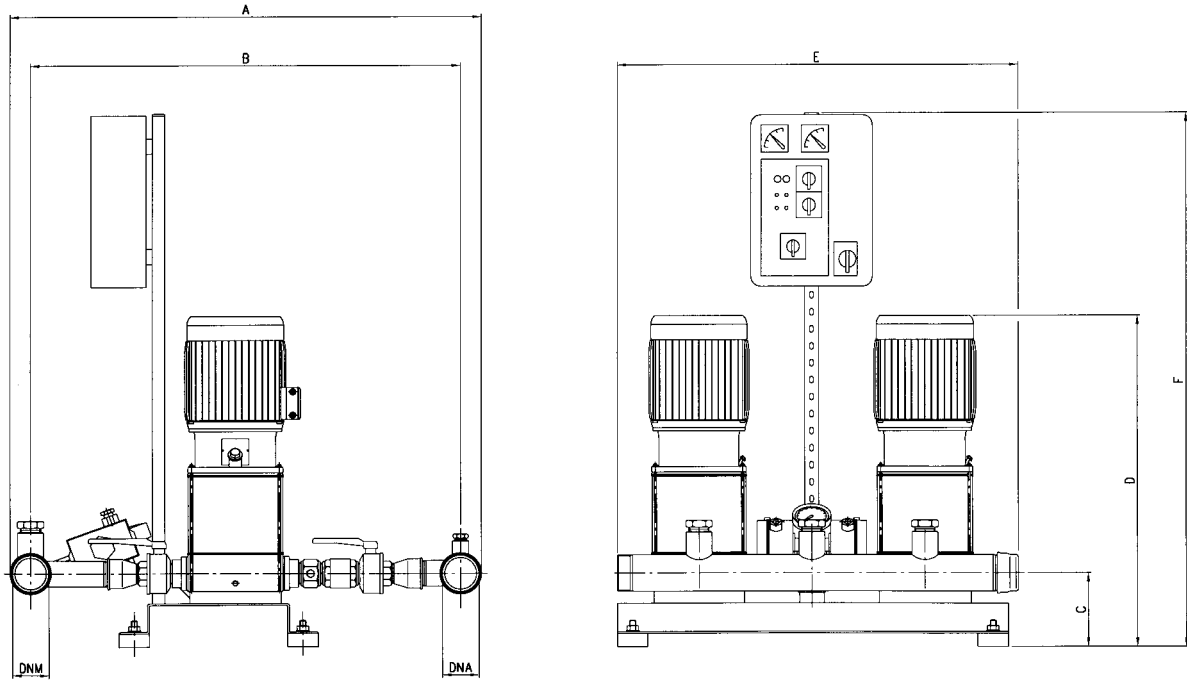

DIMENSIONAL TABLE

Model	Dimensions (mm)							
	A	B	C	D	E	F	DNA	DNM
2GP EVM2 4N/0,55	660	591	125	528	640	880	2"	2"
2GP EVM2 5N/0,55	660	591	125	543	640	880	2"	2"
2GP EVM2 6N/0,75	660	591	125	610	640	880	2"	2"
2GP EVM2 7N/0,75	660	591	125	631	640	880	2"	2"
2GP EVM2 9N/1,1	660	591	125	673	640	880	2"	2"
2GP EVM2 11N/1,1	660	591	125	715	640	880	2"	2"
2GP EVM4 5N/1,1	686	617	125	623	640	880	2 ¹ / ₂ "	2 ¹ / ₂ "
2GP EVM4 6N/1,1	686	617	125	651	640	880	2 ¹ / ₂ "	2 ¹ / ₂ "
2GP EVM4 7N/1,5	686	617	125	693	640	880	2 ¹ / ₂ "	2 ¹ / ₂ "
2GP EVM4 8N/1,5	686	617	125	721	640	880	2 ¹ / ₂ "	2 ¹ / ₂ "
2GP EVM4 10N/2,2	686	617	125	804	640	880	2 ¹ / ₂ "	2 ¹ / ₂ "
2GP EVM4 11N/2,2	686	617	125	832	640	880	2 ¹ / ₂ "	2 ¹ / ₂ "
2GP EVM4 12N/2,2	686	617	125	915	1030	1000	2 ¹ / ₂ "	2 ¹ / ₂ "
2GP EVM8 4N/1,5	822	722	155	690	1030	1000	80	80
2GP EVM8 5N/2,2	822	722	155	747	1030	1000	80	80
2GP EVM8 6N/2,2	822	722	155	777	1030	1000	80	80
2GP EVM8 8N/3,0	822	722	155	892	1030	1000	80	80
2GP EVM8 10N/3,0	822	722	155	982	1030	1000	80	80
2GP EVM8 11N/4,0	822	722	155	1012	1030	1000	80	80
2GP EVM16 3F/3,0	1134	914	165	782	1030	1000	100	100
2GP EVM16 4F/4,0	1134	914	165	822	1030	1000	100	100
2GP EVM16 5F/5,5	1134	914	165	942	1030	1000	100	100
2GP EVM16 6F/5,5	1134	914	165	982	1030	1000	100	100
2GP EVM16 7F/7,5	1134	914	165	1022	1030	1000	100	100
2GP EVM(G) 30 2F/4	1650	1500	205	903	1200	1800	150	150
2GP EVM(G) 30 3F/5.5	1650	1500	205	1038	1200	1800	150	150
2GP EVM(G) 30 4F/7.5	1650	1500	205	1086	1200	1800	150	150
2GP EVM(G) 30 5F/11	1650	1500	205	1290	1200	1800	150	150
2GP EVM(G) 30 6F/11	1650	1500	205	1338	1200	1800	150	150
2GP EVM(G) 60 3F/7.5	1890	1690	240	1163	1200	1800	200	200
2GP EVM(G) 60 4F/11	1890	1690	240	1390	1200	1800	200	200
2GP EVM(G) 60 5F/15	1890	1690	240	1462	1200	1800	200	200
2GP EVM(G) 60 6F/15	1890	1690	240	1534	1200	1800	200	200
2GP EVM(G) 60 7F/18.5	1890	1690	240	1606	1200	1800	200	200

PRESSURE BOOSTER SETS WITH 2 "3M" SERIES HORIZONTAL SINGLE-BLOCK PUMPS DERIVED FROM EN 733 (ex DIN 24255), WITH STEEL STAINLESS HYDRAULICS



TECHNICAL CHARACTERISTICS

The set base and manifolds are of galvanized steel. The delivery manifold can accept a further 2 vertical-type diaphragm tanks. 2 pressure switches, the control panel and a pressure gauge are all positioned on the manifold. Each pump has a suction gate valve, non-return valve and delivery gate valve. Each pump can also be connected to an air feeder.

CE marked control panel

- Components IMQ and VDE marked.
- Very low voltage auxiliary circuit.
- Motor starting and stopping is controlled by 2 pressure switches.
- Can be connected to floats or low pressure switches to stop operation if there is no supply water.
- Equipped with a device that alternates the lead pump at each start.
- Supply:
 - three phase 400 V, 50 Hz
- Starting:
 - direct for powers up to 7,5 kW
 - star/triangle for powers above 7,5 kW
- Power circuit protection fuses
- Auxiliary circuit protection fuses
- IP 55 protection
- Door interlocked isolator
- Aut. - 0 - man. switches for each pump
- Thermal protection reset
- Pilot LED:
 - mains power
 - pump running
 - level alarm
 - pump being protected (only for three phase version)
- Special version of panels can be used upon request

WORKING PRINCIPLE

If there is a water demand while the pumps are stopped, the pressure in the system drops. As a consequence the highest-set pressure switch contact closes, and this causes the first pump to start. If the required flow is greater than the capacity of one pump, the pressure continues to drop until the second pressure switch contact closes and the second pump starts. Stopping or reducing the outgoing flow raises the system pressure, which in turn causes the pressure switch contact to open and allows the pumps to stop in turn. Alternating the starting order of the two pumps reduces the number of hourly starts of the lead pump and balances their running times. Connecting a low level float in the supply tank or a low pressure switch in the system, wired through to the control panel will protect against the most frequent cause of pump failure: dry running.

PERFORMANCE CURVES 2GP 3M 32 (according to ISO 9906 grade 2)

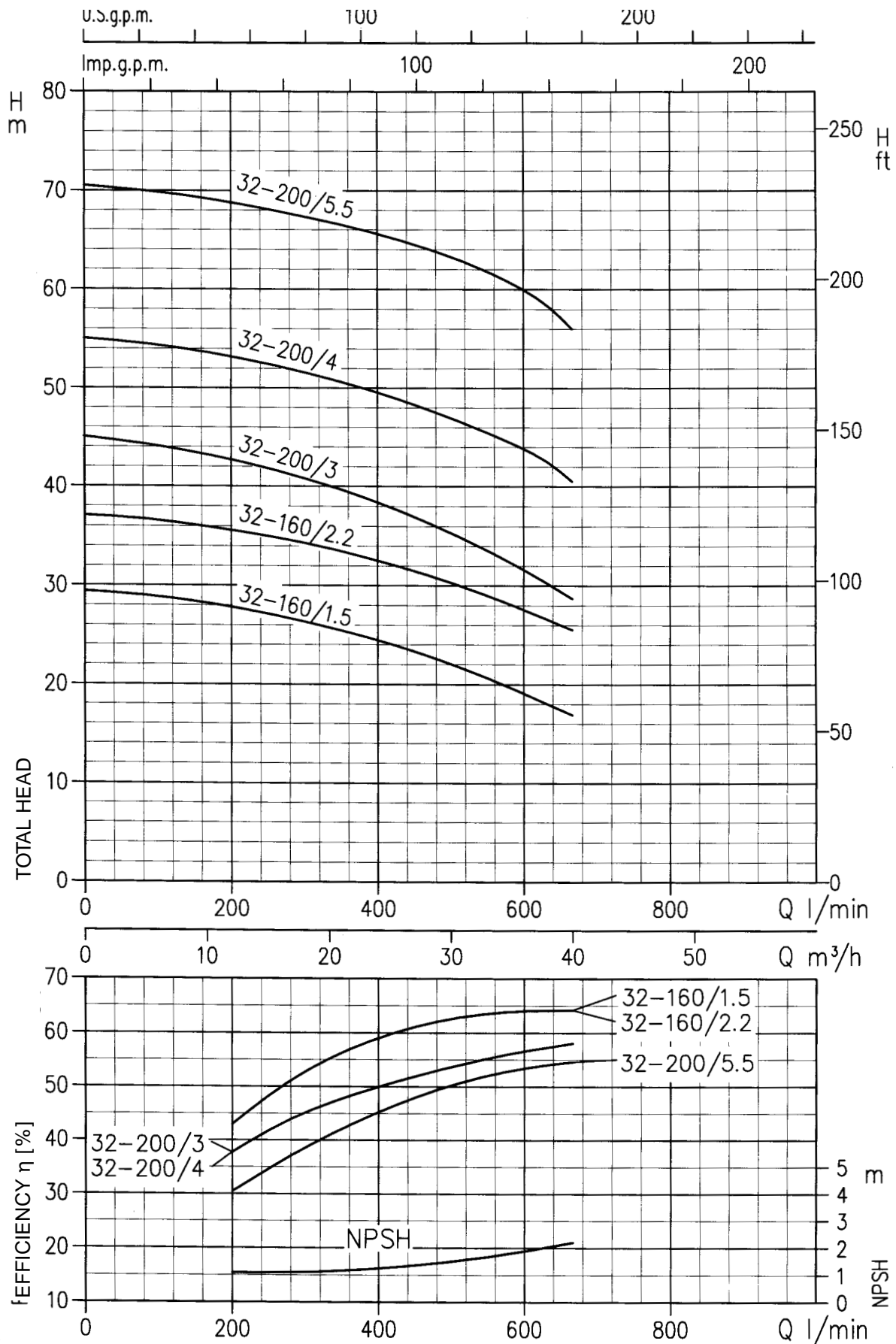

PERFORMANCE CURVES 2GP 3M 40 (according to ISO 9906 grade 2)

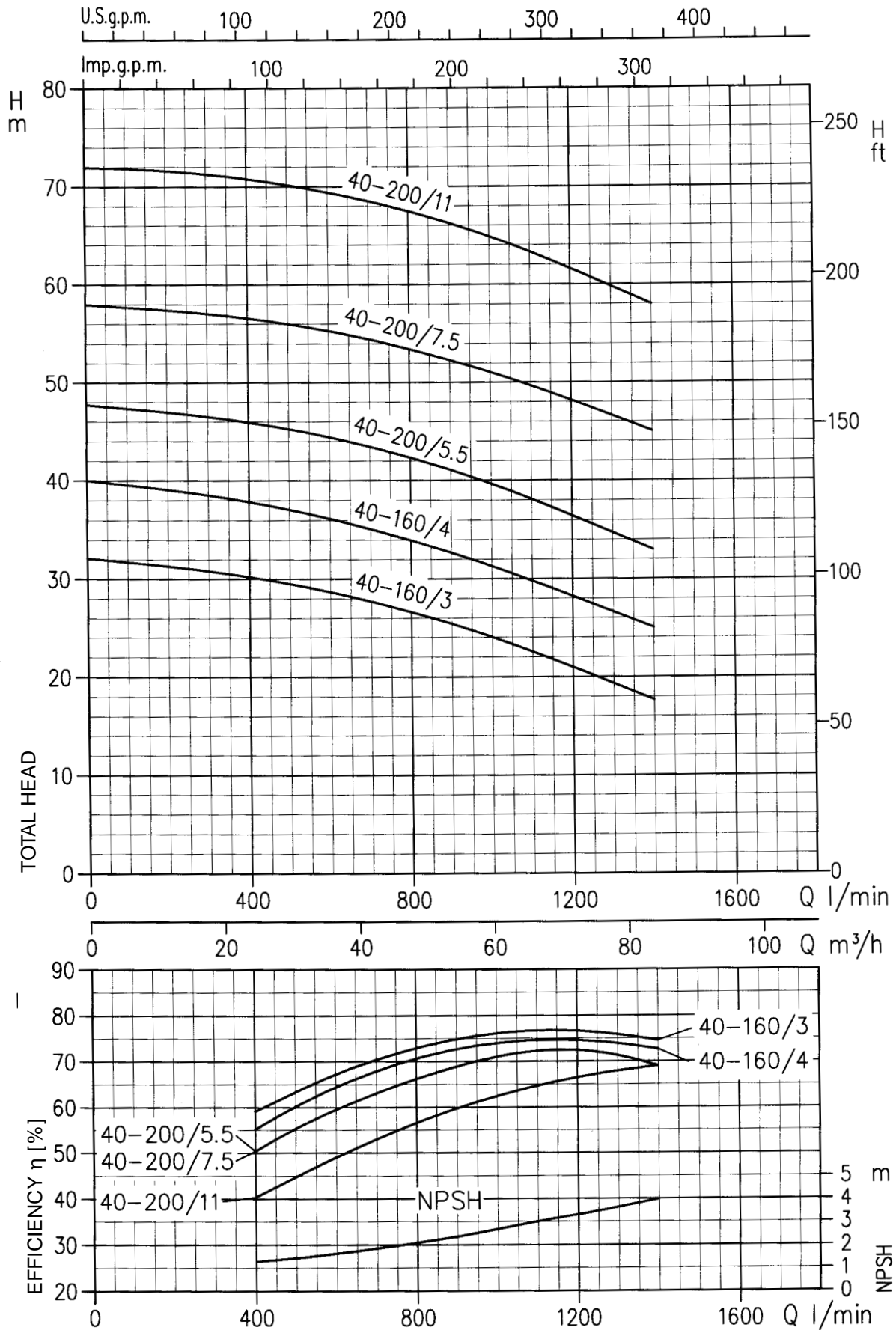

PERFORMANCE CURVES 2GP 3M 50 (according to ISO 9906 grade 2)

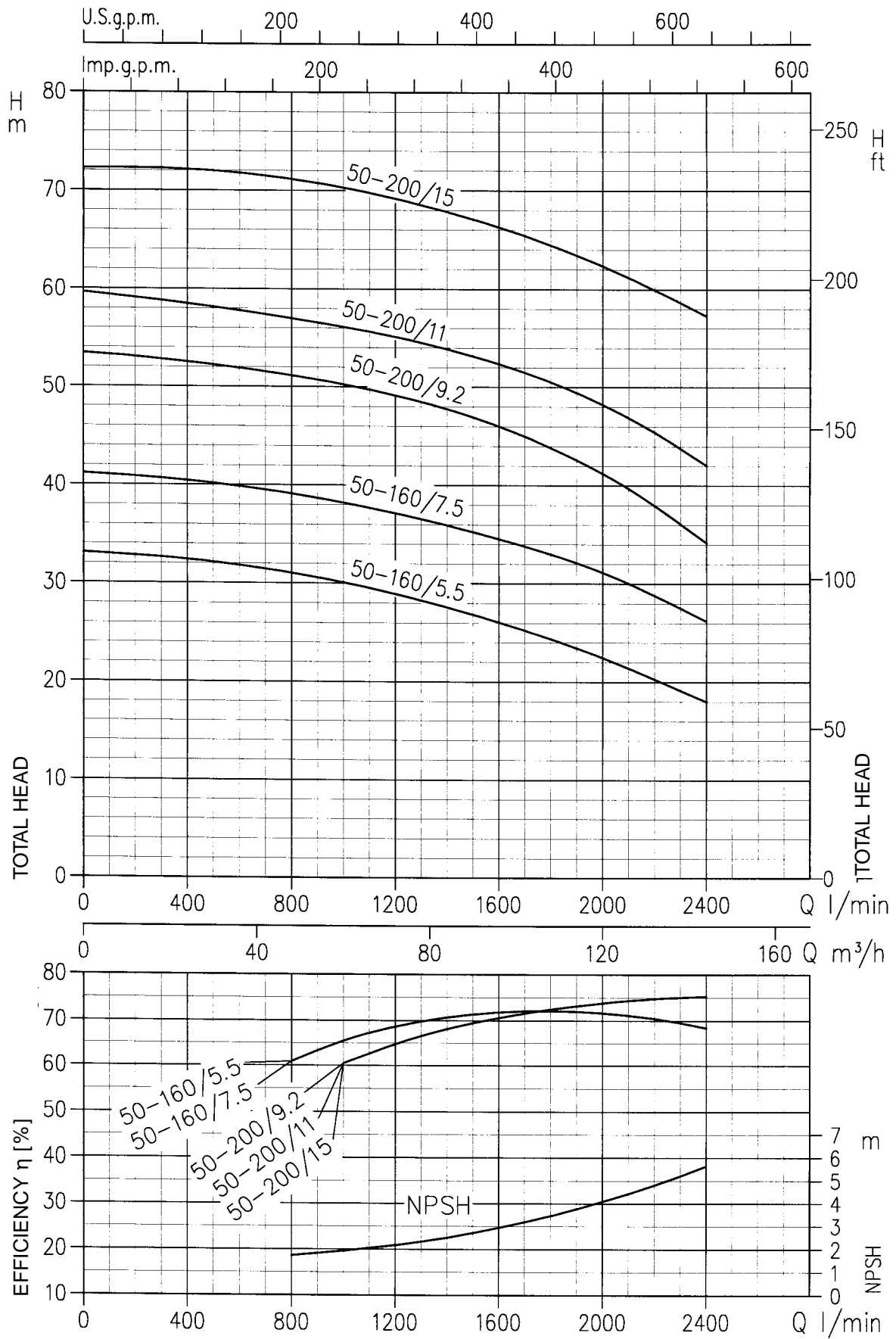

PERFORMANCE TABLE OF THE TWO PUMPS WORKING TOGETHER

Pump type 400 V Three phase	kW	Absor. curr. (A)	Q=Capacity																		
			l/min m³/h	0	200	300	400	500	560	600	666	800	900	1000	1100	1200	1400	1600	2000	2200	2400
				0	12	18	24	30	33,6	36	40	48	54	60	66	72	84	96	120	132	144
			H = Total head [m]																		
3M 32-160/1,5	1,5 + 1,5	6,8	29,5	28	26,5	24,5	22	20,5	19	17											
3M 32-160/2,2	2,2 + 2,2	9,6	37	35,5	34,5	32,5	30,5	29	27,5	25,5											
3M 32-200/3	3 + 3	13,6	45	42,5	41	38,5	35	33,5	31,5	29											
3M 32-200/4	4 + 4	18	55	53	51,5	49,5	47	45,5	43,5	40,5											
3M 32-200/5,5	5,5 + 5,5	23,6	70,5	69	67,6	65,5	63	61,8	60	56											
3M 40-160/3	3 + 3	13,6	32			30	29	28,8	28,5	27,3	26,2	25,4	24	22,5	21	17,5					
3M 40-160/4	4 + 4	18,4	40			37,5	37	36,6	36	35	34	33	31,3	30	28,5	25					
3M 40-200/5,5	5,5 + 5,5	22,2	47,5			46	45	44,6	44	43,5	42	41	40	38,5	37	33					
3M 40-200/7,5	7,5 + 7,5	30,2	58			56,5	56	55,7	55,3	55	53,5	52,5	51,2	49,8	48,5	45					
3M 40-200/11	11 + 11	40	72			71	70	69,7	69,3	68,8	67,5	66,2	65	63,5	62	58					
3M 50-160/5,5	5,5 + 5,5	23	33								31	30,5	30	29,5	29	27,6	26	22,5	20	18	
3M 50-160/7,5	7,5 + 7,5	31	41								39	38,5	38	37,5	37	36	34,5	31	29	26	
3M 50-200/9,2	9,2 + 9,2	34,8	53									50	49,5	49	47,5	46	41	38	34		
3M 50-200/11	11 + 11	44	59,5									56	55,5	55	53,8	52	48	45,4	42		
3M 50-200/15	15 + 15	62,6	73									70	69,5	69	68	66	62	60	57		

DIMENSIONAL DRAWINGS 2GP-3M

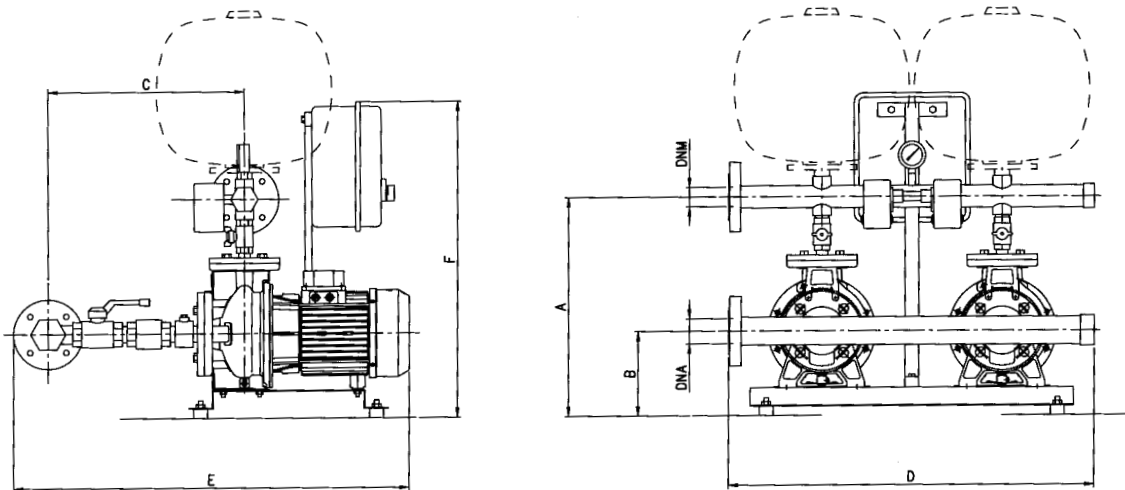

DIMENSIONAL TABLE

Model	Dimensions (mm)										Weight Kg
	A	B	C	D	E	DNA	DNM	F	G	H	
2GP 3M 32-160/1,5	800	900	900	232	600	3"	2 ¹ / ₂ "	1000	1100	1100	139
2GP 3M 32-160/2,2	800	900	900	232	600	3"	2 ¹ / ₂ "	1000	1100	1100	143
2GP 3M 32-200/3,0	800	900	900	260	630	3"	2 ¹ / ₂ "	1000	1100	1100	157
2GP 3M 32-200/4,0	800	900	900	240	630	3"	2 ¹ / ₂ "	1000	1100	1100	176
2GP 3M 32-200/5,5	800	900	900	240	630	3"	2 ¹ / ₂ "	1000	1100	1100	176
2GP 3M 40-160/3,0	900	1050	1000	232	600	4"	3"	1100	1250	1200	167
2GP 3M 40-160/4,0	900	1050	1000	232	600	4"	3"	1100	1250	1200	180
2GP 3M 40-200/5,5	900	1050	1000	260	630	4"	3"	1100	1250	1200	208
2GP 3M 40-200/7,5	900	1050	1000	260	630	4"	3"	1100	1250	1200	220
2GP 3M 40-200/11	900	1050	1000	260	630	4"	3"	1100	1250	1200	220
2GP 3M 50-160/5,5	900	1100	1200	260	740	6"	4"	1100	1300	1400	198
2GP 3M 50-160/7,5	900	1100	1200	260	740	6"	4"	1100	1300	1400	215
2GP 3M 50-200/9,2	900	1100	1200	260	740	6"	4"	1100	1300	1400	243
2GP 3M 50-200/11	900	1100	1200	260	740	6"	4"	1100	1300	1400	270
2GP 3M 50-200/15	900	1100	1200	260	740	6"	4"	1100	1300	1400	270

PRESSURE BOOSTER SETS WITH 2 "MD/MMD" SERIES HORIZONTAL SINGLE-BLOCK PUMPS DERIVED FROM EN 733 (ex DIN 24255) WITH CAST IRON HYDRAULICS



TECHNICAL CHARACTERISTICS

The set base and manifolds are of galvanized steel. The delivery manifold can accept a further 2 vertical-type diaphragm tanks. 2 pressure switches, the control panel and a pressure gauge are all positioned on the manifold. Each pump has a suction gate valve, non-return valve and delivery gate valve. Each pump can also be connected to an air feeder.

CE marked control panel

- Components IMQ and VDE marked.
- Very low voltage auxiliary circuit.
- Motor starting and stopping is controlled by 2 pressure switches.
- Can be connected to floats or low pressure switches to stop operation if there is no supply water.
- Equipped with a device that alternates the lead pump at each start.
- Supply:
 - three phase 400 V, 50 Hz
- Starting:
 - direct for powers up to 7,5 kW
 - star/triangle for powers above 7,5 kW
- Power circuit protection fuses
- Auxiliary circuit protection fuses
- IP 55 protection
- Door interlocked isolator
- Aut. - 0 - man. switches for each pump
- Thermal protection reset
- Pilot LED:
 - mains power
 - pump running
 - level alarm
 - pump being protected (only for three phase version)
- Special version of panels can be used upon request

WORKING PRINCIPLE

If there is a water demand while the pumps are stopped, the pressure in the system drops. As a consequence the highest-set pressure switch contact closes, and this causes the first pump to start. If the required flow is greater than the capacity of one pump, the pressure continues to drop until the second pressure switch contact closes and the second pump starts. Stopping or reducing the outgoing flow raises the system pressure, which in turn causes the pressure switch contact to open and allows the pumps to stop in turn. Alternating the starting order of the two pumps reduces the number of hourly starts of the lead pump and balances their running times. Connecting a low level float in the supply tank or a low pressure switch in the system, wired through to the control panel will protect against the most frequent cause of pump failure: dry running.

PERFORMANCE CURVES 2GP MD 32 (according to ISO 9906 grade 2)

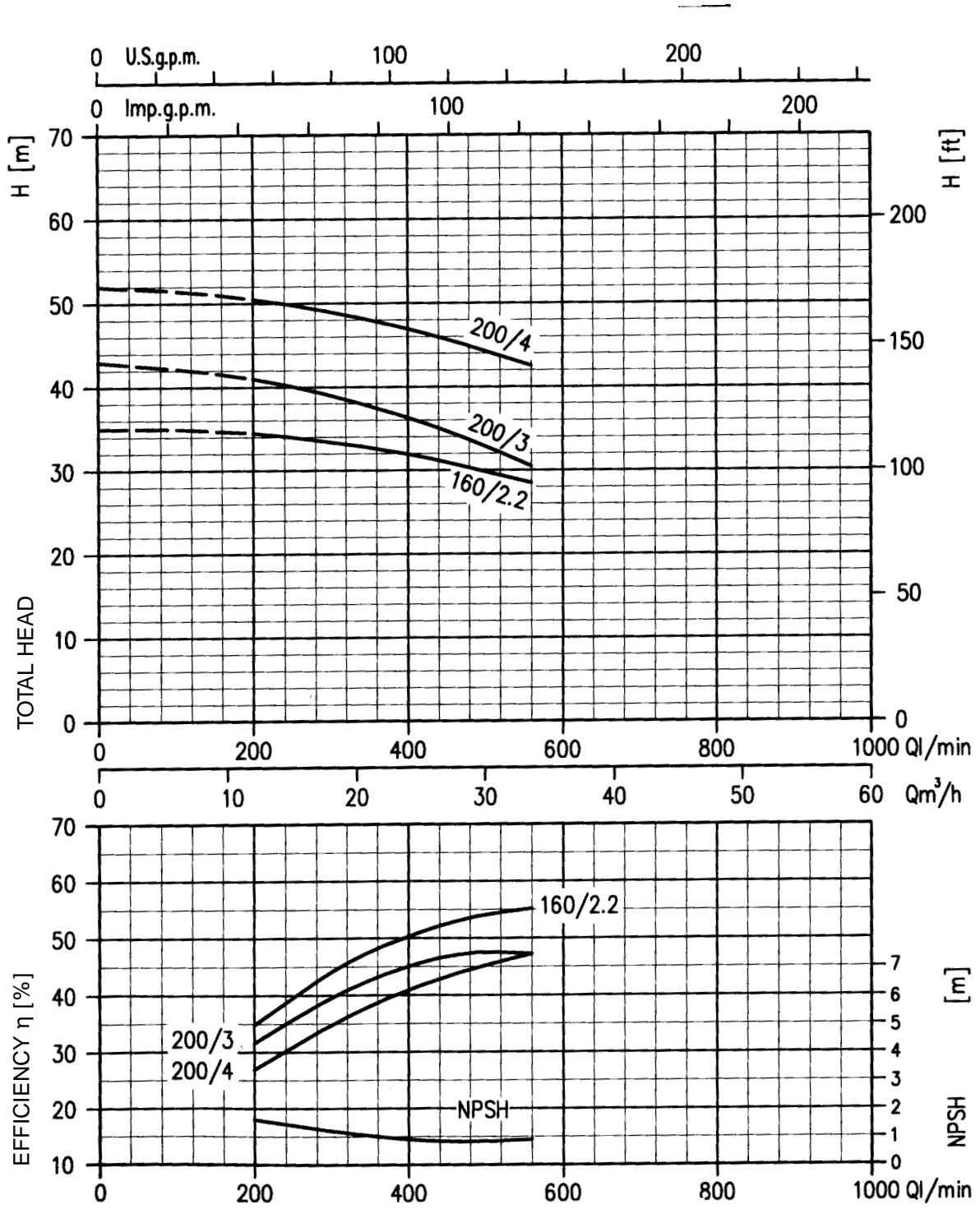

PERFORMANCE CURVES 2GP MMD 32 (according to ISO 9906 grade 2)

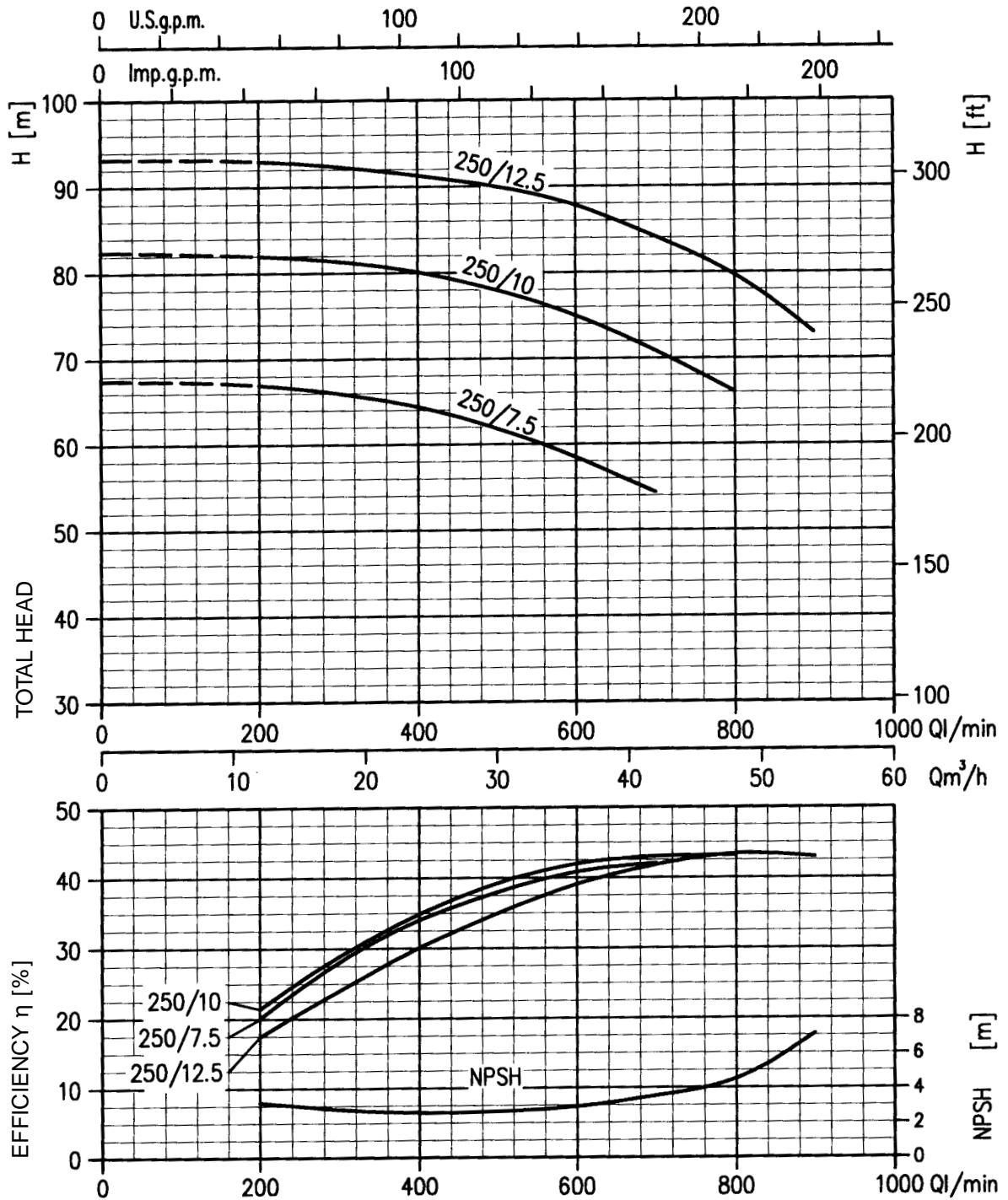

PERFORMANCE CURVES 2GP MD 40 (according to ISO 9906 grade 2)

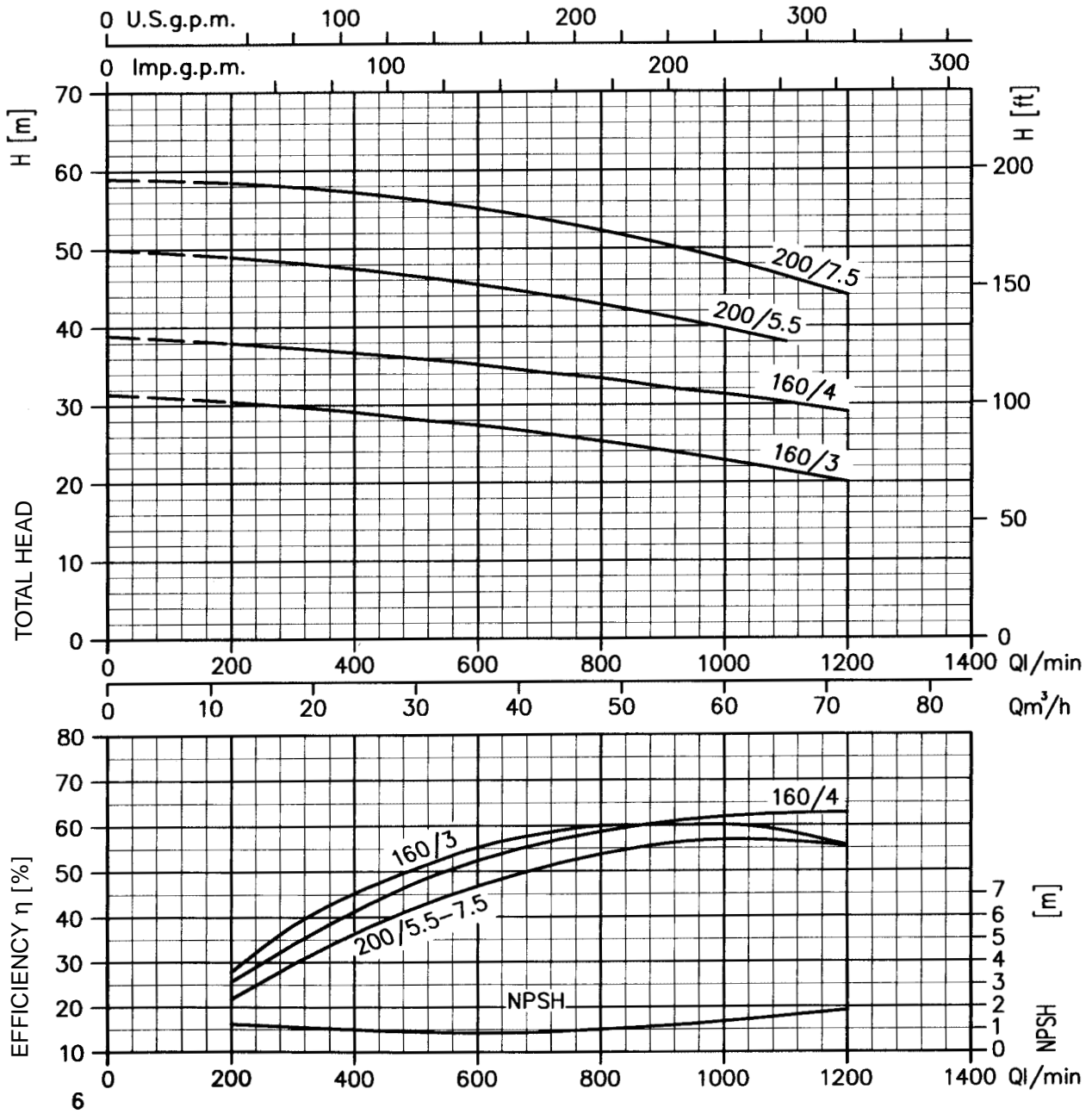

PERFORMANCE CURVES 2GP MMD 40 (according to ISO 9906 grade 2)

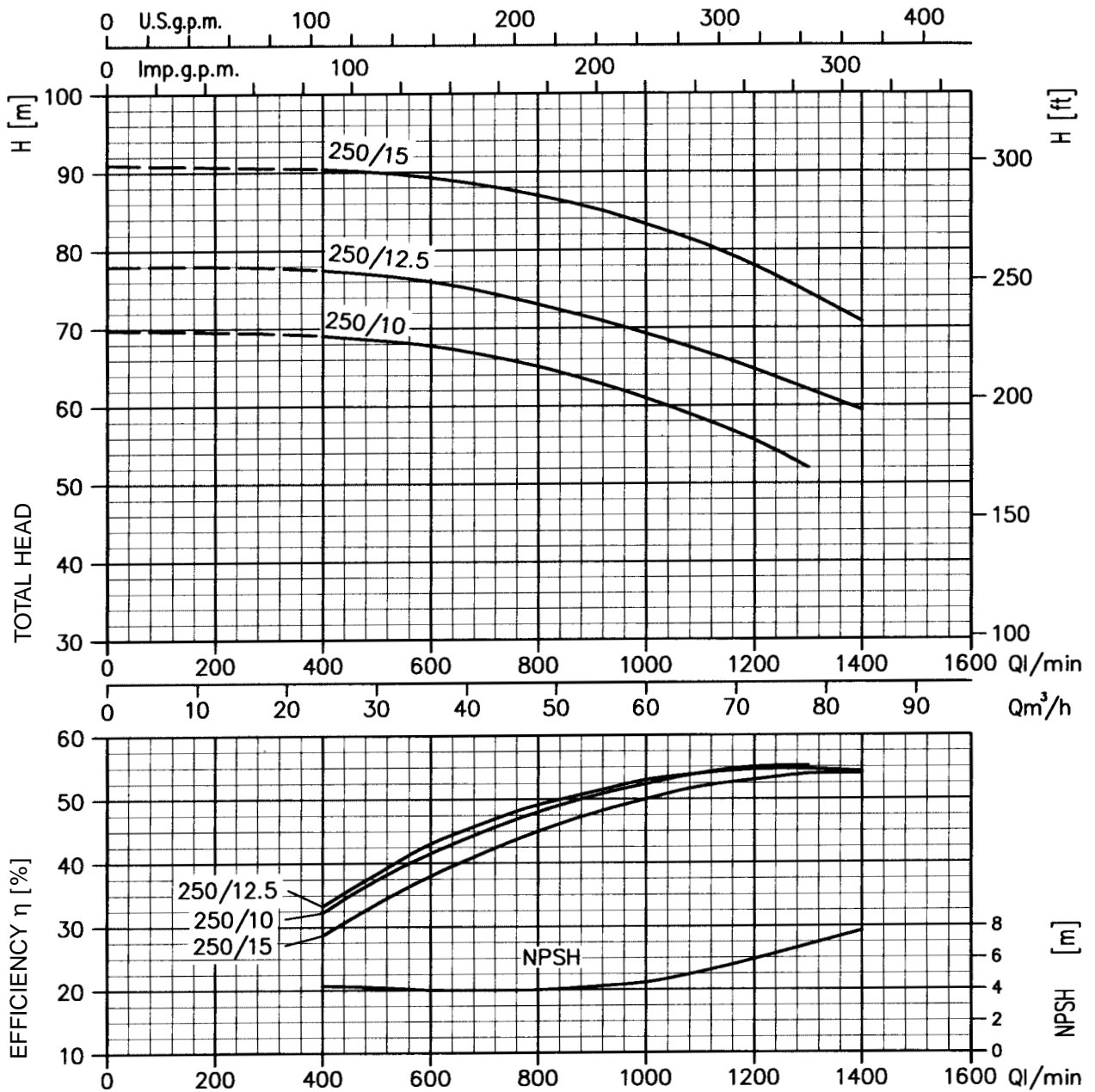

PERFORMANCE CURVES 2GP MD 50 (according to ISO 9906 grade 2)

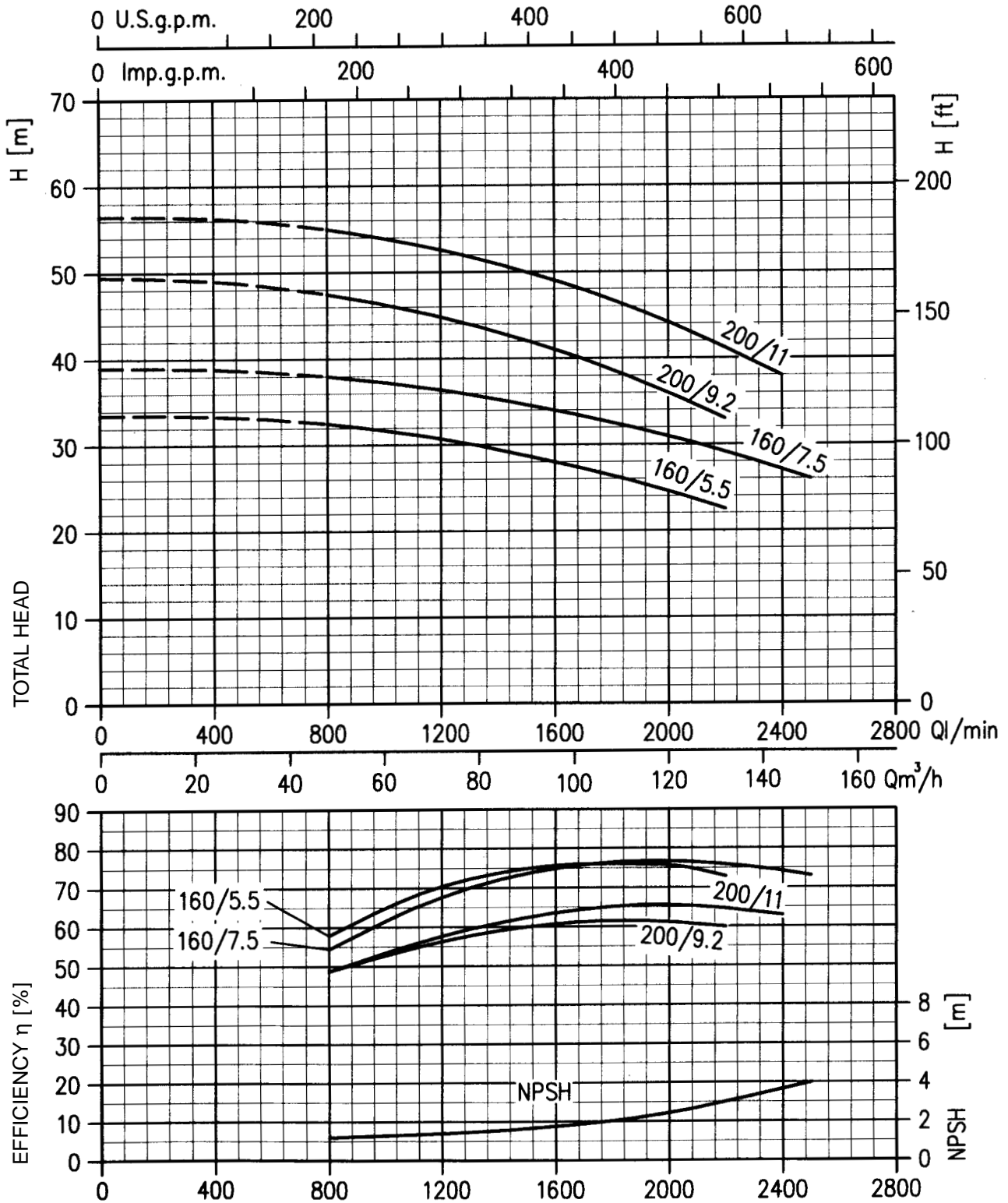

PERFORMANCE CURVES 2GP MMD 50 (according to ISO 9906 grade 2)

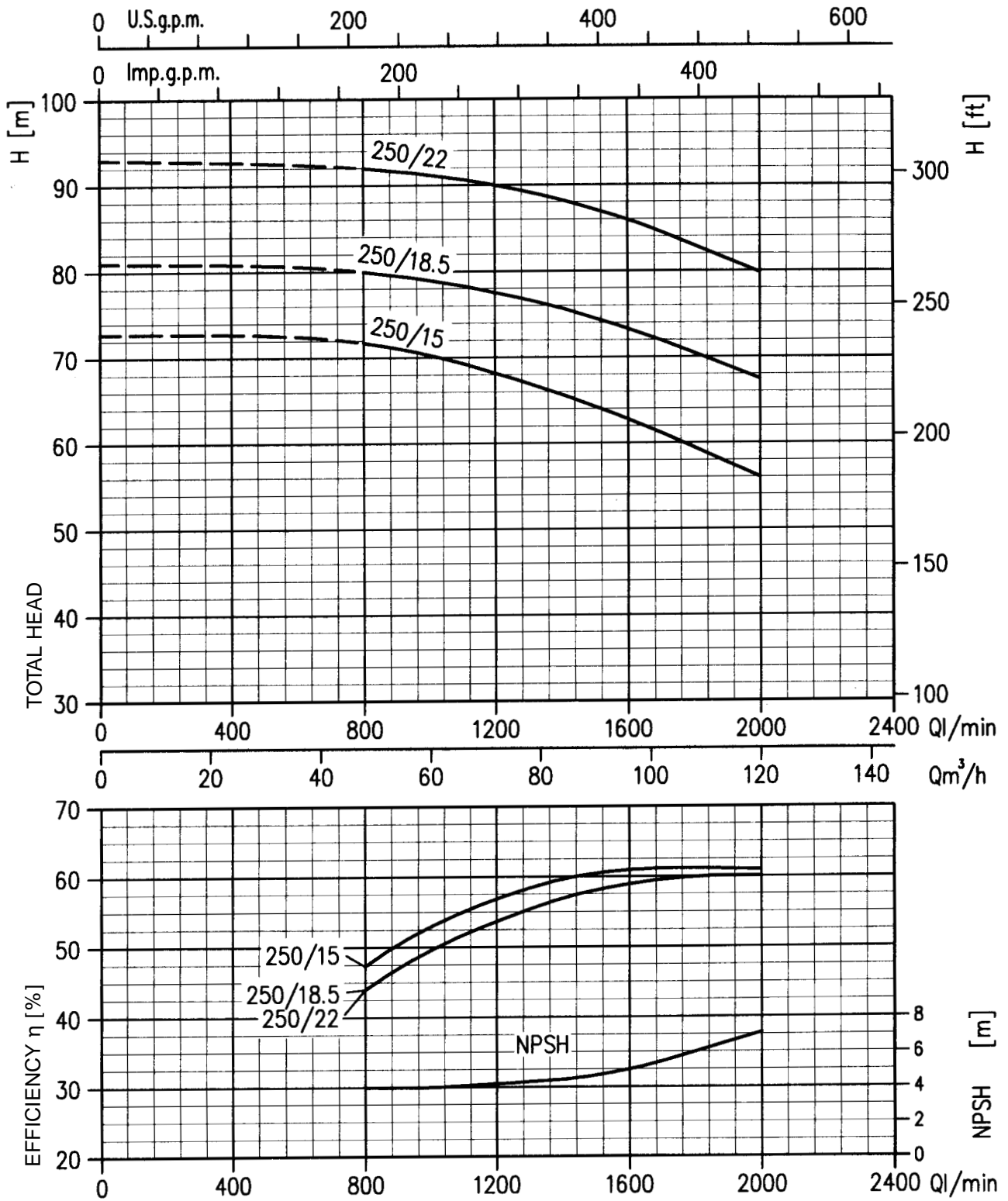

PERFORMANCE CURVES 2GP MD 65 (according to ISO 9906 grade 2)

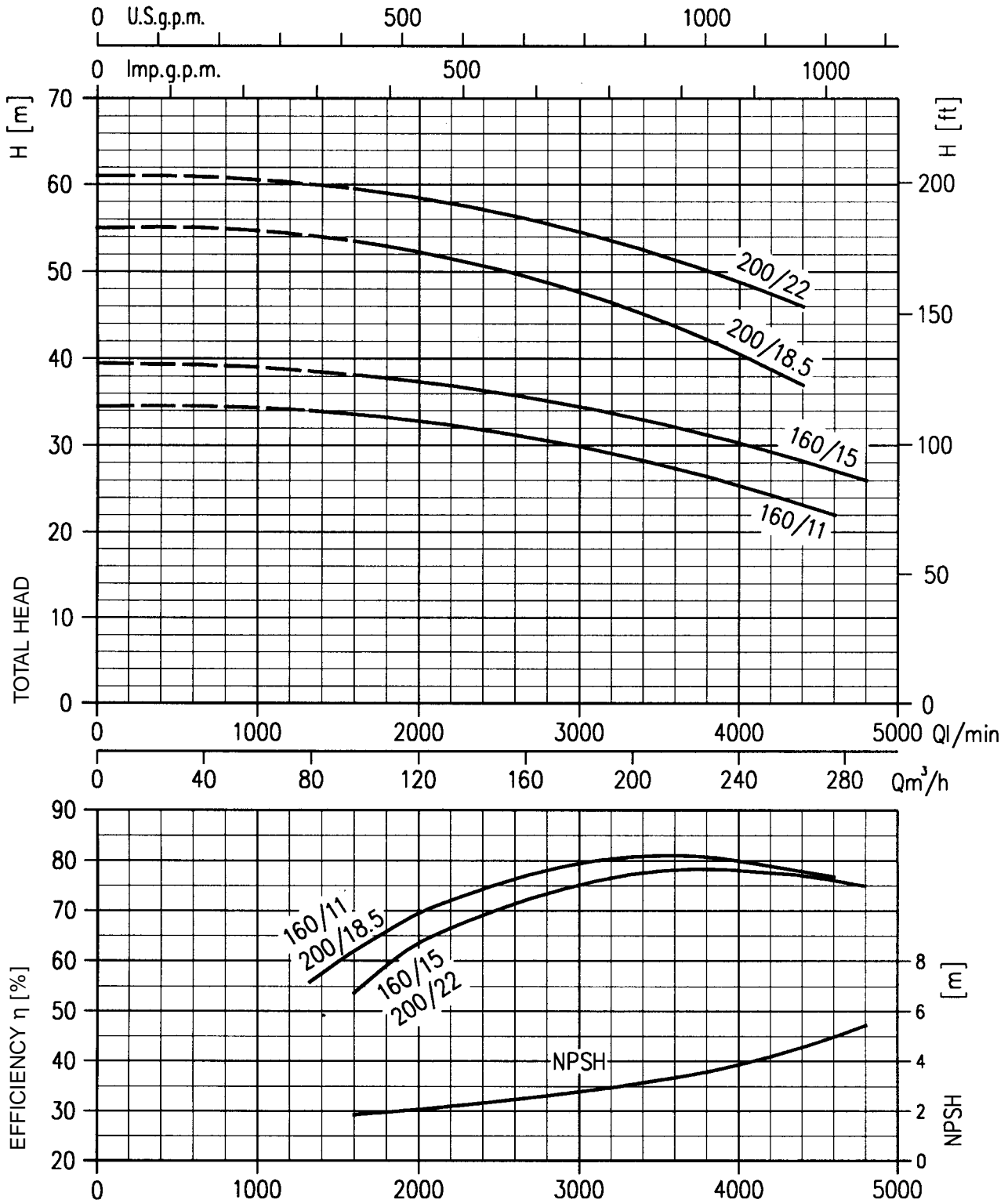

PERFORMANCE CURVES 2GP MMD 65 (according to ISO 9906 grade 2)

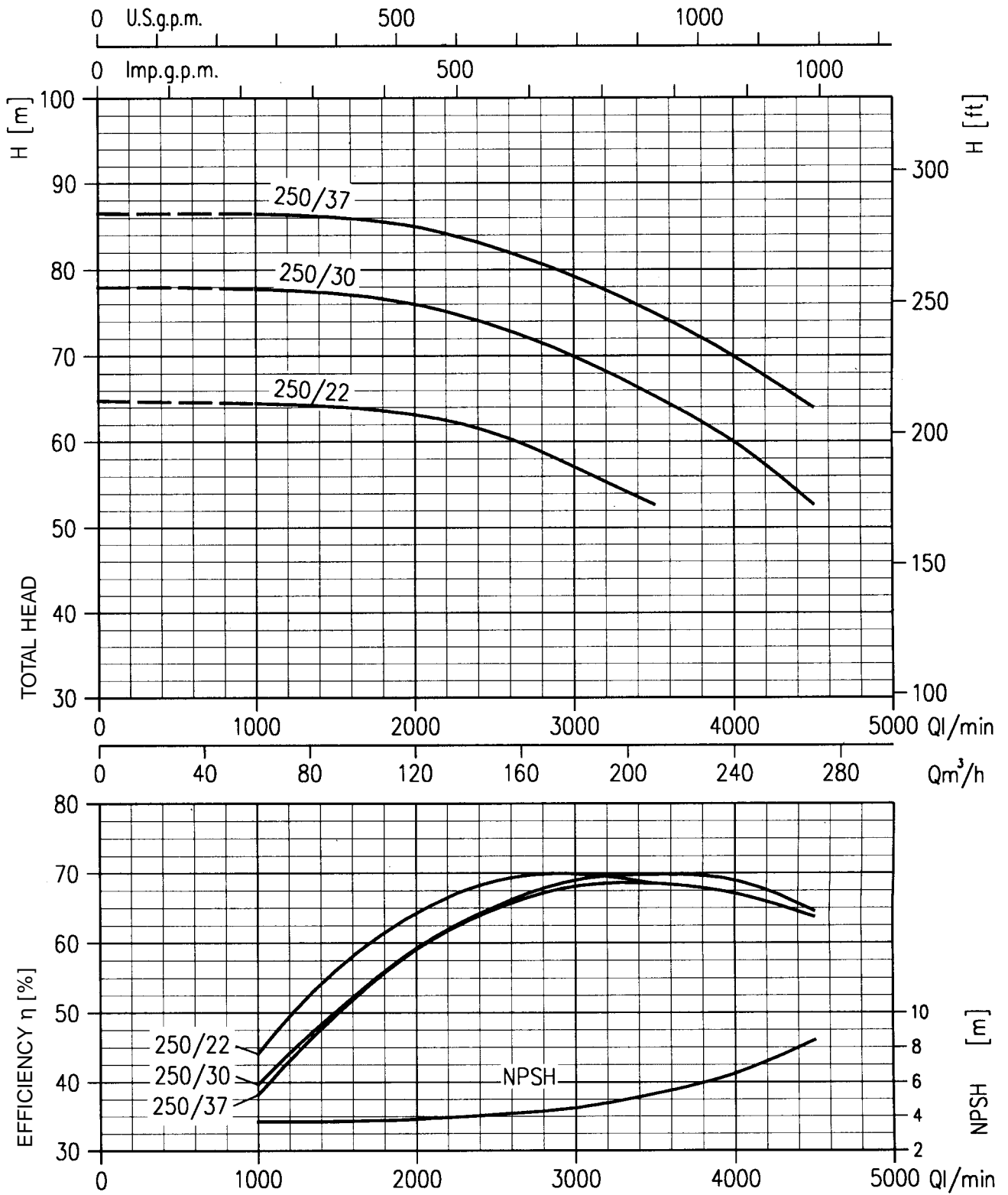

PERFORMANCE TABLE OF THE TWO PUMPS WORKING TOGETHER

Pump type	Absor. curr. (A)	kW	l/min m³/h	Q=Capacity																							
				0	200	300	400	500	560	600	666	800	900	1000	1100	1200	1400	1600	2000	2200	2400	2800	3400	3800	4400	4600	
400 V Three phase				H=Total head [m]																							
				0	12	18	24	30	33,6	36	40	48	54	60	66	72	84	96	120	132	144	168	204	228	264	276	
MD 32-160/1,5	1,5 + 1,5	6,8		29	27	26	23,9	21,9	20,5																		
MD 32-160/2,2	2,2 + 2,2	10		35	34,5	34	32	30	28,5																		
MD 32-200/3	3 + 3	13,8		43	41	39	36,3	32,9	30,5																		
MD 32-200/4	4 + 4	18,4		52	50,5	49	46,9	44,3	42,5																		
MMD 32-250/7,5	7,5 + 7,5	34,6		67,5	67	66	64	61,5	60	58	56																
MMD 32-250/10	10 + 10	45		82,4	82	81	80	78	76,5	75	73	66															
MMD 32-250/12,5	12,5 + 12,5	54		93,5	93	92	91	90	89	88	88,5	80															
MD 40-160/3	3 + 3	13,2		31,5	30,5	30	29,1	28,3	27,8	27,5	27	25,3	24	23	21,5	20											
MD 40-160/4	4 + 4	19,6		39	38	37	36,7	36	35,5	35	34,5	33,4	32	31,5	30,2	29											
MD 40-200/5,5	5,5 + 5,5	23		50	49	48	47,5	46,5	45,6	45,3	45	42,9	41,5	40	38												
MD 40-200/7,5	7,5 + 7,5	31		59	58,5	58	57,2	56,3	55,6	55	54	52,3	50	48,5	46,4	44											
MD 40-250/10	10 + 10	45		70				69	68,5	68	67	65	63	61	59	57											
MMD 40-250/12,5	12,5 + 12,5	54		78				77	76,5	76	75	73	71	69	67	65	60										
MMD 40-250/15	15 + 15	64		91				90	89,5	89	88,5	87	85	83	80,5	78	71										
MD 50-160/5,5	5,5 + 5,5	23,6		33,5								32,5	32	31,8	31,2	30,7	29,7	28,1	24,6	22,5							
MD 50-160/7,5	7,5 + 7,5	30		39								38	37,8	37,4	36,9	36,4	35,5	34,1	31	29,1	27,1						
MD 50-200/9,2	9,2 + 9,2	38		49,5								47,5	47	46,3	45,6	44,8	43	41,1	36	33							
MD 50-200/11	11 + 11	44		56,5								55	54,2	53,8	53,3	52,6	51	49	44,2	41,3	38						
MMD 50-250/15	15 + 15	64		73								72	71	70	69	68	66	63	56								
MMD 50-250/18,5	18,5 + 18,5	76		81								80,5	80	79,5	78,5	77,5	75,5	73,5	67,5								
MMD 50-250/22	22 + 22	89		93								92	91,8	91,5	91	90	88	86	80								
MD 65-160/11	11 + 11	41,6		34,5													33,8	33,6	32,8	32,3	31,8	30,5	28	26,4	23,2	22	
MD 65-160/15	15 + 15	54		39,5														38,2	37,4	36,9	36,4	35,2	33	31,2	28,3	27,1	
MD 65-200/18,5	18,5 + 18,5	78		55														53,5	52,3	51,5	50,7	48,7	45	42,2	37		
MD 65-200/22	22 + 22	86		61														59,5	58,4	57,8	57,1	55,5	54	50,1	46		
MMD 65-250/22	22 + 22	89		65														64	63	62	61	58	53				
MMD 65-250/30	30 + 30	116		78															76	75	74	72	66	60			
MMD 65-250/37	37 + 37	142		86,5															85	84	83	80	75	70			

DIMENSIONAL DRAWINGS 2GP MD/MMD

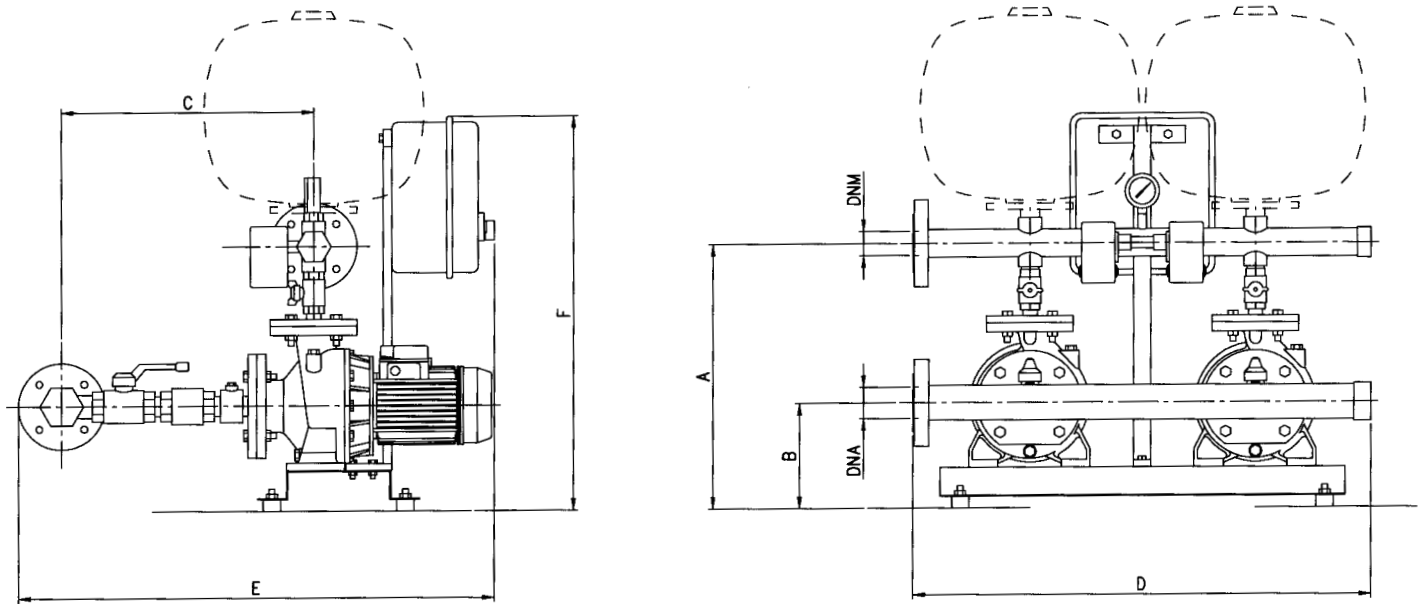

DIMENSIONAL TABLE

Model	Dimensions (mm)								Weight Kg
	A	B	C	D	E	F	DNA	DNM	
2GP MD 32 -160/1,5	600	232	413	800	878	1000	80	2 ¹ / ₂	139
2GP MD 32 -160/2.2	600	232	413	800	878	1000	80	2 ¹ / ₂	143
2GP MD 32 -200/3.0	630	260	413	800	928	1000	80	2 ¹ / ₂	157
2GP MD 32 -200/4.0	630	260	413	800	928	1000	80	2 ¹ / ₂	176
2GP MMD 32 -250/7.5	695	280	433	800	1073	1000	80	2 ¹ / ₂	209
2GP MMD 32 -250/10	695	280	433	800	1073	1000	80	2 ¹ / ₂	238
2GP MMD 32 -250/12.5	695	280	433	800	1073	1000	80	2 ¹ / ₂	247
2GP MD 40 -160/3.0	600	232	433	800	898	1100	100	80	167
2GP MD 40 -160/4.0	600	232	433	800	898	1100	100	80	187
2GP MD 40 -200/5.5	630	260	453	800	988	1100	100	80	216
2GP MD 40 -200/7.5	630	260	453	800	1093	1100	100	80	231
2GP MMD 40 -250/10	695	280	453	800	1093	1100	100	80	251
2GP MMD 40 -250/12.5	695	280	453	800	1093	1100	100	80	277
2GP MMD 40 -250/15	695	280	453	800	1093	1100	100	80	291
2GP MD 50 -160/5.5	630	260	463	800	908	1100	150	100	215
2GP MD 50 -160/7.5	630	260	463	800	1103	1100	150	100	248
2GP MD 50 -200/9.2	695	260	463	800	1103	1100	150	100	258
2GP MD 50 -200/11	695	260	463	800	1103	1100	150	100	264
2GP MMD 50 -250/15	740	280	463	800	1103	1100	150	100	300
2GP MMD 50 -250/18.5	740	280	463	800	1103	1100	150	100	370
2GP MMD 50 -250/22	740	280	463	800	1103	1100	150	100	406
2GP MD 65 -160/11	695	260	473	1000	1113	1200	150	125	275
2GP MD 65 -160/15	695	260	473	1000	1113	1200	150	125	297
2GP MD 65 -200/18.5	740	280	473	1000	1273	1200	150	125	379
2GP MD 65 -200/22	740	280	473	1000	1273	1200	150	125	415
2GP MMD 65 -250/22	785	300	473	1000	1283	1200	150	125	415
2GP MMD 65 -250/30	785	300	473	1000	1378	1200	150	125	479
2GP MMD 65 -250/37	785	300	473	1000	1378	1200	150	125	515

PRESSURE BOOSTER SETS WITH 2 "EVM" OR "EVMG" SERIES VERTICAL MULTISTAGE PUMPS WITH STANDARDISED MOTOR AS THE MAIN PUMPS AND 1 "EVM" PILOT PUMP



TECHNICAL CHARACTERISTICS

The set base and manifolds are of galvanized steel. The delivery manifold can accept a further 3 vertical-type diaphragm tanks, 3 pressure switches, the control panel and a pressure gauge are all positioned on the manifold. Each pump has a suction gate valve, non-return valve and delivery gate valve. Each pump can also be connected to an air feeder. The control panel is held up by a support that is fixed to the base. The pilot pump maintains the system pressure, reintegrating any leaks or small extractions without causing the power motors to start.

CE marked control panel

- Components IMQ and VDE marked.
- Very low voltage auxiliary circuit.
- Motor starting and stopping is controlled by 3 pressure switches.
- Can be connected to floats or low pressure switches to stop operation if there is no supply water.
- Equipped with a device that alternates the lead pump at each starting.
- Supply:
 - three phase 400 V, 50 Hz
- Starting:
 - direct on line for powers up to 7,5 kW
 - star/triangle for powers above 7,5 KW
- Power circuit protection fuses
- Auxiliary circuit protection fuses
- IP 55 protection
- Door interlocked isolator
- Aut. - 0 - man. switches for each pump
- Thermal protection reset
- Pilot LED:
 - mains power
 - pump running
 - level alarm
 - pump being protected (only for three phase version)
- Special versions of panels can be used upon request

WORKING PRINCIPLE

If there is a water demand while the pumps are stopped, the pressure in the system drops. As a consequence the highest-set pressure switch contact closes, and this causes the pilot pump to start. If the required flow is greater than the capacity of one pump, the pressure continues to drop until the second pressure switch contact and/or third one closes and one main pumps or both start. Stopping or reducing the outgoing flow raises the system pressure, which in turn causes the pressure switch contact to open and allows the pumps to stop in turn. Alternating the starting order of the two pumps reduces the number of hourly starts of the lead pump and balances their running times. Connecting a low level float in the supply tank or a low pressure switch in the system, wired through to the control panel will protect against the most frequent cause of pump failure: dry running.

PERFORMANCE CURVES 2+1GP EVM 8 (according to ISO 9906 grade 2)

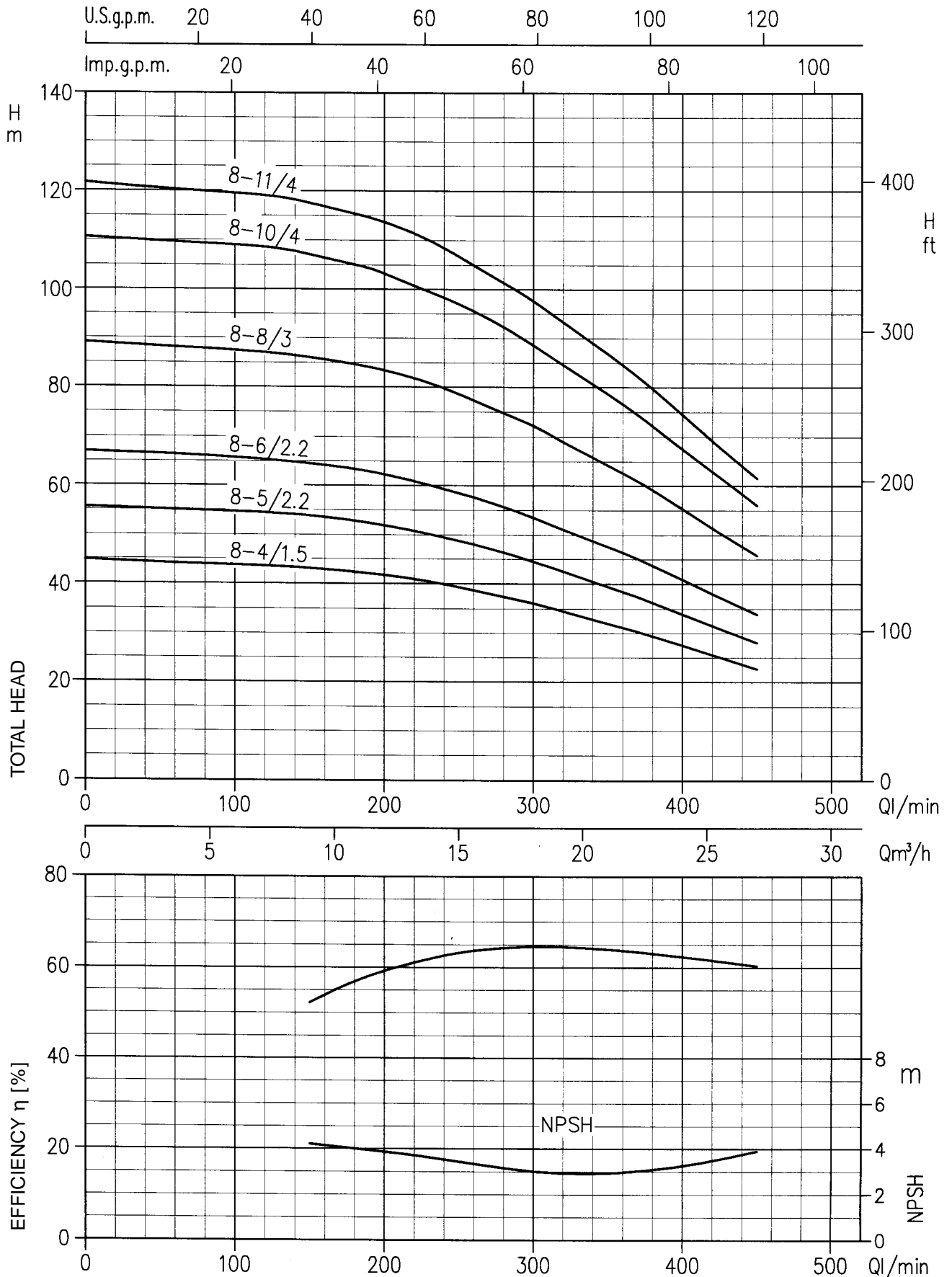

PERFORMANCE CURVES 2+1GP EVM 16 (according to ISO 9906 grade 2)

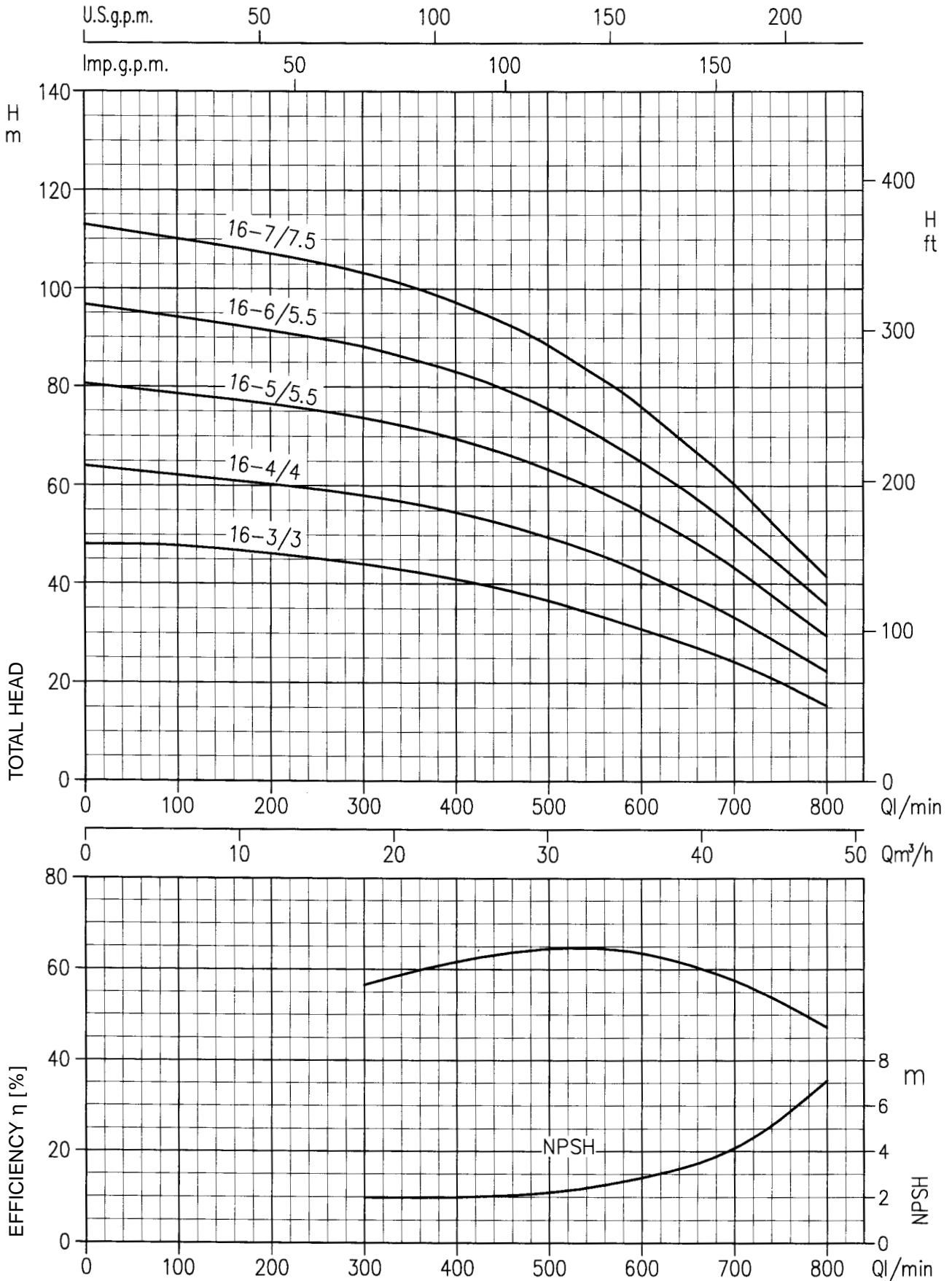

PERFORMANCE CURVES 2+1GP EVM(G) 30 (according to ISO 9906 grade 2)

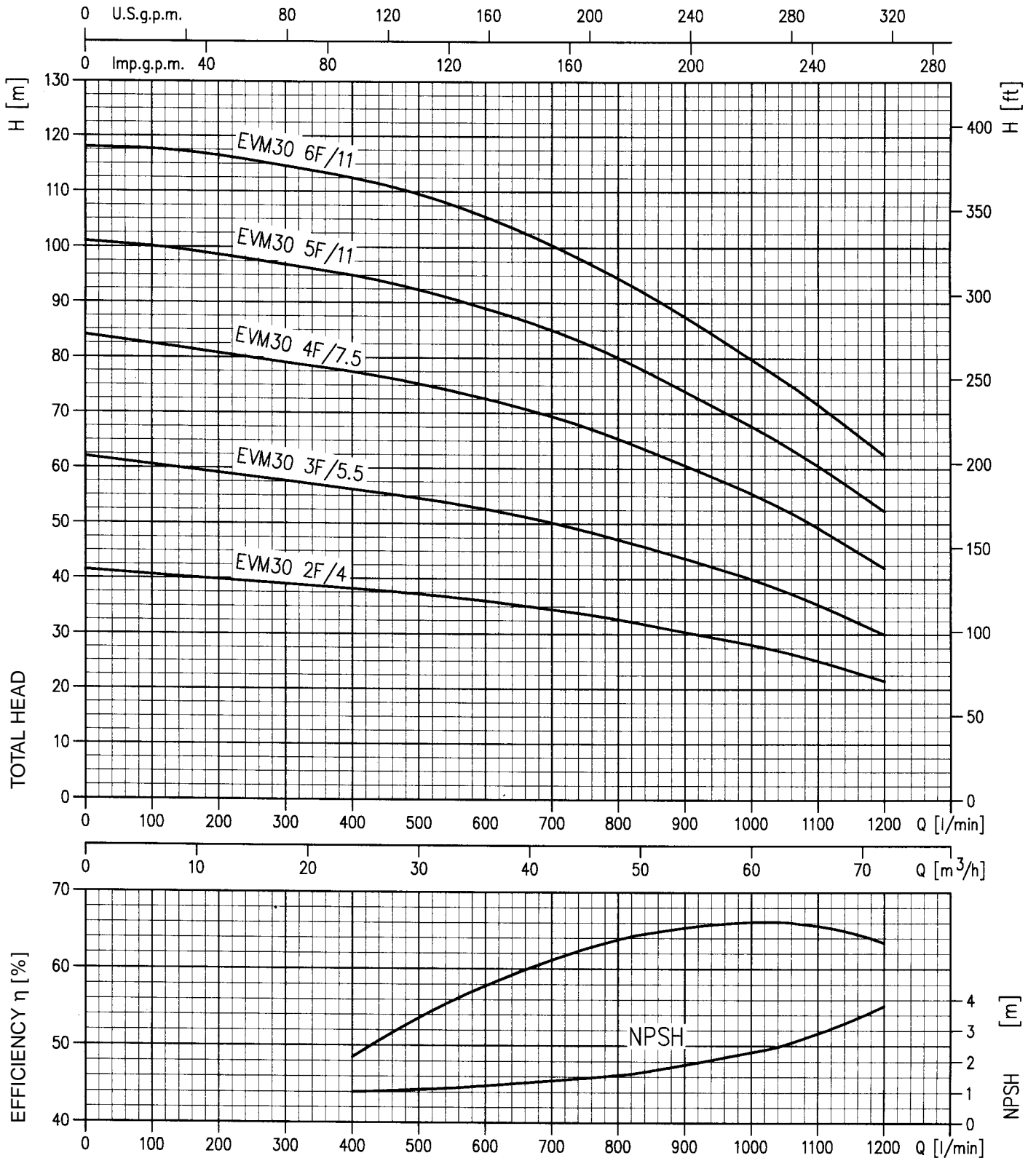

PERFORMANCE CURVES 2+1GP EVM(G) 60 (according to ISO 9906 grade 2)

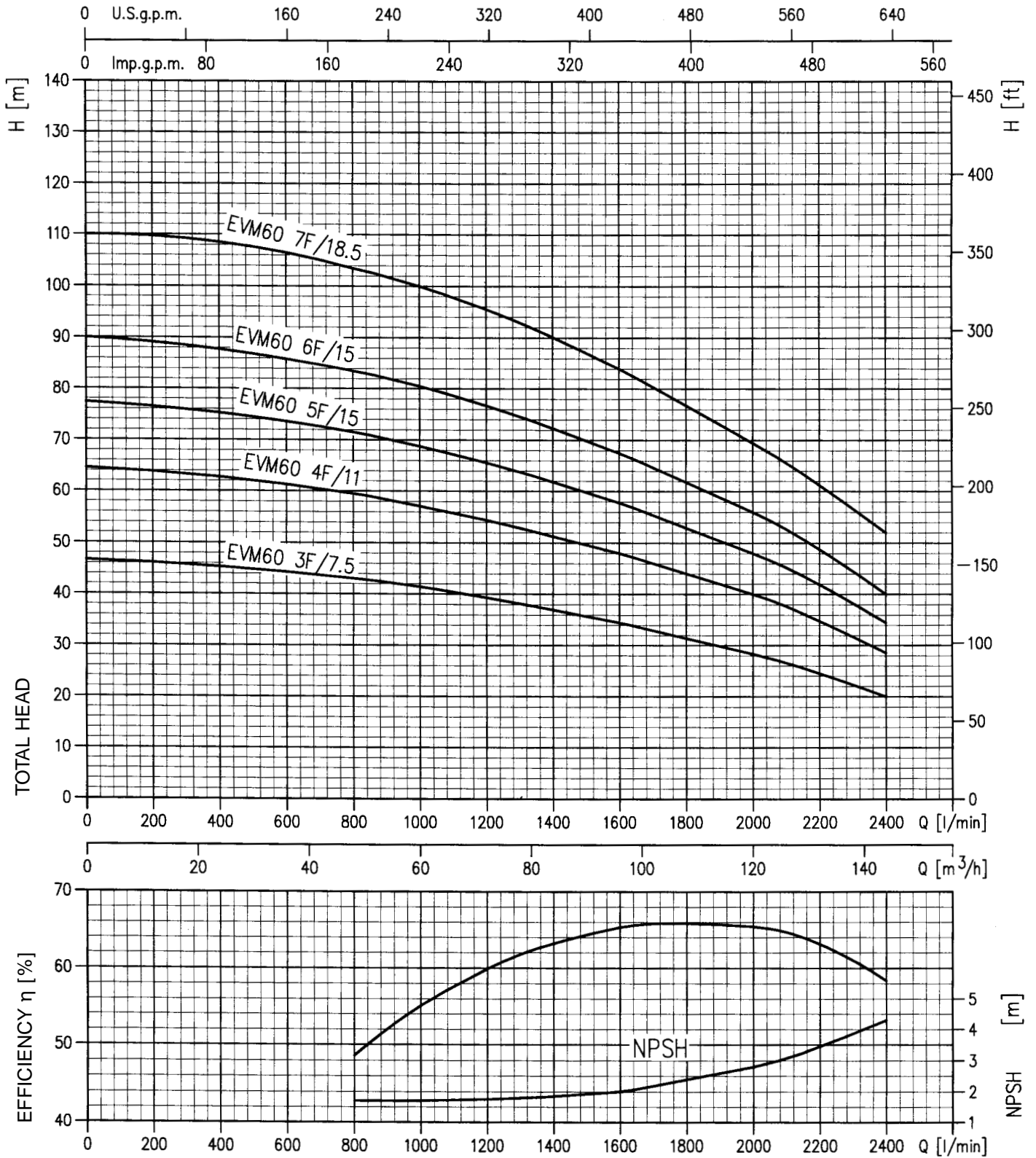

PERFORMANCE TABLE OF THE TWO PUMPS WORKING TOGETHER

Pump type three phase 400 V		kW	Absor. curr. (A)	Q=Capacity																					
Main pumps	Pilot pump			H=Total head [m]																					
				0		160		200		240		300		350		400		450		500		600		700	
		l/min		m ³ /h																					
EVM8 4N/1,5	EVM2 5N/0,55	1,5 + 1,5 + 0,55	7,95	49,4	42,2	41,8	40,0	36,1	31,5	27,7	22,6														
EVM8 5N/2,2	EVM2 6N/0,75	2,2 + 2,2 + 0,75	10,4	59,3	53,0	51,8	49,1	44,3	40,0	34,0	28,3														
EVM8 6N/2,2	EVM2 7N/0,75	2,2 + 2,2 + 0,75	10,4	69,9	64,2	62,0	59,0	53,6	47,0	40,9	33,8														
EVM8 8N/3	EVM2 9N/1,1	3 + 3 + 1,1	14,9	88,9	85,0	83,2	80,2	72,5	64,8	55,0	45,8														
EVM8 10N/4	EVM2 11N/1,1	4 + 4 + 1,1	18,7	88,9	106,0	103,2	98,4	87,8	79,8	67,5	56,5														
EVM8 11N/4	EVM2 13N/1,5	4 + 4 + 1,5	19,7	129,0	116,2	113,2	108,0	97,8	88,0	74,5	61,4														
EVM16 3F/3	EVM2 5N/0,55	3 + 3 + 0,55	13,95	49,4				43,6	42,0	40,0	38,1	36,0	30,7	23,8	15,4										
EVM16 4F/4	EVM2 7N/7,5	4 + 4 + 0,75	18	69,9				58,2	56,4	54,4	52,0	49,7	42,3	33,4	22,3										
EVM16 5F/5,5	EVM2 9N/1,1	5,5 + 5,5 + 1,1	25,3	88,9				73,8	71,5	69,0	67,1	63,7	54,9	43,6	29,5										
EVM16 6F/5,5	EVM2 11N/1,1	5,5 + 5,5 + 1,1	25,3	108,0				88,3	85,3	82,2	79,8	75,8	65,0	52,3	35,8										
EVM16 7F/7,5	EVM2 11N/1,1	7,5 + 7,5 + 1,1	32,9	113,0				103,3	99,5	96,0	92,5	88,2	76,5	60,0	41,3										

Pump type three phase 400 V		kW	Absor. curr. (A)	Q=Capacity																													
Main pumps	Pilot pump			H=Total head [m]																													
				0		200		300		400		500		600		666		800		900		1000		1100		1200		1400		1600		2000	
		l/min		m ³ /h																													
EVM(G) 30 2F/4	EVM2 5N/0,55	4 + 4 + 0,55	17,75	49,4	39,8	39	38,2	37,6	36,0	34,8	32,7	30,4	28,1	25	21,5																		
EVM(G) 30 3F/5,5	EVM2 7N/0,75	5 + 5 + 0,75	24,6	69,9	59,1	58	56,2	54,0	52,5	50,5	47,2	44,0	40	35,5	30																		
EVM(G) 30 4F/7,5	EVM2 9N/1,1	7,5 + 7,5 + 1,1	32,9	88,9	80,8	79,8	77,4	75,0	72,6	70,0	65,6	61,0	55,5	49	42																		
EVM(G) 30 5F/11	EVM2 11N/1,1	11 + 11 + 1,1	43,1	108	98,7	97,7	95,0	92,0	89,0	86,0	80,1	75,0	67,7	60	52,3																		
EVM(G) 30 6F/11	EVM2 13N/1,5	11 + 11 + 1,5	44,1	129	116,5	115,0	112,6	109,8	105,4	102,5	94,6	87,0	79,8	71,5	62,5																		
EVM(G) 60 3F/7,5	EVM2 5N/0,55	7,5 + 7,5 + 0,55	31,95	46,6	49,4						43,0	42	41,5	40,5	39,3	37	34,5	28,3	19,5														
EVM(G) 60 4F/11	EVM2 7N/0,75	11 + 11 + 0,75	42,4	69,9							59,5	58	57	56	54,4	52	48	40	28,5														
EVM(G) 60 5F/15	EVM2 9N/1,1	15 + 15 + 1,1	57,5	88,9							71,5	70	68,5	67	65,6	62,3	57,8	48	34,3														
EVM(G) 60 6F/15	EVM2 11N/1,1	15 + 15 + 1,1	57,5	108,0							83,5	82	80	78	76,7	73	67,5	56	40														
EVM(G) 60 7F/18,5	EVM2 13N/1,5	18,5 + 18,5 + 1,5	67,3	129,0							103,5	102	100	97,5	95,5	90	84	69,5	52														

DIMENSIONAL DRAWINGS 2+1GP EVM(G)

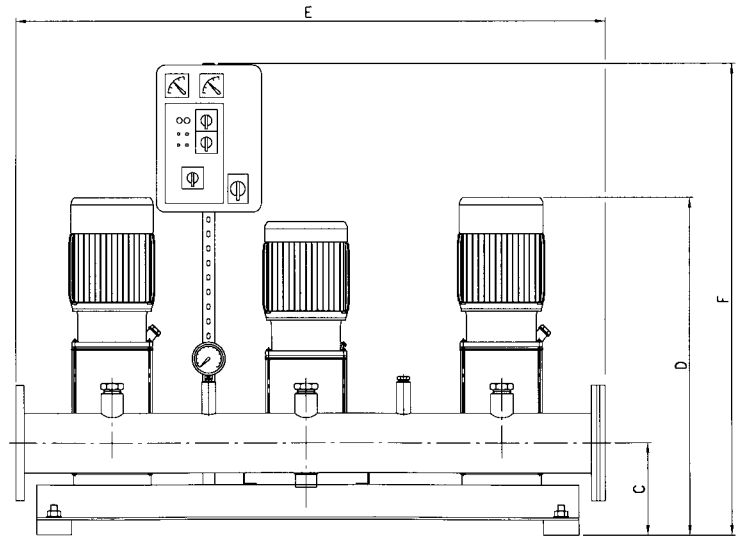
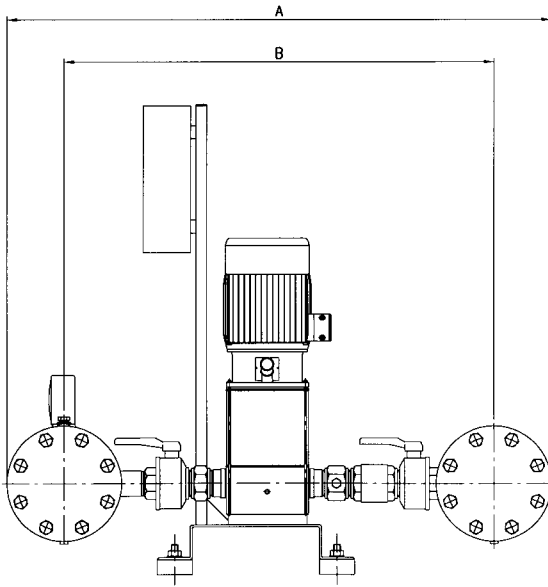

DIMENSIONAL TABLE

Model	Dimensions (mm)							
	A	B	C	D	E	F	DNA	DNM
2+1GP EVM2 4N/0.55	720	651	125	528	1030	880	80	80
2+1GP EVM2 5N/0.55	720	651	125	543	1030	880	80	80
2+1GP EVM2 6N/0.75	720	651	125	610	1030	880	80	80
2+1GP EVM2 7N/0.75	720	651	125	631	1030	880	80	80
2+1GP EVM2 9N/1.1	720	651	125	673	1030	880	80	80
2+1GP EVM2 11N/1.1	720	651	125	715	1030	880	80	80
2+1GP EVM4 5N/1.1	720	651	125	623	1030	880	80	80
2+1GP EVM4 6N/1.1	720	651	125	651	1030	880	80	80
2+1GP EVM4 7N/1.5	720	651	125	693	1030	880	80	80
2+1GP EVM4 8N/1.5	720	651	125	721	1030	880	80	80
2+1GP EVM4 10N/2.2	720	651	125	804	1030	880	80	80
2+1GP EVM4 11N/2.2	720	651	125	832	1030	880	80	80
2+1GP EVM4 12N/2.2	720	651	125	915	1030	1000	80	80
2+1GP EVM8 4N/1.5	862	762	155	690	1030	1000	100	100
2+1GP EVM8 5N/2.2	862	762	155	747	1030	1000	100	100
2+1GP EVM8 6N/2.2	862	762	155	777	1030	1000	100	100
2+1GP EVM8 8N/3.0	862	762	155	892	1030	1000	100	100
2+1GP EVM8 10N/3.0	862	762	155	982	1030	1000	100	100
2+1GP EVM8 11N/4.0	862	762	155	1012	1030	1000	100	100
2+1GP EVM16 3F/3.0	1184	964	165	782	1500	1000	125	125
2+1GP EVM16 4F/4.0	1184	964	165	822	1500	1000	125	125
2+1GP EVM16 5F/5.5	1184	964	165	942	1500	1000	125	125
2+1GP EVM16 6F/5.5	1184	964	165	982	1500	1000	125	125
2+1GP EVM16 7F/7.5	1184	964	165	1022	1500	1000	125	125
2+1GP EVM(G) 30 2F/4.0	1650	1500	205	903	1800	1800	150	150
2+1GP EVM(G) 30 3F/5.5	1650	1500	205	1038	1800	1800	150	150
2+1GP EVM(G) 30 4F/7.5	1650	1500	205	1086	1800	1800	150	150
2+1GP EVM(G) 30 5F/11	1650	1500	205	1290	1800	1800	150	150
2+1GP EVM(G) 30 6F/11	1650	1500	205	1338	1800	1800	150	150
2+1GP EVM(G) 60 3F/7.5	1890	1690	240	1163	1800	1800	200	200
2+1GP EVM(G) 60 4F/11	1890	1690	240	1390	1800	1800	200	200
2+1GP EVM(G) 60 5F/15	1890	1690	240	1462	1800	1800	200	200
2+1GP EVM(G) 60 6F/15	1890	1690	240	1534	1800	1800	200	200
2+1GP EVM(G) 60 7F/18.5	1890	1690	240	1606	1800	1800	200	200

PRESSURE BOOSTER SETS WITH 2 "3M" SERIES HORIZONTAL MONO-BLOCK PUMPS DERIVED FROM EN 733 (ex DIN 24255) WITH STAINLESS STEEL HYDRAULICS AS THE MAIN PUMPS AND 1 "2CDX" OR "COMPACT" TO BE USED AS THE PILOT PUMP



TECHNICAL CHARACTERISTICS

The set base and manifolds are of galvanized steel. The delivery manifold can accept a further 3 vertical-type diaphragm tanks, 3 pressure switches, the control panel and a pressure gauge are all positioned on the manifold. Each pump has a suction gate valve, non-return valve and delivery gate valve. Each pump can also be connected to an air feeder. The control panel is held up by a support that is fixed to the base. The pilot pump maintains the system pressure, reintegrating any leaks or small extractions without causing the power motors to start.

CE marked control panel

- Components IMQ and VDE marked.
- Very low voltage auxiliary circuit.
- Motor starting and stopping is controlled by 3 pressure switches.
- Can be connected to floats or low pressure switches to stop operation if there is no supply water.
- Equipped with a device that alternates the lead pump at each starting.
- Supply:
 - three phase 400 V, 50 Hz
- Starting:
 - direct on line for powers up to 7,5 kW
 - star/triangle for powers above 7,5 KW
- Power circuit protection fuses
- Auxiliary circuit protection fuses
- IP 55 protection
- Door interlocked isolator
- Aut. - 0 - man. switches for each pump
- Thermal protection reset
- Pilot LED:
 - mains power
 - pump running
 - level alarm
 - pump being protected (only for three phase version)
- Special versions of panels can be used upon request

WORKING PRINCIPLE

If there is a water demand while the pumps are stopped, the pressure in the system drops. As a consequence the highest-set pressure switch contact closes, and this causes the pilot pump to start. If the required flow is greater than the capacity of one pump, the pressure continues to drop until the second pressure switch contact and/or third one closes and one main pumps or both start. Stopping or reducing the outgoing flow raises the system pressure, which in turn causes the pressure switch contact to open and allows the pumps to stop in turn. Alternating starting order of the two pumps reduces the number of hourly starts of the lead pump and balances their running times. Connecting a low level float in the supply tank or a low pressure switch in the system, wired through to the control panel will protect against the most frequent cause of pump failure: dry running.

PERFORMANCE CURVES 2+1GP 3M 32 (according to ISO 9906 grade 2)

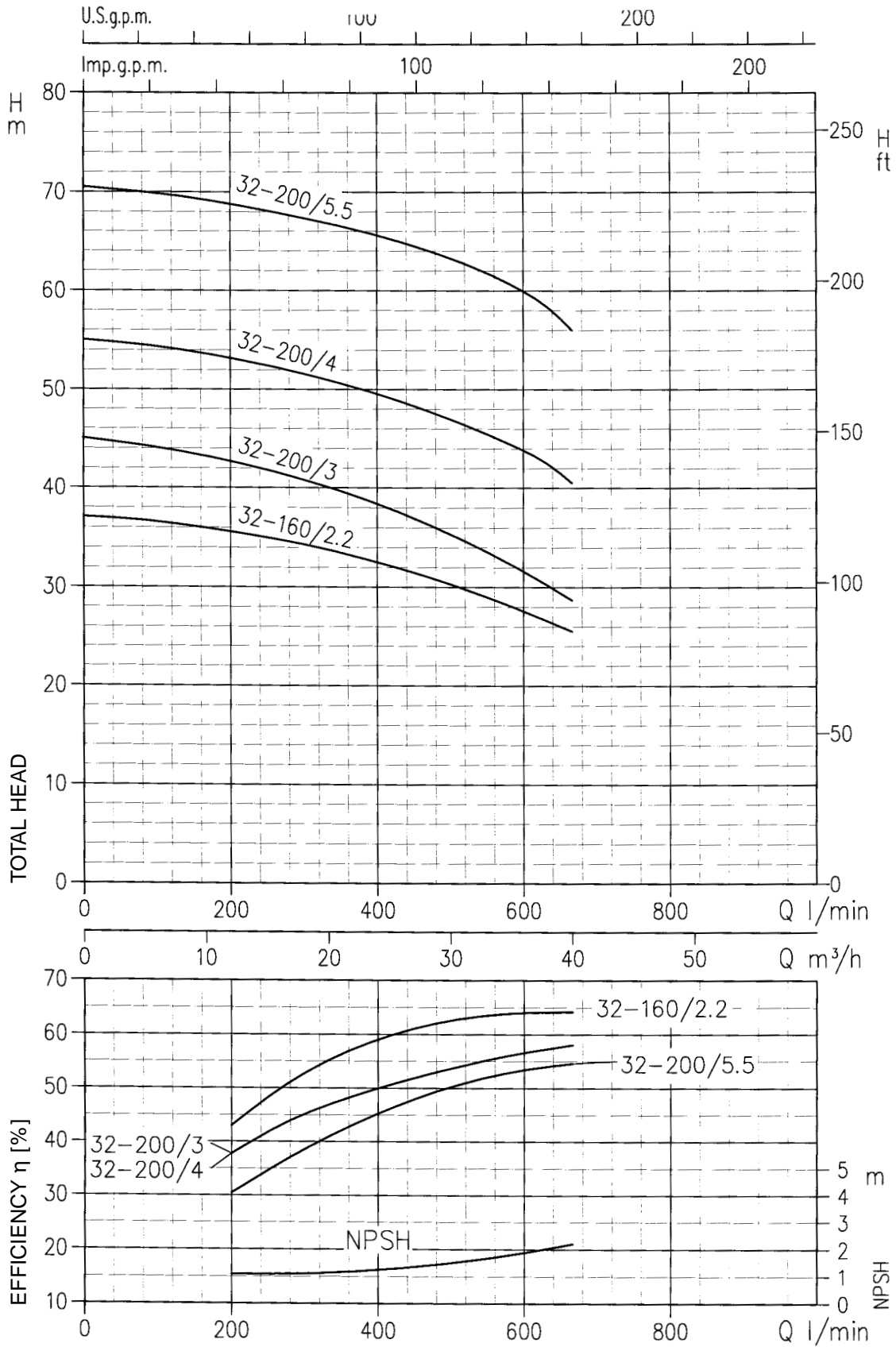

PERFORMANCE CURVES 2+1GP 3M 40 (according to ISO 9906 grade 2)

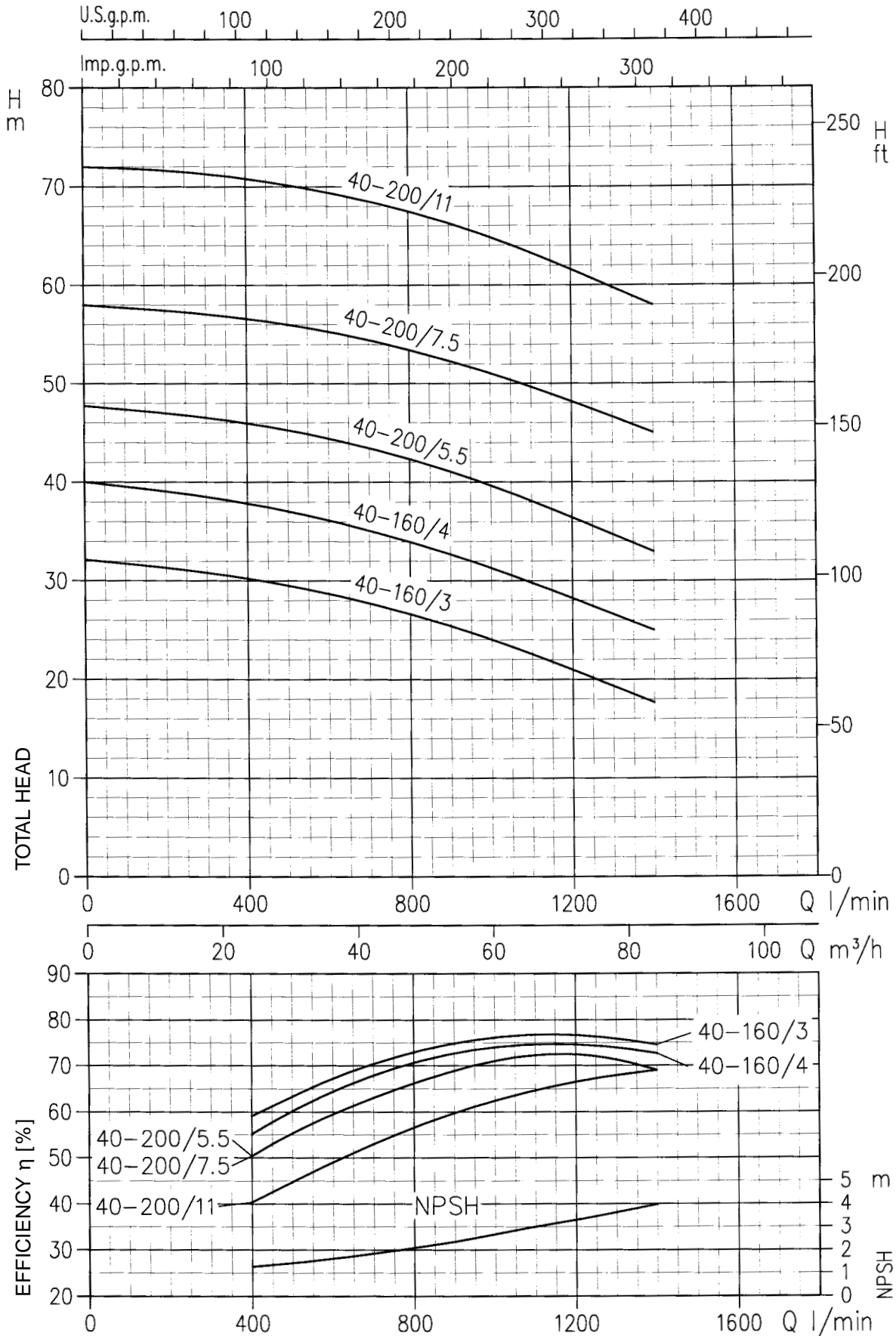

PERFORMANCE CURVES 2+1GP 3M 50 (according to ISO 9906 grade 2)

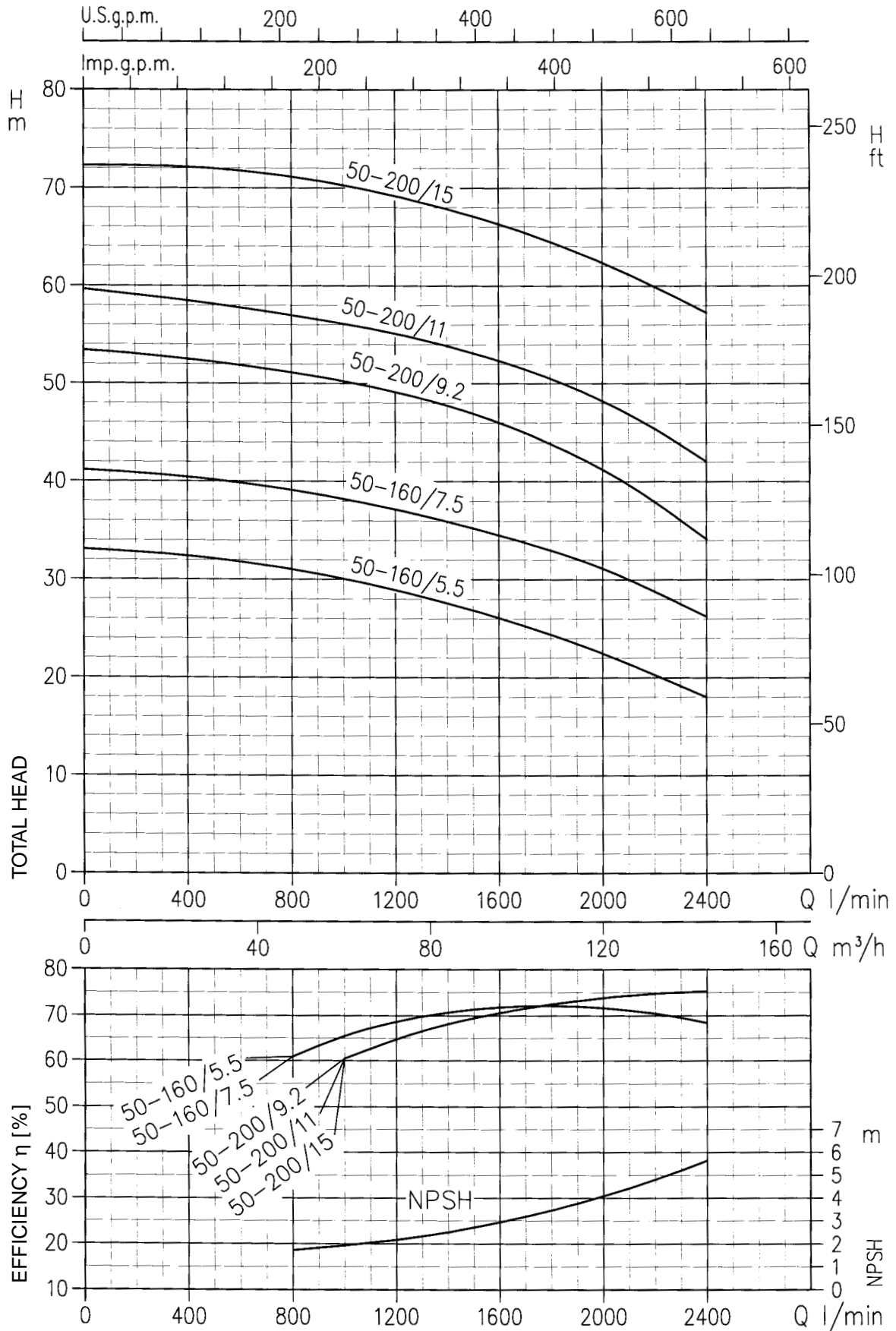

PERFORMANCE TABLE OF THE TWO PUMPS WORKING TOGETHER

Pump type (three phase 400 V)		kW	Abs. curr. (A)	Q=Capacity																	
Main pumps	Pilot pump			l/min	200	300	400	500	560	600	666	800	900	1000	1100	1200	1400	1600	2000	2200	2400
		H=Total head [m]																			
		0	12	18	24	30	33.6	36	40	48	54	60	66	72	84	96	120	132	144		
2+1 GP 3M 32-160/2.2	2CDX 70/10	2.2+2.2+0.75	11.9	41	35.5	34.5	32.5	30.5	29	27.5	25.5	-	-	-	-	-	-	-	-	-	
2+1 GP 3M 32-200/3.0	2CDX 70/12	3+3+0.88	16.5	49	42.5	41	38.5	35	33.5	31.5	29	-	-	-	-	-	-	-	-	-	
2+1 GP 3M 32-200/4.0	2CDX 70/20	4+4+1.5	22	64	53	51.5	49.5	47	45.5	43.5	40.5	-	-	-	-	-	-	-	-	-	
2+1 GP 3M 32-200/5.5	COMPACT A12	5.5+5.5+0.9	27	74	69	67.6	65.5	63	61.8	60	56	-	-	-	-	-	-	-	-	-	
2+1 GP 3M 40-160/3.0	2CDX 70/10	3+3+0.75	15.9	41	-	-	30	29	28.8	28.5	27.3	26.2	25.4	24	22.5	21	17.5	-	-	-	
2+1 GP 3M 40-160/4.0	2CDX 70/12	4+4+0.88	21.3	49	-	-	38	37	36.6	36	35	34	33	31.3	30	28.5	25	-	-	-	
2+1 GP 3M 40-200/5.5	2CDX 70/15	5.5+5.5+1.1	25.4	56	-	-	46	45	44.6	44	43.5	42	41	40	38.5	37	33	-	-	-	
2+1 GP 3M 40-200/7.5	2CDX 70/20	7.5+7.5+1.5	34.2	64	-	-	56.5	56.0	55.7	55.3	55.0	53.5	52.5	51.2	49.8	48.5	45.0	-	-	-	
2+1 GP 3M 40-200/11	COMPACT A15	11+11+1.1	42.5	86	-	-	71	70	69.7	69.3	68.8	67.5	66.2	65	63.5	62	58	-	-	-	
2+1 GP 3M 50-160/5.5	2CDX 70/10	5.5+5.5+0.75	25.3	41	-	-	-	-	-	-	-	31	30.5	30	29.5	29	27.6	26	22.5	20	18
2+1 GP 3M 50-160/7.5	2CDX 70/12	7.5+7.5+0.88	33.9	49	-	-	-	-	-	-	-	39	38.5	38	37.5	37	36	34.5	31	29	26
2+1 GP 3M 50-200/9.2	2CDX 70/15	9.2+9.2+1.1	38	56	-	-	-	-	-	-	-	-	-	50	49.5	49	47.5	46	41	38	34
2+1 GP 3M 50-200/11	2CDX 70/20	11+11+1.5	48	64	-	-	-	-	-	-	-	-	-	56	55.5	55	53.8	52	48	45.4	42
2+1 GP 3M 50-200/15	CDA 5.50T	15+15+4	72.1	80	-	-	-	-	-	-	-	-	-	70	69.5	69	68	66	62	60	57

DIMENSIONAL DRAWINGS 2+1GP 3M

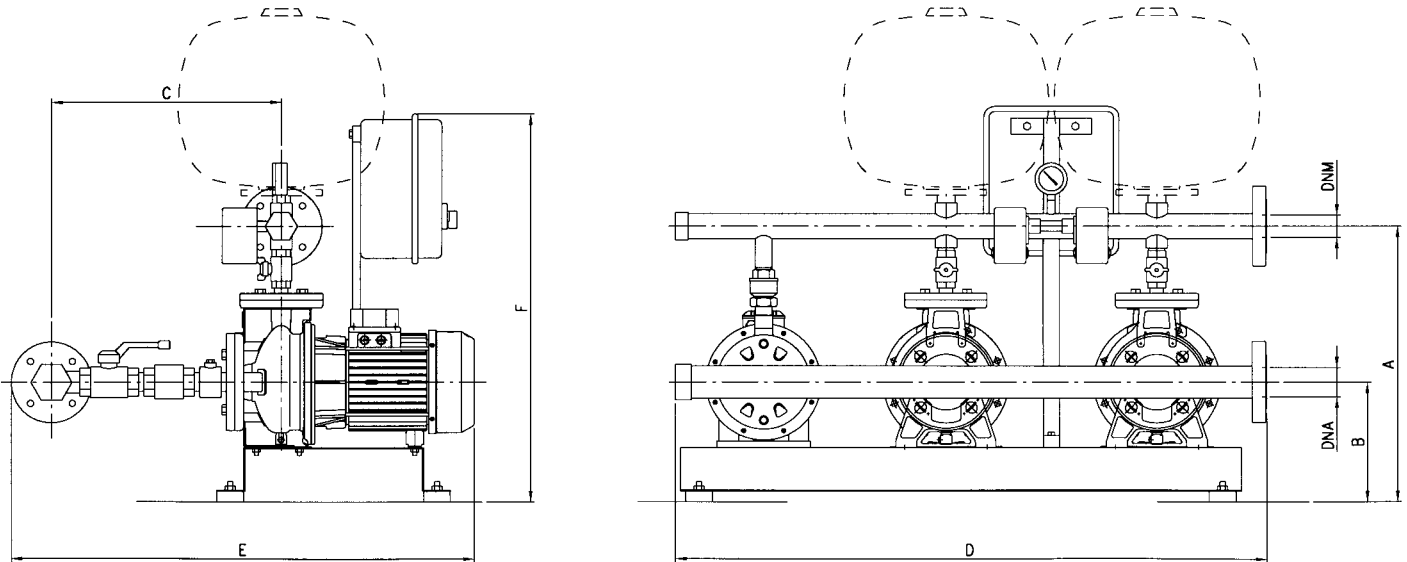

DIMENSIONAL TABLE

Model	Dimensions (mm)							
	A	B	C	D	E	F	DNA	DNM
2+1GP 3M 32-200/3	542	280	313	710	800	1429	80	80
2+1GP 3M 32-200/4	542	280	313	710	800	1429	80	80
2+1GP 3M 32-200/5,5	542	280	313	710	800	1429	80	80
2+1GP 3M 40-200/5,5	646	280	359	779	800	1437	100	100
2+1GP 3M 40-200/7,5	646	280	359	779	800	1437	100	100
2+1GP 3M 40-200/11	646	280	359	779	800	1437	100	100
2+1GP 3M 50-200/9,2	752	280	483	965	800	1674	150	100
2+1GP 3M 50-200/11	601	280	483	965	800	1674	150	100
2+1GP 3M 50-200/15	752	280	483	965	800	1674	150	100

PRESSURE BOOSTER SETS WITH 2 "MD/MMD" SERIES HORIZONTAL MONO-BLOCK PUMPS DERIVED FROM EN 733 (ex DIN 24255) WITH CAST IRON HYDRAULICS AS THE MAIN PUMPS AND 1 "2CDX", "COMPACT" OR "EVM" SERIES AS THE PILOT PUMP



TECHNICAL CHARACTERISTICS

The set base and manifolds are of galvanized steel. The delivery manifold can accept a further 3 vertical-type diaphragm tanks, 3 pressure switches, the control panel and a pressure gauge are all positioned on the manifold. Each pump has a suction gate valve, non-return valve and delivery gate valve. Each pump can also be connected to an air feeder. The control panel is held up by a support that is fixed to the base. The pilot pump maintains the system pressure, reintegrating any leaks or small extractions without causing the power motors to start.

CE marked control panel

- Components IMQ and VDE marked.
- Very low voltage auxiliary circuit.
- Motor starting and stopping is controlled by 3 pressure switches.
- Can be connected to floats or low pressure switches to stop operation if there is no supply water.
- Equipped with a device that alternates the lead pump at each starting.
- Supply:
 - three phase 400 V, 50 Hz
- Starting:
 - direct on line for powers up to 7,5 kW
 - star/triangle for powers above 7,5 KW
- Power circuit protection fuses
- Auxiliary circuit protection fuses
- IP 55 protection
- Door interlocked isolator
- Aut. - 0 - man. switches for each pump
- Thermal protection reset
- Pilot LED:
 - mains power
 - pump running
 - level alarm
 - pump being protected (only for three phase version)
- Special versions of panels can be used upon request

WORKING PRINCIPLE

If there is a water demand while the pumps are stopped, the pressure in the system drops. As a consequence the highest-set pressure switch contact closes, and this causes the pilot pump to start. If the required flow is greater than the capacity of one pump, the pressure continues to drop until the second pressure switch contact and/or third one closes and one main pumps or both start. Stopping or reducing the outgoing flow raises the system pressure, which in turn causes the pressure switch contact to open and allows the pumps to stop in turn. Alternating starting order of the two pumps reduces the number of hourly starts of the lead pump and balances their running times. Connecting a low level float in the supply tank or a low pressure switch in the system, wired through to the control panel will protect against the most frequent cause of pump failure: dry running.

PERFORMANCE CURVES 2+1GP MD 32 (according to ISO 9906 grade 2)

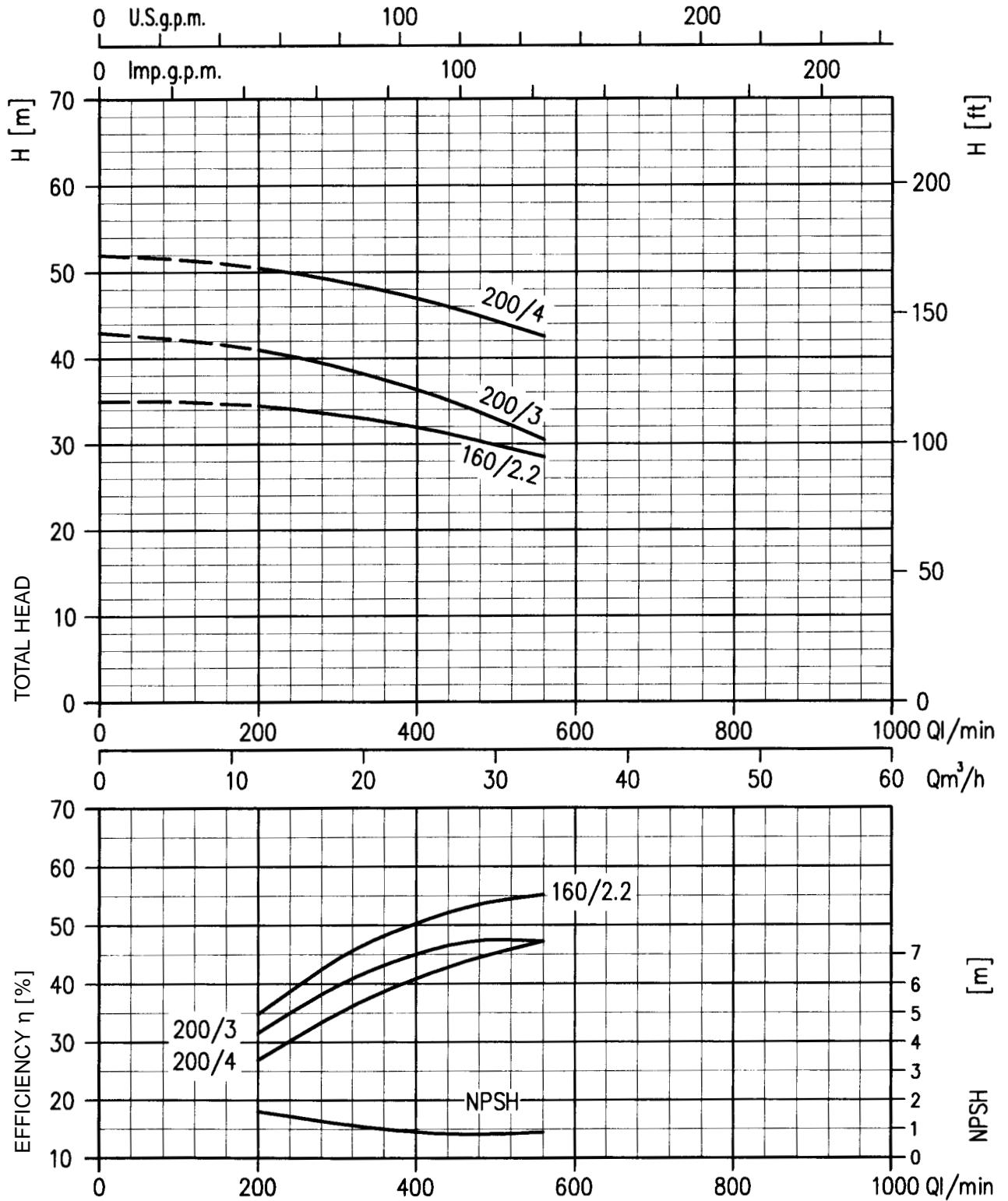

PERFORMANCE CURVES 2+1GP MMD 32 (according to ISO 9906 grade 2)

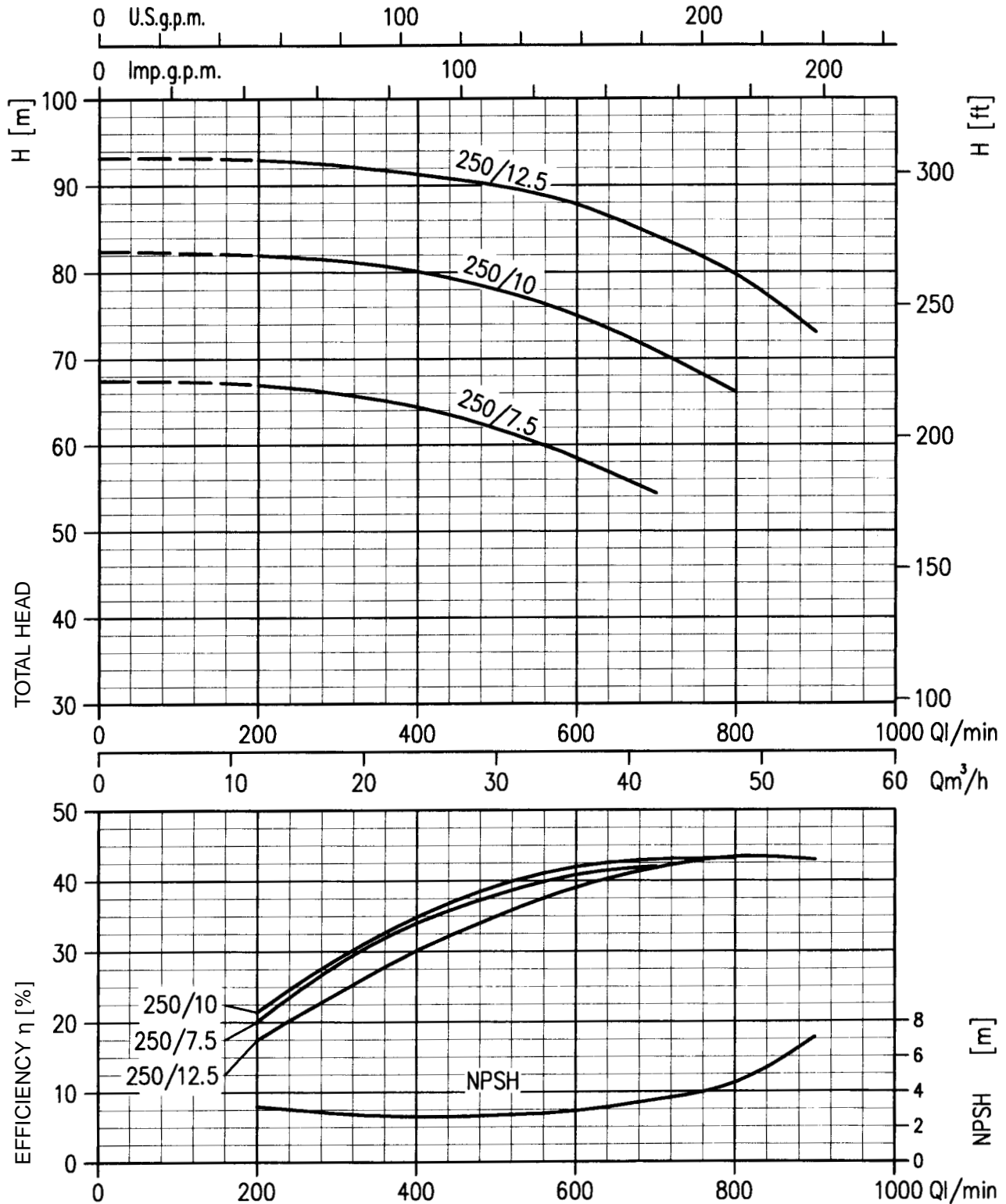

PERFORMANCE CURVES 2+1GP MD 40 (according to ISO 9906 grade 2)

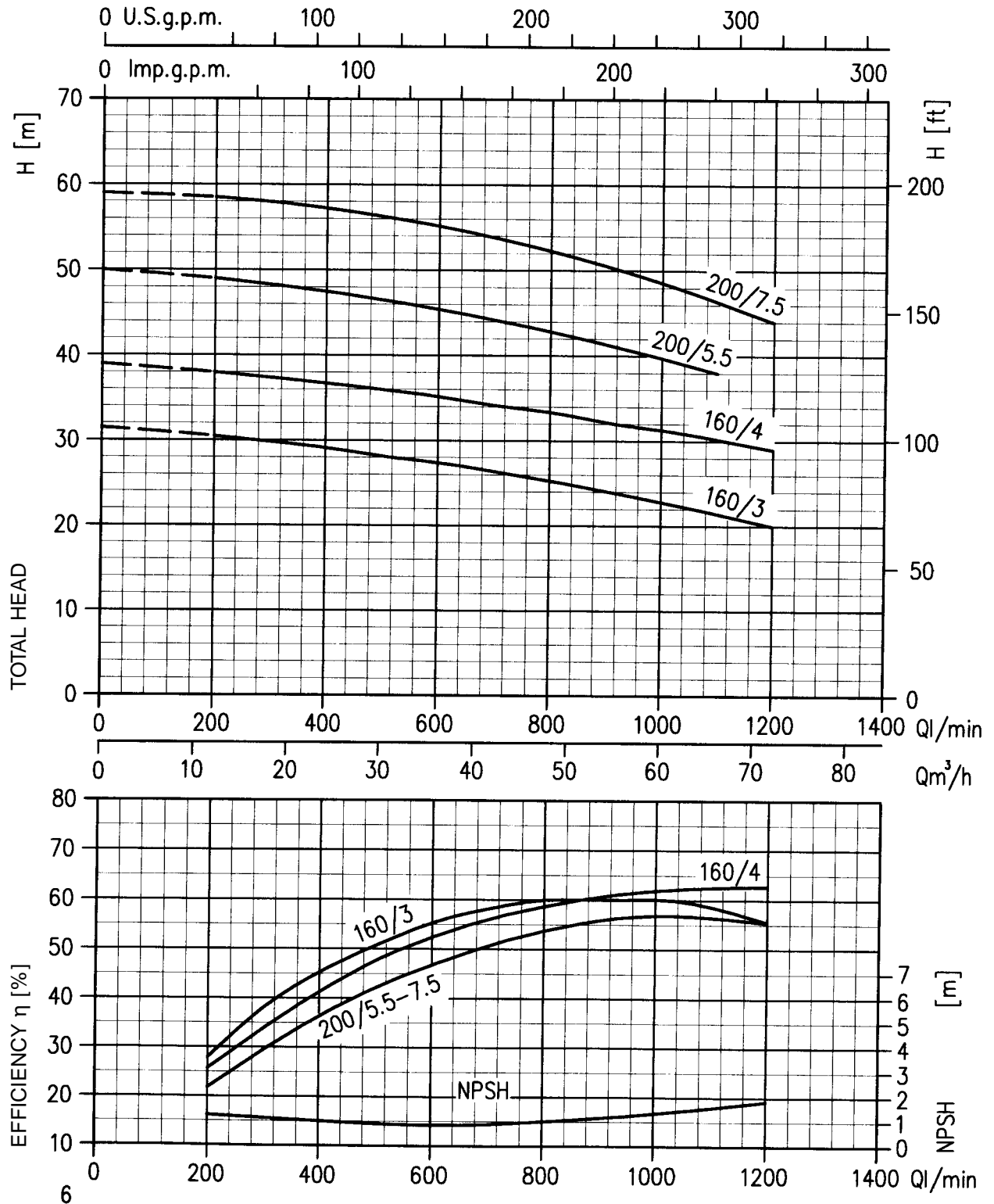

PERFORMANCE CURVES 2+1GP MMD 40 (according to ISO 9906 grade 2)

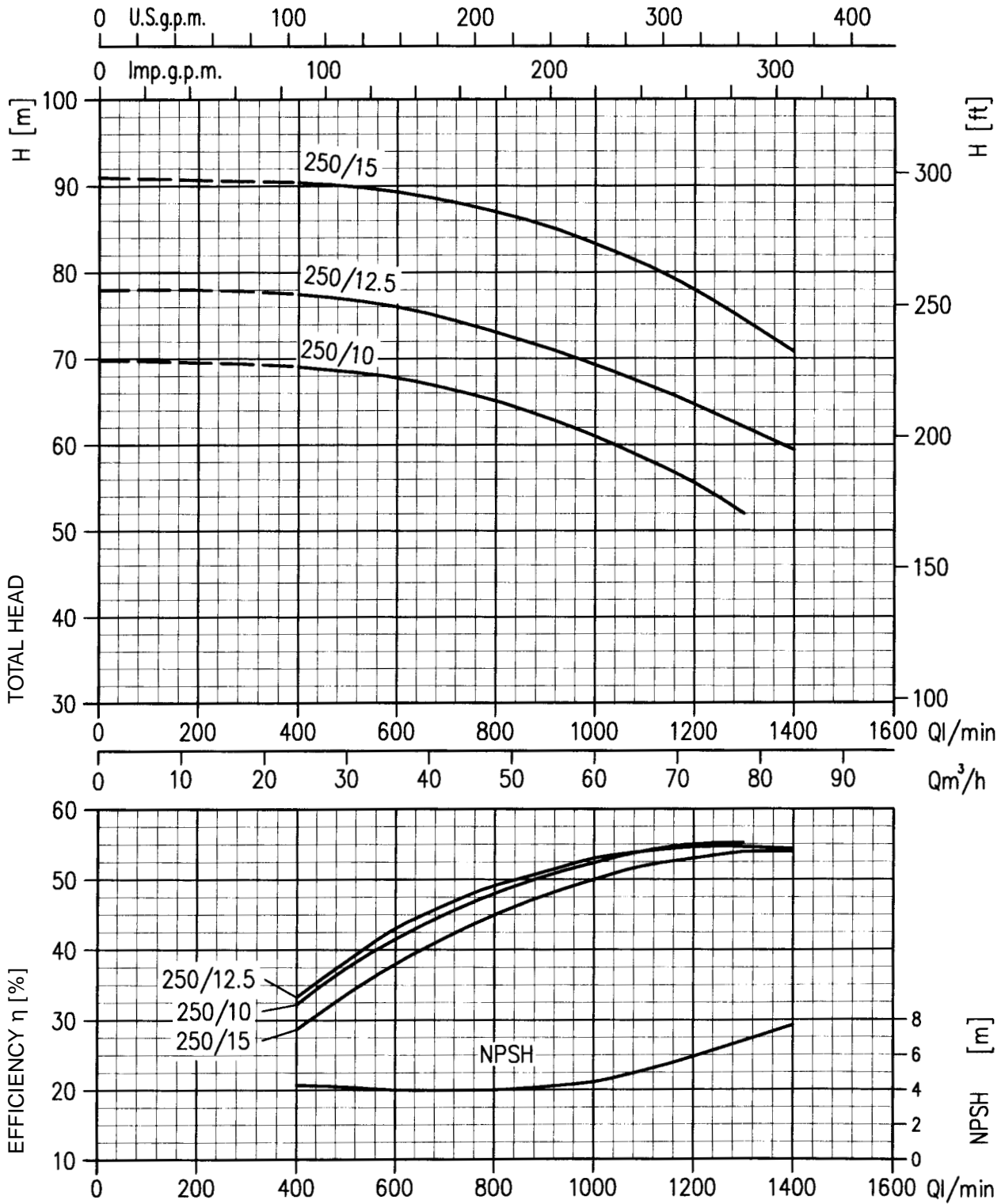

PERFORMANCE CURVES 2+1GP MD 50 (according to ISO 9906 grade 2)

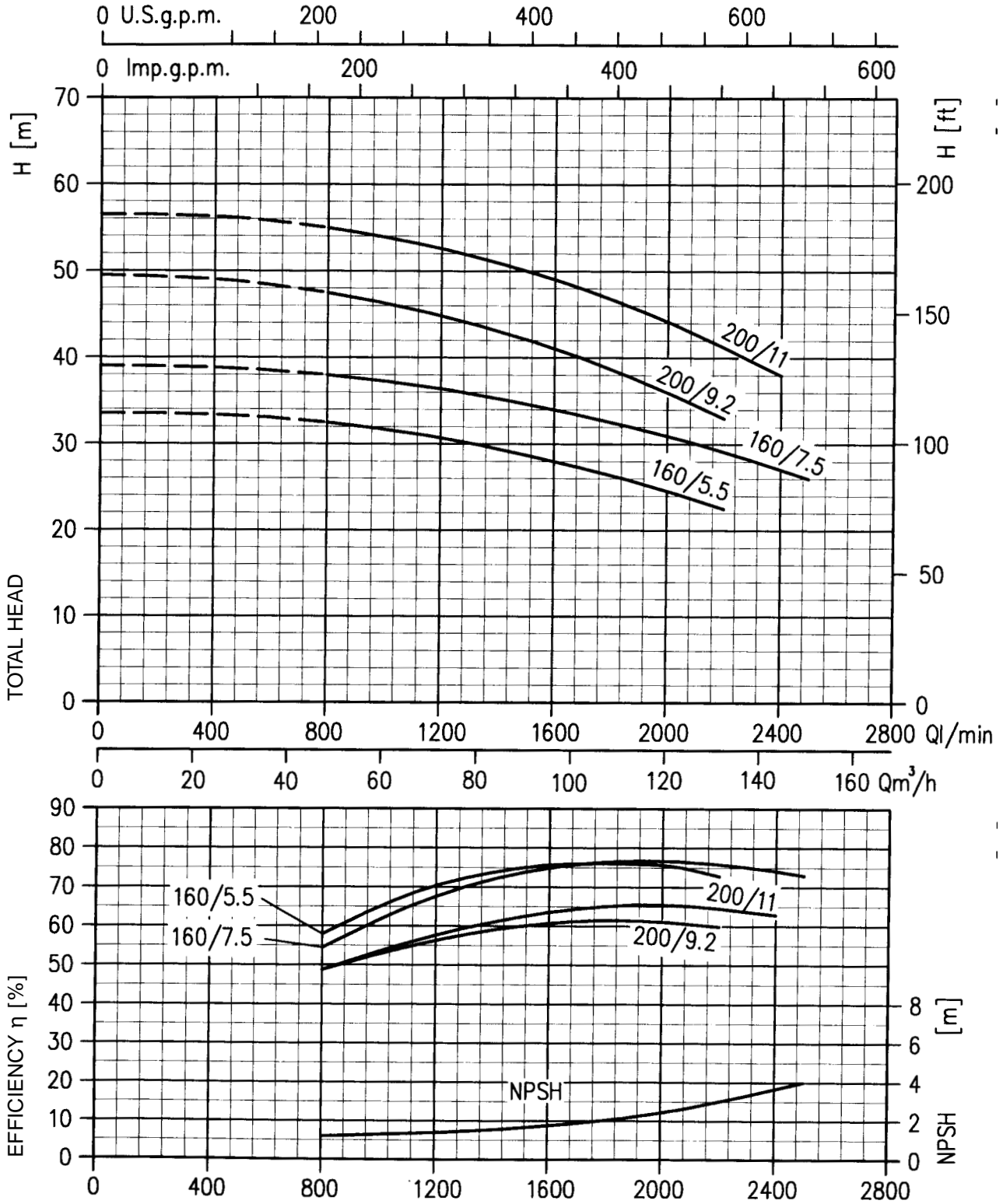

PERFORMANCE CURVES 2+1GP MMD 50 (according to ISO 9906 grade 2)

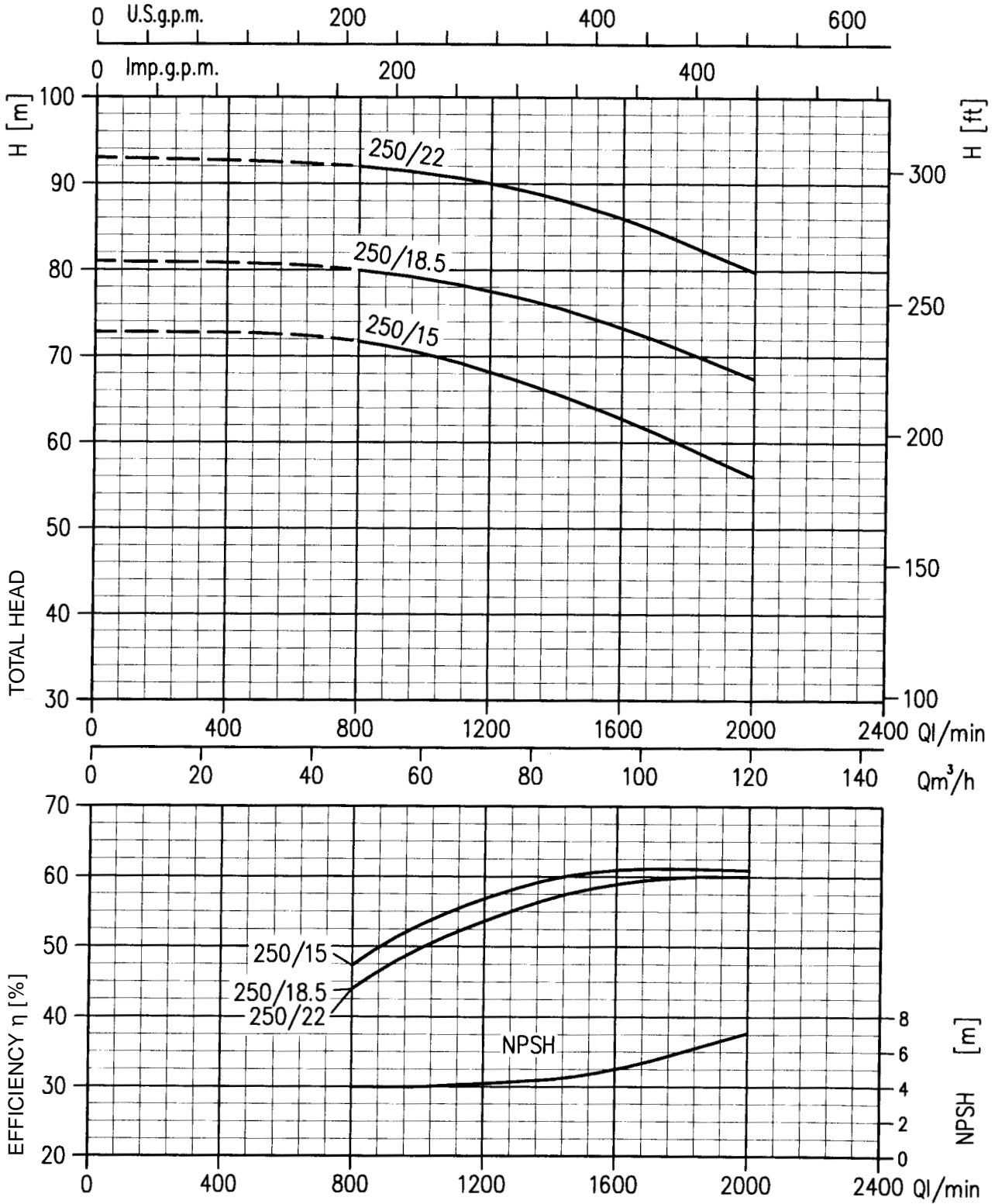

PERFORMANCE CURVES 2+1GP MD 65 (according to ISO 9906 grade 2)

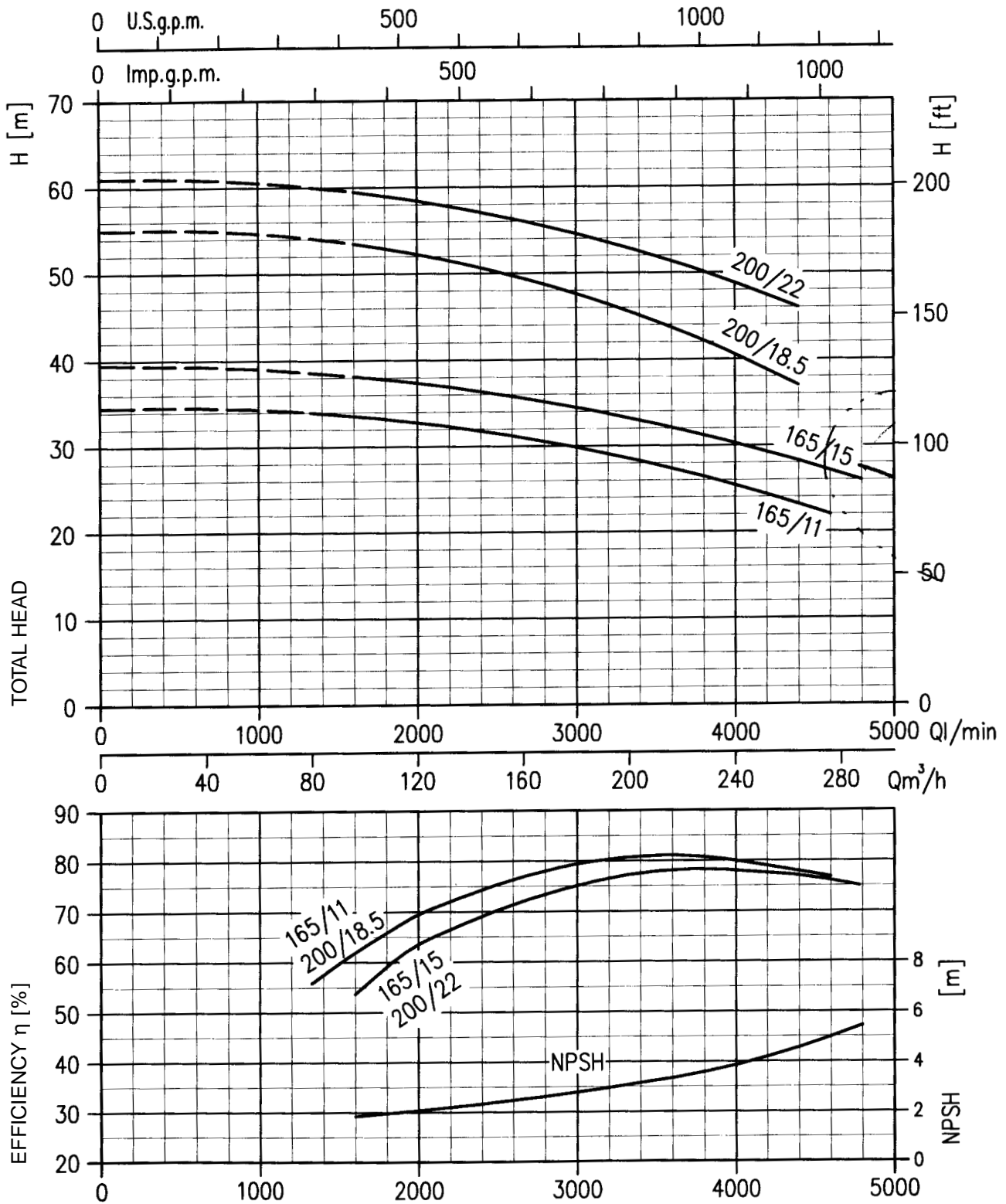

PERFORMANCE CURVES 2+1GP MMD 65 (according to ISO 9906 grade 2)

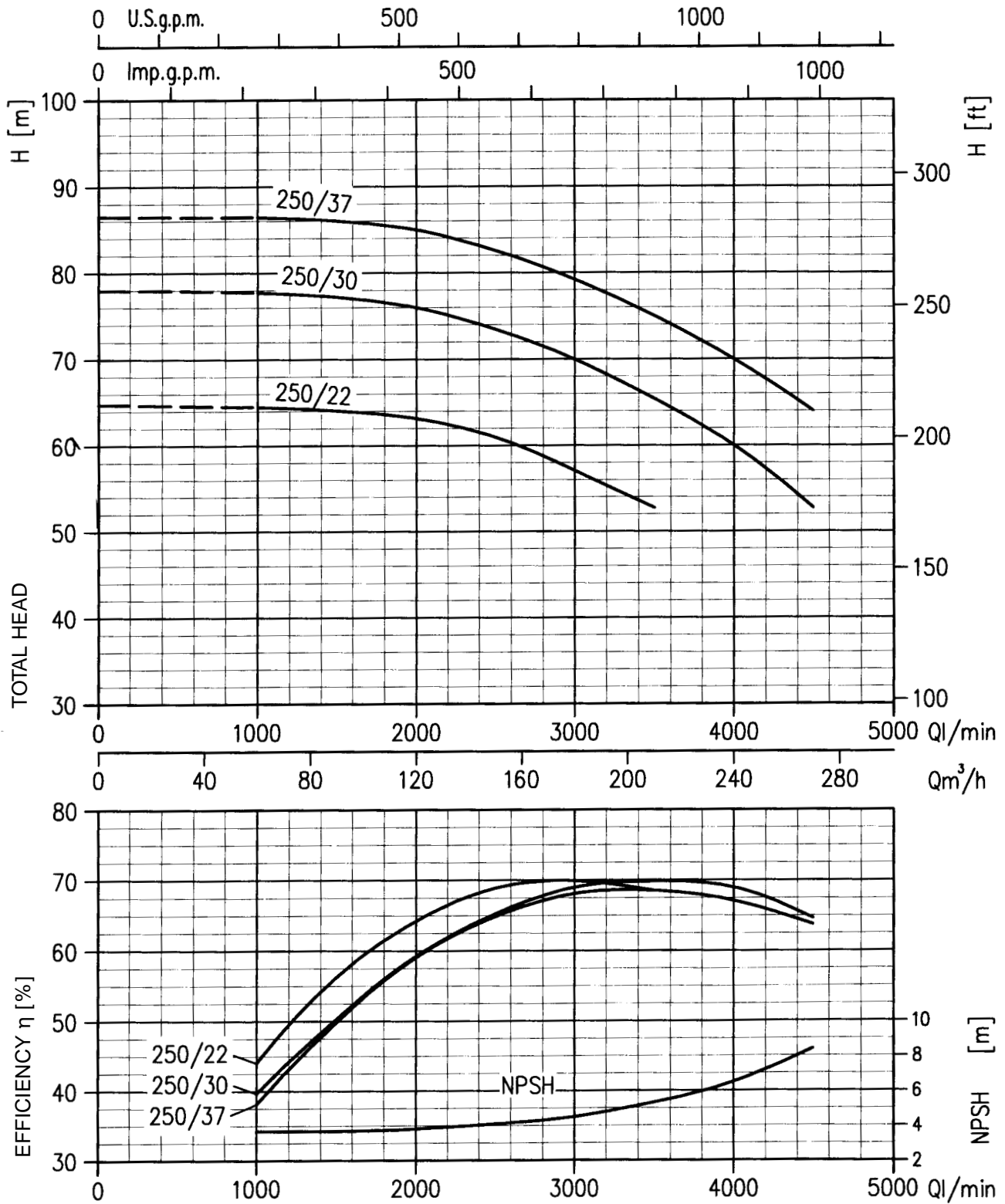

DIMENSIONAL DRAWINGS 2+1GP MD/MMD

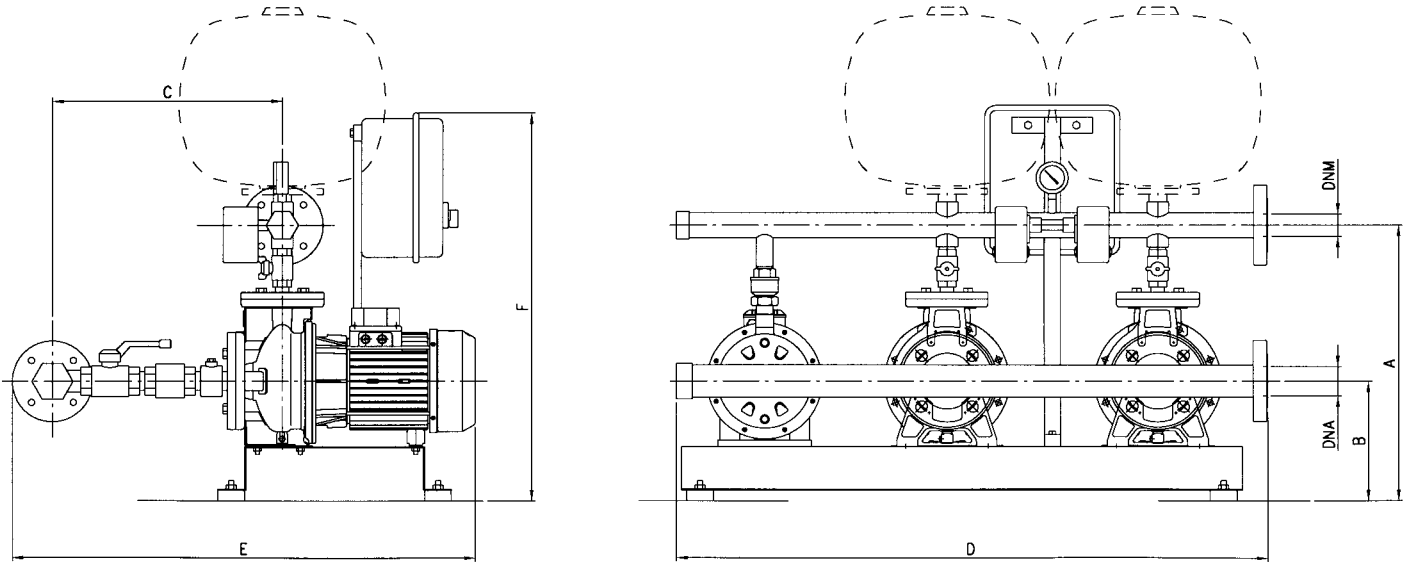

DIMENSIONAL TABLE

Model	Dimensions (mm)								Weight (Kg)
	A	B	C	D	E	F	DNA	DNM	
2+1GP MD 32-160/1.5	600	232	413	1200	878	1000	100	80	208
2+1GP MD 32-160/2.2	600	232	413	1200	878	1000	100	80	214
2+1GP MD 32-200/3	630	260	413	1200	928	1000	100	80	235
2+1GP MD 32-200/4	630	260	413	1200	928	1000	100	80	264
2+1GP MMD 32-250/7.5	695	280	433	1200	1073	1000	100	80	313
2+1GP MMD 32-250/10	695	280	433	1200	1073	1000	100	80	357
2+1GP MMD 32-250/12	695	280	433	1200	1073	1000	100	80	370
2+1GP MD 40-160/3	600	232	433	1200	898	1100	125	100	250
2+1GP MD 40-160/4	600	232	433	1200	898	1100	125	100	280
2+1GP MD 40-200/5.5	630	260	453	1200	988	1100	125	100	324
2+1GP MD 40-200/7.5	630	260	453	1200	1093	1100	125	100	346
2+1GP MMD 40-250/10	695	280	453	1200	1093	1100	125	100	376
2+1GP MMD 40-250/12	695	280	453	1200	1093	1100	125	100	415
2+1GP MMD 40-250/15	695	280	453	1200	1093	1100	125	100	436
2+1GP MD 50-160/5.5	630	260	463	1200	908	1100	150	125	322
2+1GP MD 50-160/7.5	630	260	463	1200	1103	1100	150	125	372
2+1GP MD 50-200/9.2	695	260	463	1200	1103	1100	150	125	387
2+1GP MD 50-200/11	695	260	463	1200	1103	1100	150	125	396
2+1GP MMD 50-250/15	740	280	463	1200	1103	1100	150	125	450
2+1GP MMD 50-250/18.5	740	280	463	1200	1103	1100	150	125	555
2+1GP MMD 50-250/22	740	280	463	1200	1103	1100	150	125	609
2+1GP MD 65-160/11	695	260	473	1500	1113	1200	200	150	412
2+1GP MD 65-160/15	695	260	473	1500	1113	1200	200	150	445
2+1GP MD 65-200/18.5	740	280	473	1500	1273	1200	200	150	568
2+1GP MD 65-200/22	740	280	473	1500	1273	1200	200	150	622
2+1GP MMD 65-250/22	785	300	473	1500	1283	1200	200	150	622
2+1GP MMD 65-250/30	785	300	473	1500	1378	1200	200	150	718
2+1GP MMD 65-250/37	785	300	473	1500	1378	1200	200	150	772

PRESSURE BOOSTER SETS WITH 3 HORIZONTAL SINGLE/TWIN IMPELLER CENTRIFUGAL PUMPS WITH STAINLESS STEEL "CDX-2CDX" SERIES AND CAST IRON "CMB-CDA" SERIES HYDRAULICS



TECHNICAL CHARACTERISTICS

The set base and manifolds are galvanized steel. The delivery manifold can accept a further 3 vertical-type diaphragm tanks. 3 pressure switches, the control panel and a pressure gauge are all positioned on the manifold. Each pump has a suction gate valve, non-return valve and delivery gate valve. Each pump can also be connected to an air feeder. The control panel is held up by a support that is fixed to the base.

CE marked control panel

- Components IMQ and VDE marked.
- Very low voltage auxiliary circuit.
- Motor starting and stopping is controlled by 3 pressure switches.
- Can be connected to floats or low pressure switches to stop operation if there is no supply water.
- Equipped with a device that alternates the lead pump at each start.
- Supply: - three phase 400 V, 50 Hz
- Starting: - direct on line
- Power circuit protection fuses
- Auxiliary circuit protection fuses
- IP 55 protection
- Door interlocked isolator
- Aut. - 0 - man. switches for each pump
- Thermal protection reset
- Pilot LED:
 - mains power
 - pump running
 - level alarm
 - pump being protected
- Special versions of panels can be used upon request

WORKING PRINCIPLE

If there is a water demand while the pumps are stopped, the pressure in the system drops. As a consequence the highest-set pressure switch contact closes, and this causes the first pump to start. If the required flow is greater than the capacity of one pump, the pressure continues to drop until the second pressure switch contact and/or third one closes and one main pump or both start. Stopping or reducing the outgoing flow raises the system pressure, which in turn causes the pressure switch contact to open and allows the pumps to stop in turn. Alternating the starting order of the two pumps reduces the number of hourly starts of the lead pump and balances their running times. Connecting a low level float in the supply tank or a low pressure switch in the system, wired through to the control panel will protect against the most frequent cause of pump failure: dry running.

PERFORMANCE CURVES 3GP CDX-2CDX (according to ISO 9906 grade 2)

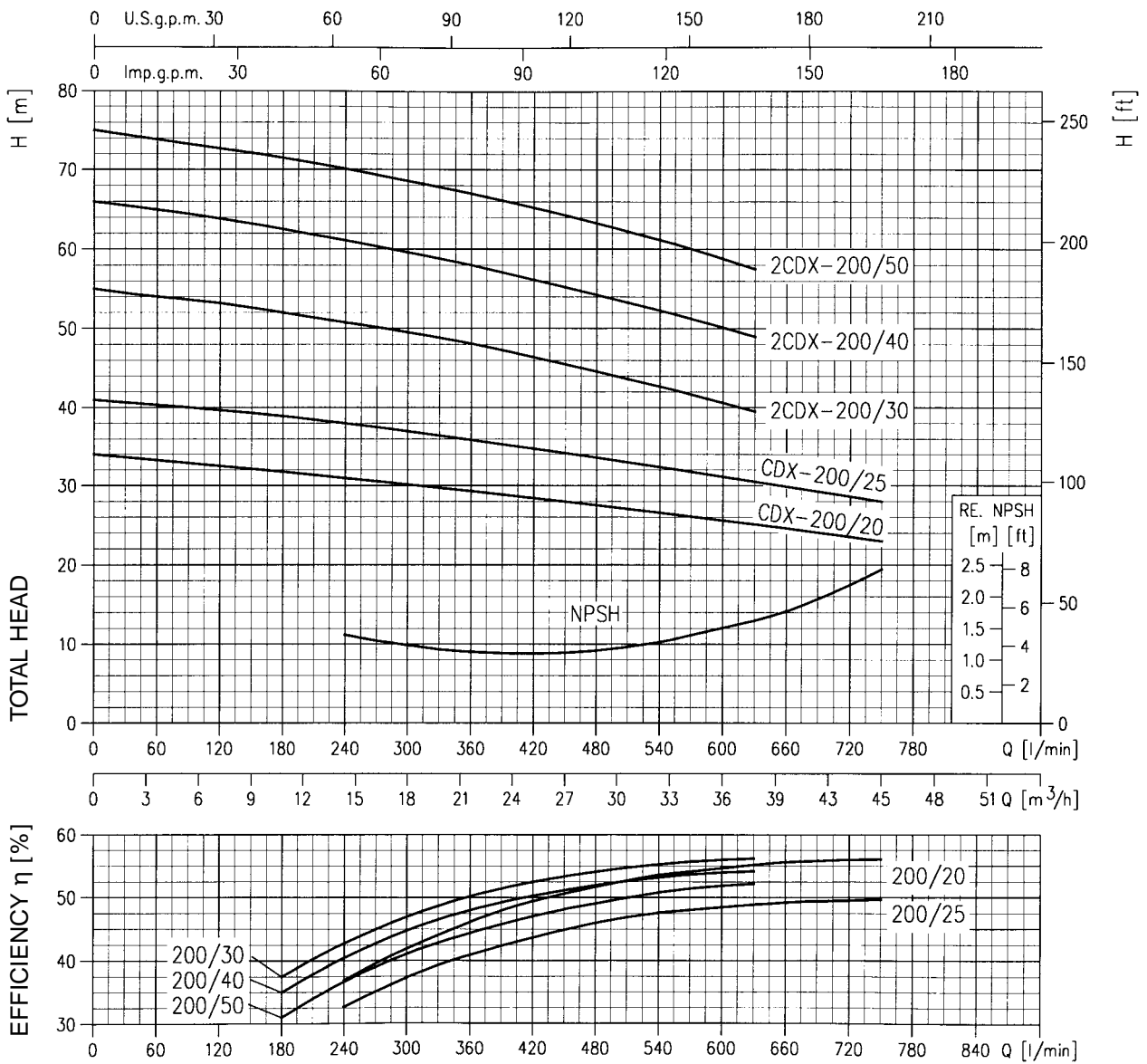

3GP CDX-2CDX-CMB-CDA

PERFORMANCE CURVES 3GP CDA (according to ISO 9906 grade 2)

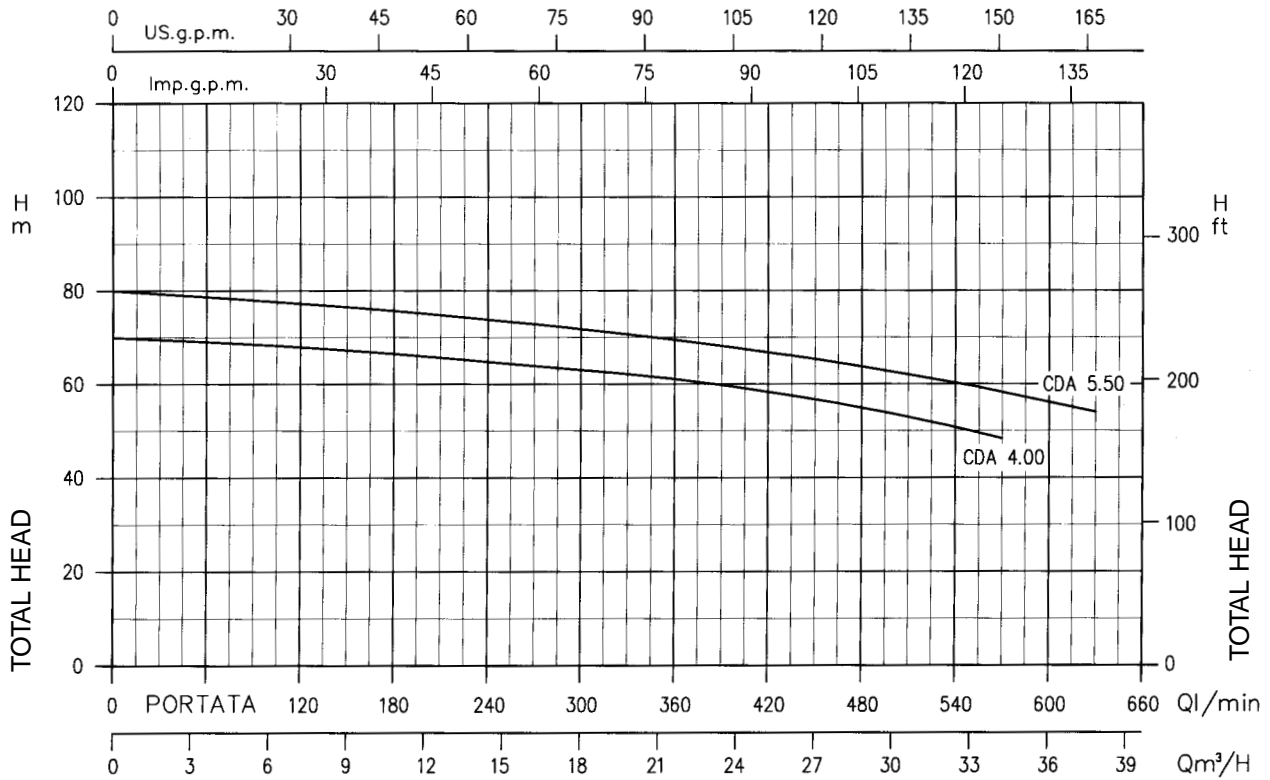

PERFORMANCE CURVES 3GP CMB (according to ISO 9906 grade 2)

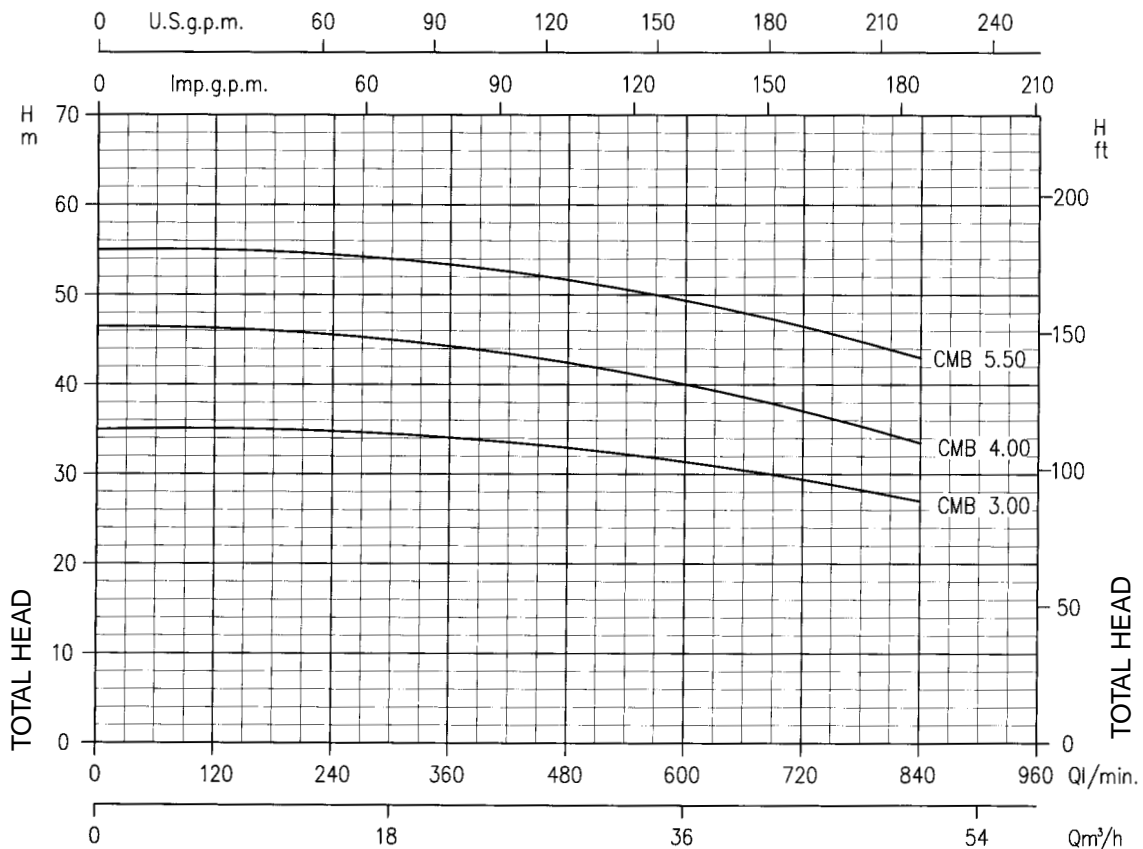

PERFORMANCE TABLE OF THE THREE PUMPS WORKING TOGETHER

Pump type Three phase 400 V	kW	Abs. curr. (A)	Q=Capacity						
			l/min m ³ /h	0	300	450	600	750	840
				H = Total head [m]					
CDX 200/20	1,5+1,5+1,5	12	34	31,5	29,5	27,5	23		
CDX 200/25	1,8+1,8+1,8	14,4	41	37	34,5	32	28		
2CDX 200/30	2,2+2,2+2,2	18	55	49,5	45,5	41			
2CDX 200/40	3+3+3	19,8	66	59,5	55	50,5			
2CDX 200/50	3,7+3,7+3,7	26,1	75	68,5	64	59			
CMB 3,00T	2,2+2,2+2,2	14,4	35	34,5	33,5	31,5	28,8	27	
CMB 4,00T	3+3+3	20,7	46,5	45	43	40	36,2	33,5	
CMB 5,50T	4+4+4	27,6	55	54	52	49,5	45,7	43	
CDA 4,00T	3+3+3	22,5	70	62,5	56				
CDA 5,50T	4+4+4	28,5	80	71,8	65	56			

DIMENSIONAL DRAWINGS

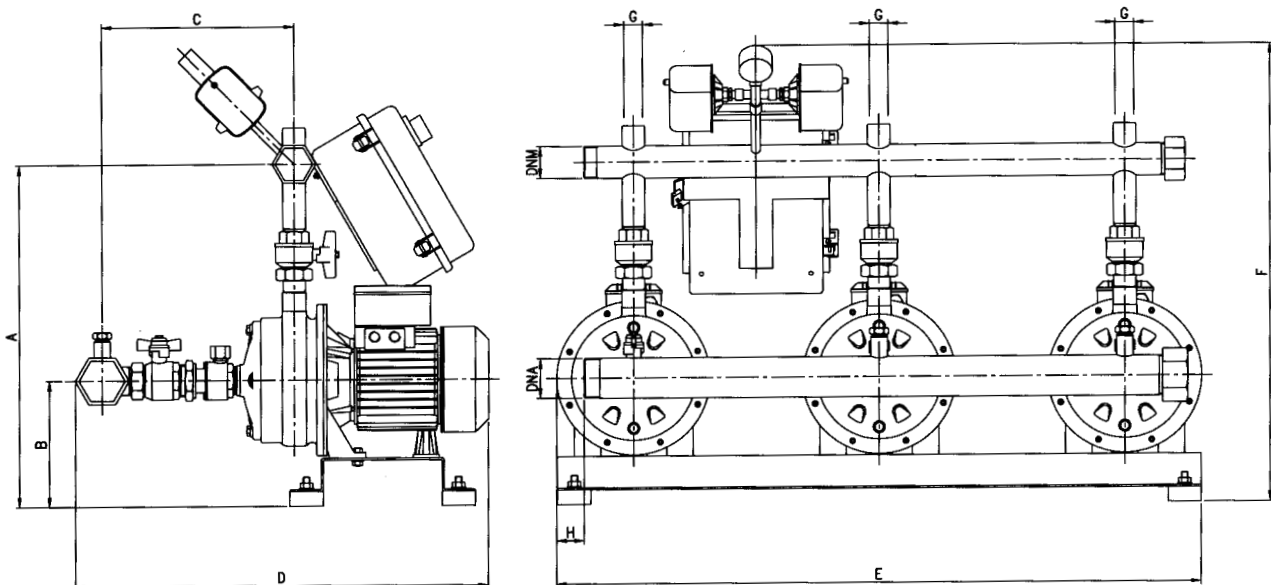

DIMENSIONAL TABLE

Model	Dimensions (mm)										Weight (Kg)
	A	B	C	D	E	F	G	H	DNA	DNM	
3GP CDX 200/20	503	166	306	642	900	686	1" F	40	2 1/2"	2"	104
3GP CDX 200/25	503	166	306	642	900	686	1" F	40	2 1/2"	2"	112
3GP 2CDX 200/30	515	178	340	717	900	698	1" F	40	2 1/2"	2"	136
3GP 2CDX 200/40	535	190	340	717	900	718	1" F	40	2 1/2"	2"	136
3GP 2CDX 200/50	535	190	340	743	900	718	1" F	40	2 1/2"	2"	159
3GP CMB 300	546	184	310	670	900	729	1" F	40	2 1/2"	2"	123
3GP CMB 400	598	206	313	726	900	781	1" F	40	2 1/2"	2"	174
3GP CMB 550	598	206	313	726	900	781	1" F	40	2 1/2"	2"	180
3GP CDA 400	583	206	349	765	900	766	1" F	40	2 1/2"	2"	188
3GP CDA 550	583	206	349	765	900	766	1" F	40	2 1/2"	2"	200

PRESSURE BOOSTER SETS WITH 3 MULTISTAGE VERTICAL PUMPS WITH STAINLESS STEEL HYDRAULICS "EVM" SERIES, OR WITH STAINLESS STEEL HYDRAULICS, CAST IRON BASE CASING COVER "EVM(G)" SERIES - WITH STANDARDISED MOTOR



TECHNICAL CHARACTERISTICS

The set base and manifolds are of galvanized steel. The delivery manifold can accept a further 3 vertical-type diaphragm tanks. 3 pressure switches, the control panel and a pressure gauge are all positioned on the manifold. Each pump has a suction gate valve, non-return valve and delivery gate valve. Each pump can also be connected to an air feeder. The control panel is held up by a support that is fixed to the base.

CE marked control panel

- Components IMQ and VDE marked.
- Very low voltage auxiliary circuit.
- Motor starting and stopping is controlled by 3 pressure switches.
- Can be connected to floats or low pressure switches to stop operation if there is no supply water.
- Equipped with a device that alternates the lead pump at each start.
- Supply:
 - three phase 400 V, 50 Hz
- Starting:
 - direct on line for powers up to 7,5 kW
 - star/triangle for powers above 7,5 kW
- Power circuit protection fuses
- Auxiliary circuit protection fuses
- IP 55 protection
- Door interlocked isolator
- Aut. - 0 - man. switches for each pump
- Thermal protection reset
- Pilot LED:
 - mains power
 - pump running
 - level alarm
 - pump being protected
- Special versions of panels can be used upon request

WORKING PRINCIPLE

If there is a water demand while the pumps are stopped, the pressure in the system drops. As a consequence the highest-set pressure switch contact closes, and this causes the pump to start. If the required flow is greater than the capacity of one pump, the pressure continues to drop until the second pressure switch contact and/or third one closes and one main pumps or both start. Stopping or reducing the outgoing flow raises the system pressure, which in turn causes the pressure switch contact to open and allows the pumps to stop in turn. Alternating the starting order of the two pumps reduces the number of hourly starts of the lead pump and balances their running times. Connecting a low level float in the supply tank or a low pressure switch in the system, wired through to the control panel will protect against the most frequent cause of pump failure: dry running.

PERFORMANCE CURVES 3GP EVM 8 (according to ISO 9906 grade 2)

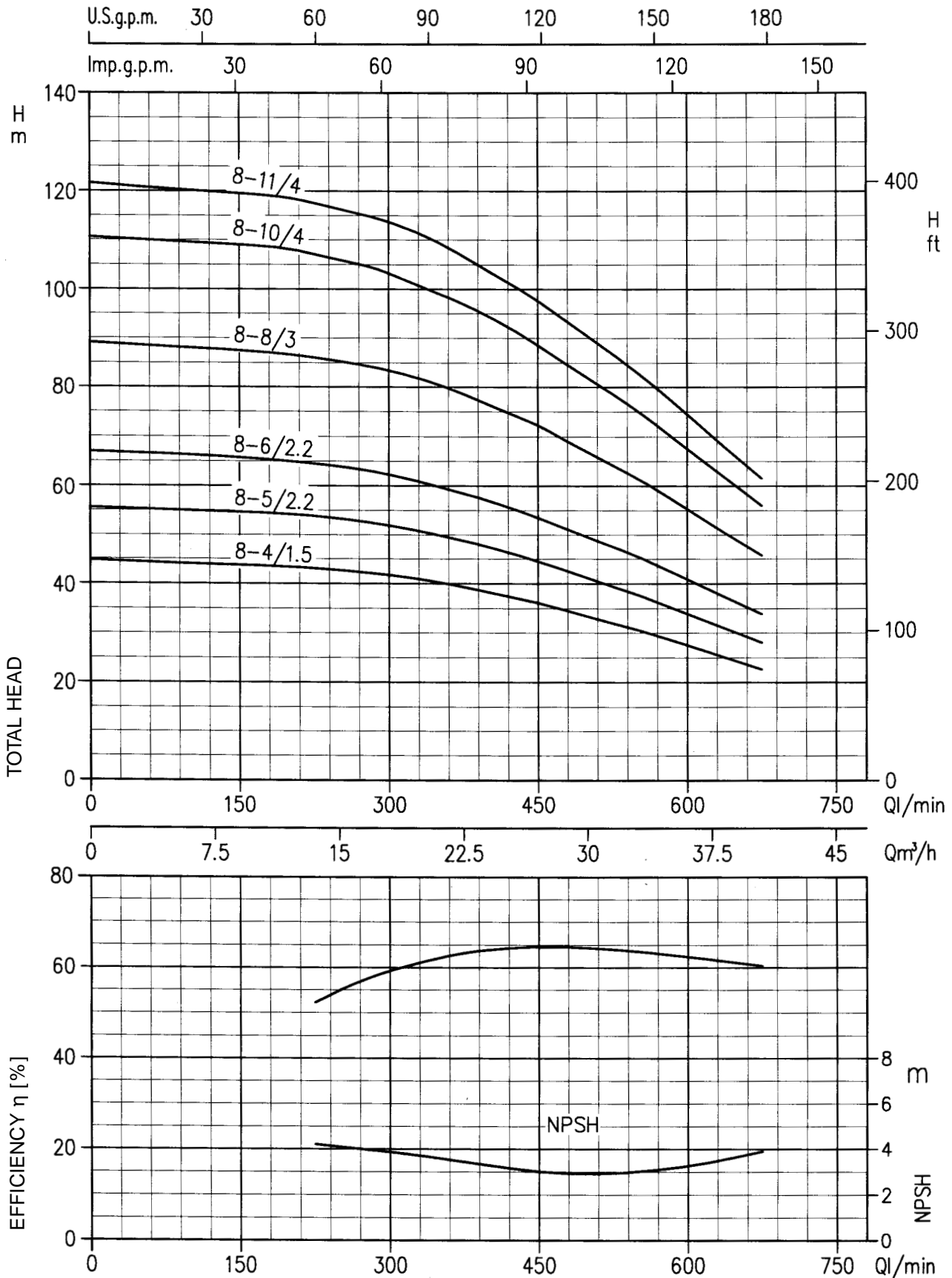

PERFORMANCE CURVES 3GP EVM 16 (according to ISO 9906 grade 2)

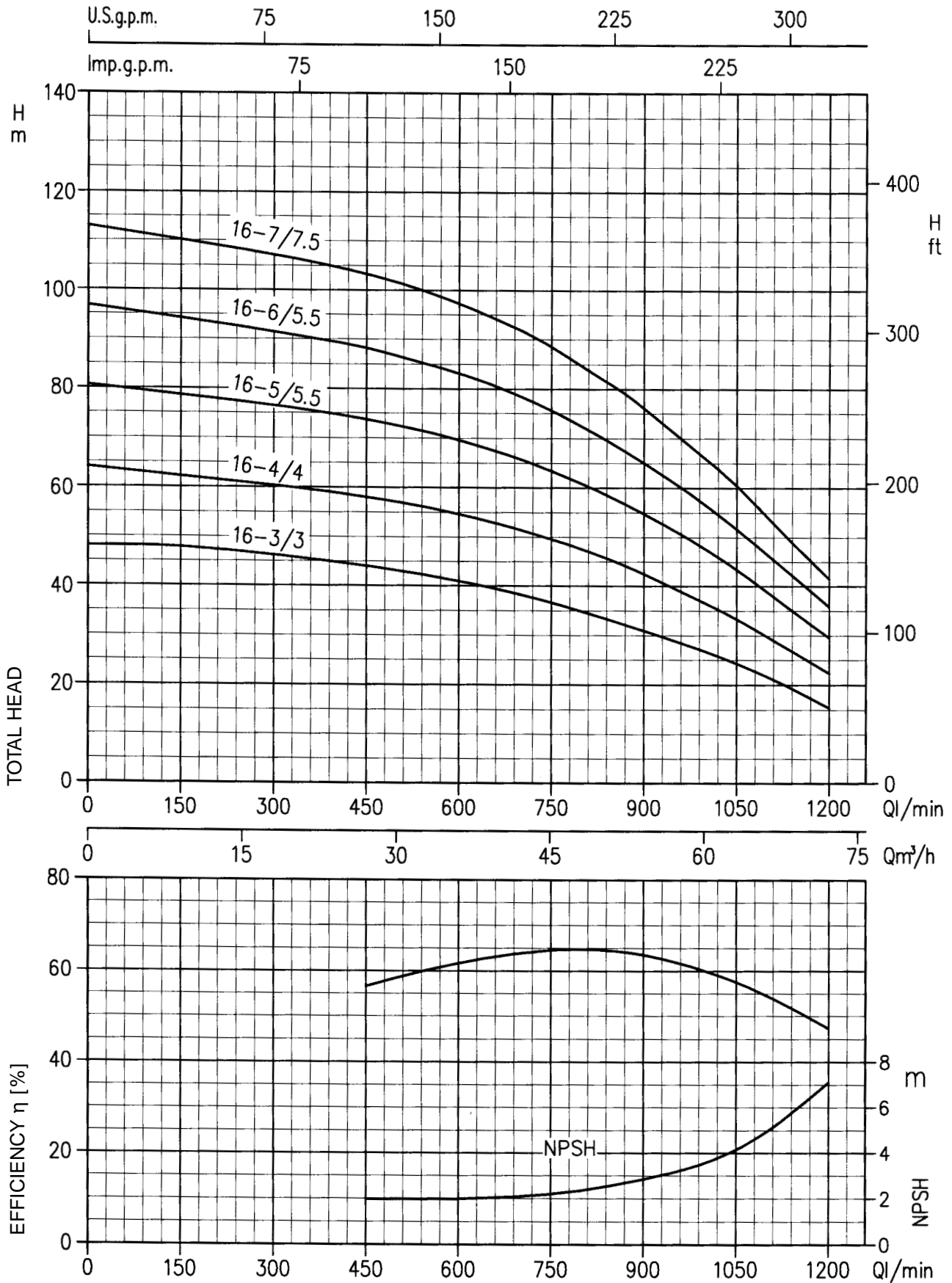

PERFORMANCE CURVES 3GP EVM(G) 30 (according to ISO 9906 grade 2)

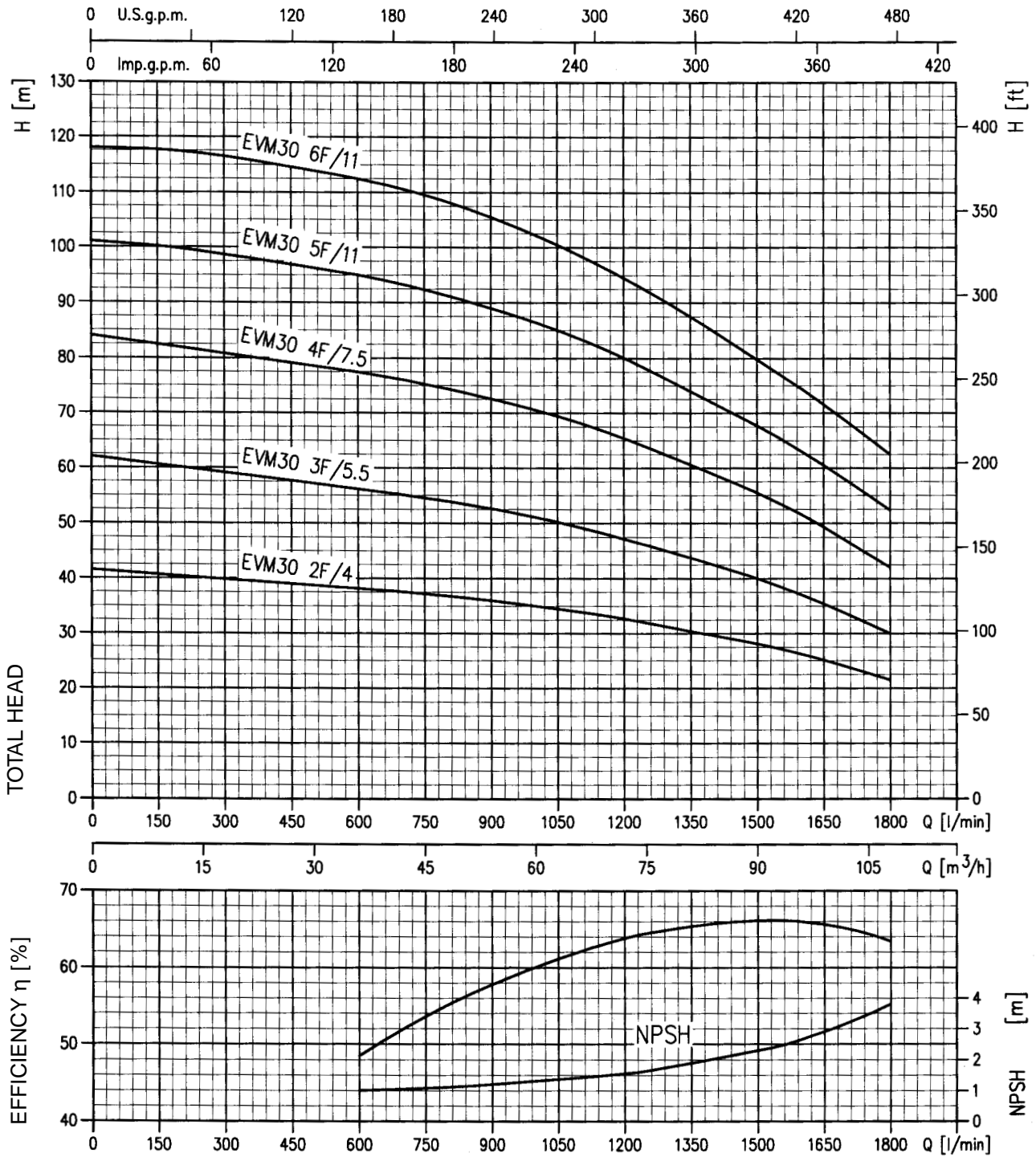

PERFORMANCE CURVES 3GP EVM(G) 60 (according to ISO 9906 grade 2)

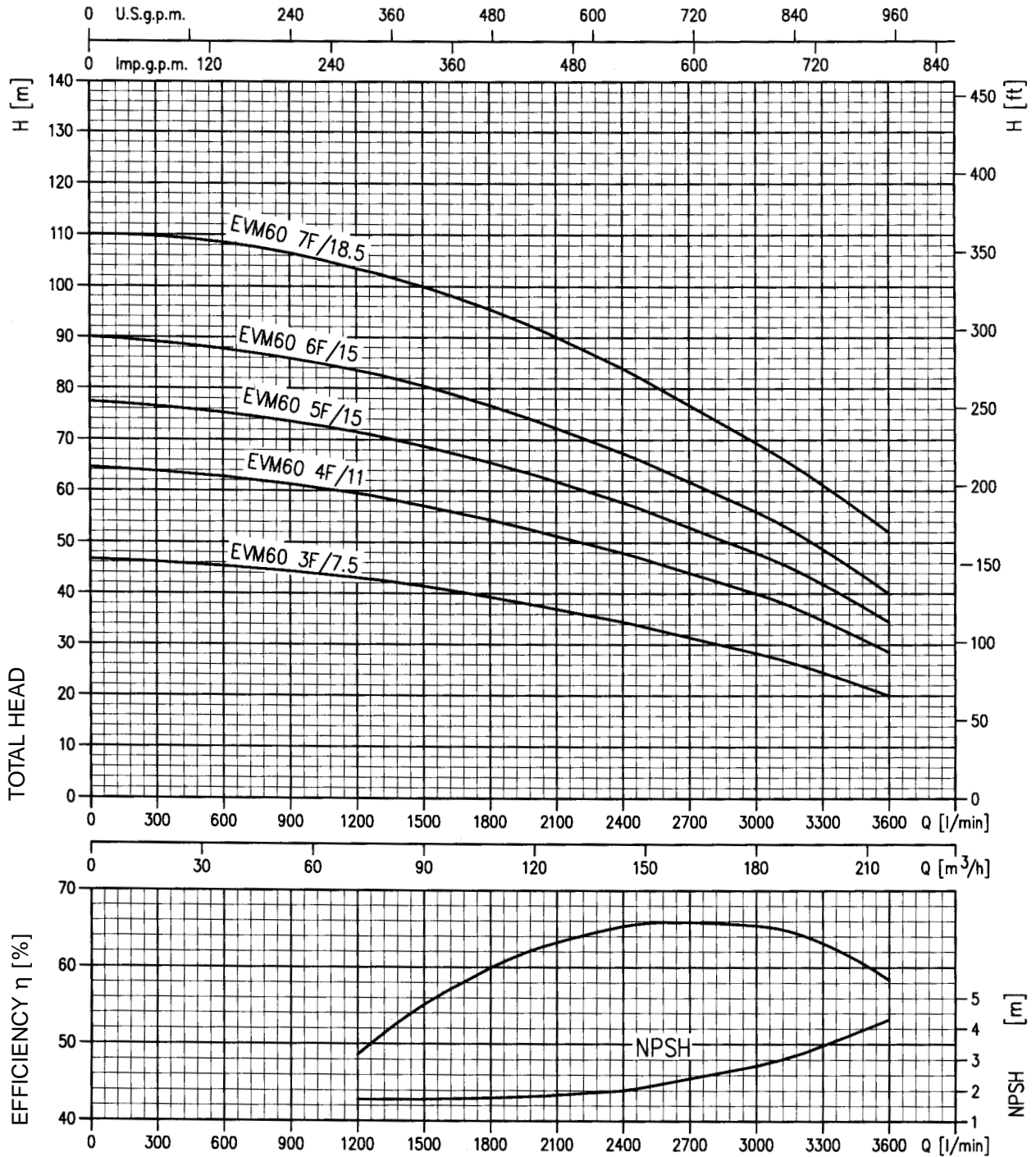

PERFORMANCE TABLE OF THE THREE PUMPS WORKING TOGETHER

Pump type Three phase 400 V	kW	Absorbed current (A)	Q=Capacity														
			l/min	0	240	300	360	450	525	600	675	750	900	1050	1200		
			m³/h	0	14,4	18	21,6	27	31,5	36	40,5	45	54	63	72		
			H=Total head [m]														
EVM8 4N/1,5	1,5 + +1,5 + 1,5	9,9	44,5	42,2	41,8	40,0	36,1	31,5	27,7	22,6							
EVM8 5N/2,2	2,2 + 2,2 + 2,2	13,2	55,5	53,0	51,8	49,1	44,3	40,0	34,0	28,3							
EVM8 6N/2,2	2,2 + 2,2 + 2,2	13,2	67,0	64,2	62,0	59,0	53,6	47,0	40,9	33,8							
EVM8 8N/3	3 + 3 + 3	18,9	89,0	85,0	83,2	80,2	72,5	64,8	55,0	45,8							
EVM8 10N/4	4 + 4 + 4	24,6	111,0	106,0	103,2	98,4	87,8	79,8	67,5	56,5							
EVM8 11N/4	4 + 4 + 4	24,6	122,0	116,2	113,2	108,0	97,8	88,0	74,5	61,4							
EVM16 3F/3	3 + 3 + 3	18,9	48,0				43,6	42,0	40,0	38,1	36,0	30,7	23,8	15,4			
EVM16 4F/4	4 + 4 + 4	24,6	64,0				58,2	56,4	54,4	52,0	49,7	42,3	33,4	22,3			
EVM16 5F/5,5	5,5 + 5,5 + 5,5	34,5	81,0				73,8	71,5	69,0	67,1	63,7	54,9	43,6	29,5			
EVM16 6F/5,5	5,5 + 5,5 + 5,5	34,5	97,0				88,3	85,3	82,2	79,8	75,8	65,0	52,3	35,8			
EVM16 7F/7,5	7,5 + 7,5 + 7,5	45,9	113,0				103,3	99,5	96,0	92,5	88,2	76,5	60,0	41,3			

Pump type Three phase 400 V	kW	Absorbed current (A)	Q=Capacity																
			l/min	0	300	450	600	750	900	999	1200	1350	1500	1650	1800	2100	2400	3000	3600
			m³/h	0	18	27	36	45	54	60	72	81	90	99	108	126	144	160	216
			H=Total head [m]																
EVM(G) 30 2F/4	4 + 4 + 4	24,6	41,5	39,8	39	38,2	37,6	36,0	34,8	32,7	30,4	28,1	25	21,5					
EVM(G) 30 3F/5,5	5,5 + 5,5 + 5,5	34,5	62	59,1	58	56,2	54,0	52,5	50,5	47,2	44,0	40	35,5	30					
EVM(G) 30 4F/7,5	7,5 + 7,5 + 7,5	45,9	84	80,8	79,8	77,4	75,0	72,6	70,0	65,6	61,0	55,5	49	42					
EVM(G) 30 5F/11	11 + 11 + 11	61,2	101	98,7	97,7	95,0	92,0	89,0	86,0	80,1	75,0	67,7	60	52,3					
EVM(G) 30 6F/11	11 + 11 + 11	61,2	118	116,5	115,0	112,6	109,8	105,4	102,5	94,6	87,0	79,8	71,5	62,5					
EVM(G) 60 3F/7,5	7,5 + 7,5 + 7,5	45,9	46,6	49,4						43,0	42	41,5	40,5	39,3	37	34,5	28,3	19,5	
EVM(G) 60 4F/11	11 + 11 + 11	61,2	64,5							59,5	58	57	56	54,4	52	48	40	28,5	
EVM(G) 60 5F/15	15 + 15 + 15	82,8	77,3							71,5	70	68,5	67	65,6	62,3	57,8	48	34,3	
EVM(G) 60 6F/15	15 + 15 + 15	82,8	90							83,5	82	80	78	76,7	73	67,5	56	40	
EVM(G) 60 7F/18,5	18,5 + 18,5 + 18,5	96	110							103,5	102	100	97,5	95,5	90	84	69,5	52	

DIMENSIONAL DRAWINGS 3GP EVM(G)

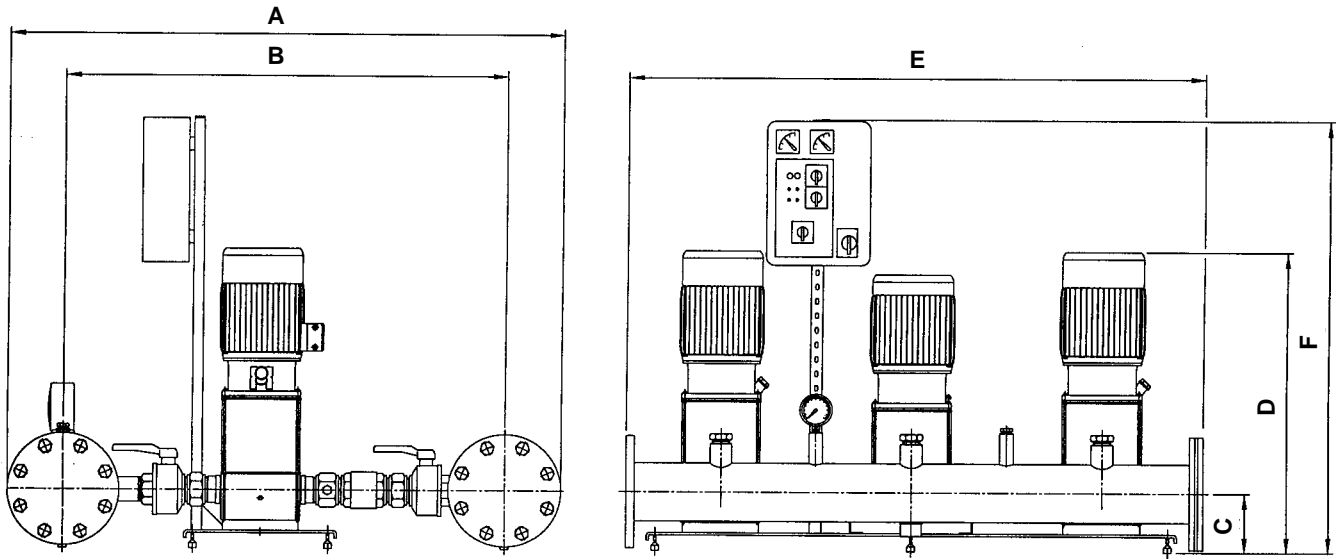

DIMENSIONAL TABLE

Model	Dimensions (mm)							
	A	B	C	D	E	F	DNA	DNM
3GP EVM2 4N/0.55	720	651	125	528	1030	880	80	80
3GP EVM2 5N/0.55	720	651	125	543	1030	880	80	80
3GP EVM2 6N/0.75	720	651	125	610	1030	880	80	80
3GP EVM2 7N/0.75	720	651	125	631	1030	880	80	80
3GP EVM2 9N/1.1	720	651	125	673	1030	880	80	80
3GP EVM2 11N/1.1	720	651	125	715	1030	880	80	80
3GP EVM4 5N/1.1	720	651	125	623	1030	880	80	80
3GP EVM4 6N/1.1	720	651	125	651	1030	880	80	80
3GP EVM4 7N/1.5	720	651	125	693	1030	880	80	80
3GP EVM4 8N/1.5	720	651	125	721	1030	880	80	80
3GP EVM4 10N/2.2	720	651	125	804	1030	880	80	80
3GP EVM4 11N/2.2	720	651	125	832	1030	880	80	80
3GP EVM4 12N/2.2	720	651	125	915	1030	1000	80	80
3GP EVM8 4N/1.5	862	762	155	690	1030	1000	100	100
3GP EVM8 5N/2.2	862	762	155	747	1030	1000	100	100
3GP EVM8 6N/2.2	862	762	155	777	1030	1000	100	100
3GP EVM8 8N/3	862	762	155	892	1030	1000	100	100
3GP EVM8 10N/3	862	762	155	982	1030	1000	100	100
3GP EVM8 11N/4	862	762	155	1012	1030	1000	100	100
3GP EVM16 3F/3	1184	964	165	782	1500	1000	125	125
3GP EVM16 4F/4	1184	964	165	822	1500	1000	125	125
3GP EVM16 5F/5.5	1184	964	165	942	1500	1000	125	125
3GP EVM16 6F/5.5	1184	964	165	982	1500	1000	125	125
3GP EVM16 7F/7.5	1184	964	165	1022	1500	1000	125	125
3GP EVM(G)30 2F/4	1650	1500	205	903	1800	1800	150	150
3GP EVM(G)30 3F/5.5	1650	1500	205	1038	1800	1800	150	150
3GP EVM(G)30 4F/7.5	1650	1500	205	1086	1800	1800	150	150
3GP EVM(G)30 5F/11	1650	1500	205	1290	1800	1800	150	150
3GP EVM(G)30 6F/11	1650	1500	205	1338	1800	1800	150	150
3GP EVM(G)60 3F/7.5	1890	1690	240	1163	1800	1800	200	200
3GP EVM(G)60 4F/11	1890	1690	240	1390	1800	1800	200	200
3GP EVM(G)60 5F/15	1890	1690	240	1462	1800	1800	200	200
3GP EVM(G)60 6F/15	1890	1690	240	1534	1800	1800	200	200
3GP EVM(G)60 7F/18.5	1890	1690	240	1606	1800	1800	200	200

PRESSURE BOOSTER SETS WITH 3 "MD/MMD" SERIES HORIZONTAL MONO-BLOCK PUMPS DERIVED EN 733 (ex DIN 24255) WITH STAINLESS STEEL HYDRAULICS "3M" SERIES AND WITH CAST IRON HYDRAULICS "MD/MMD" SERIES



TECHNICAL CHARACTERISTICS

The set base and manifolds are of galvanized steel. The delivery manifold can accept a further 3 vertical-type diaphragm tanks. 3 pressure switches, the control panel and a pressure gauge are all positioned on the manifold. Each pump has a suction gate valve, non-return valve and delivery gate valve. Each pump can also be connected to an air feeder. The control panel is held up by a support that is fixed to the base.

CE marked control panel

- Components IMQ and VDE marked.
- Very low voltage auxiliary circuit.
- Motor starting and stopping is controlled by 3 pressure switches.
- Can be connected to floats or low pressure switches to stop operation if there is no supply water.
- Equipped with a device that alternates the lead pump at each start.
- Supply:
 - three phase 400 V, 50 Hz
- Starting:
 - direct on line for powers up to 7,5 kW
 - star/triangle for powers above 7,5 kW
- Power circuit protection fuses
- Auxiliary circuit protection fuses
- IP 55 protection
- Door interlocked isolator
- Aut. - 0 - man. switches for each pump
- Thermal protection reset
- Pilot LED:
 - mains power
 - pump running
 - level alarm
 - pump being protected (only for three phase version)
- Special versions of panels can be used upon request

WORKING PRINCIPLE

If there is a water demand while the pumps are stopped, the pressure in the system drops. As a consequence the highest-set pressure switch contact closes, and this causes the pump to start. If the required flow is greater than the capacity of one pump, the pressure continues to drop until the second pressure switch contact and/or third one closes and one main pumps or both start. Stopping or reducing the outgoing flow raises the system pressure, which in turn causes the pressure switch contact to open and allows the pumps to stop in turn. Alternating the starting order of the two pumps reduces the number of hourly starts of the lead pump and balances their running times. Connecting a low level float in the supply tank or a low pressure switch in the system, wired through to the control panel will protect against the most frequent cause of pump failure: dry running.

PERFORMANCE CURVES 3GP 3M (according to ISO 9906 grade 2)

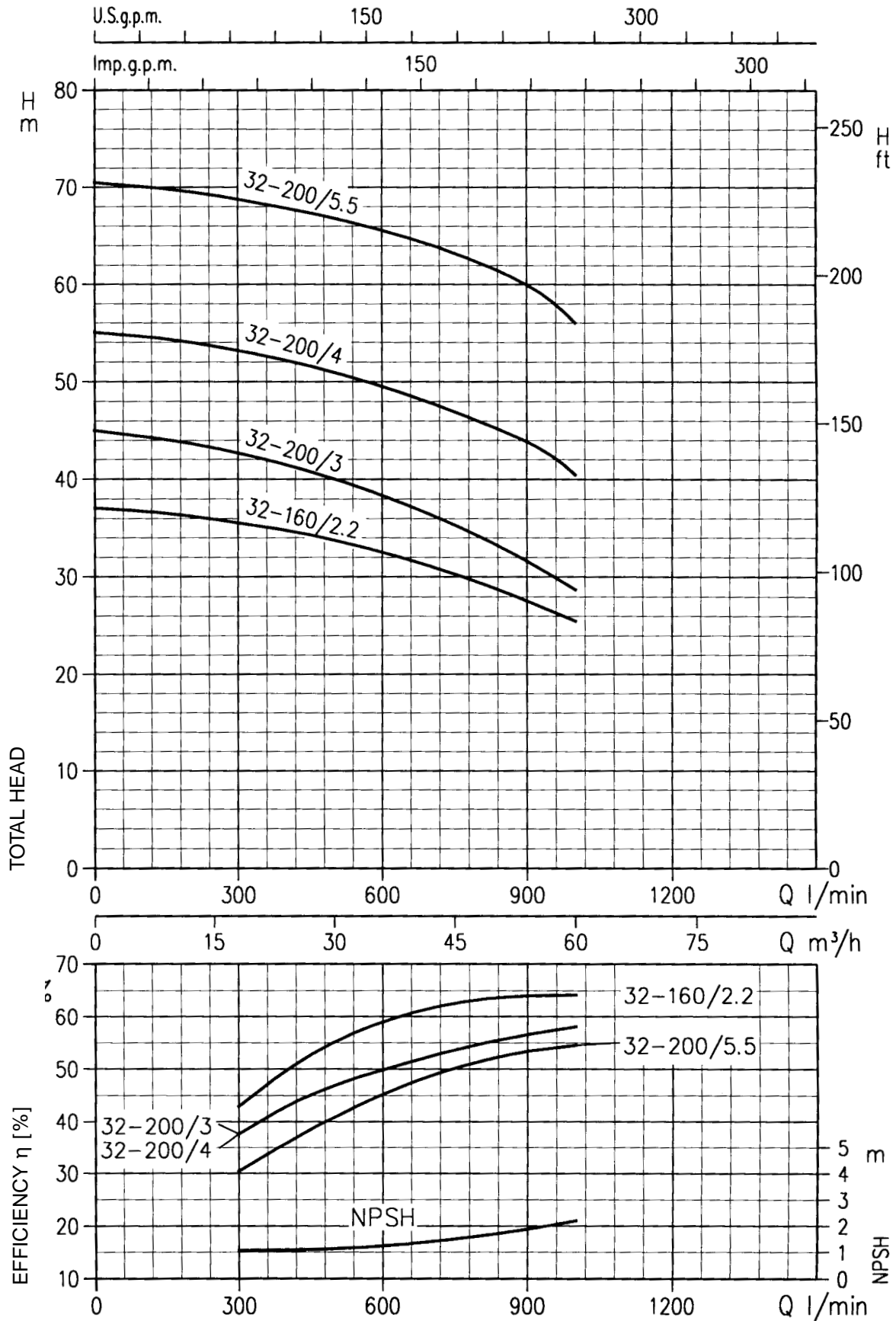

PERFORMANCE CURVES 3GP MD (according to ISO 9906 grade 2)

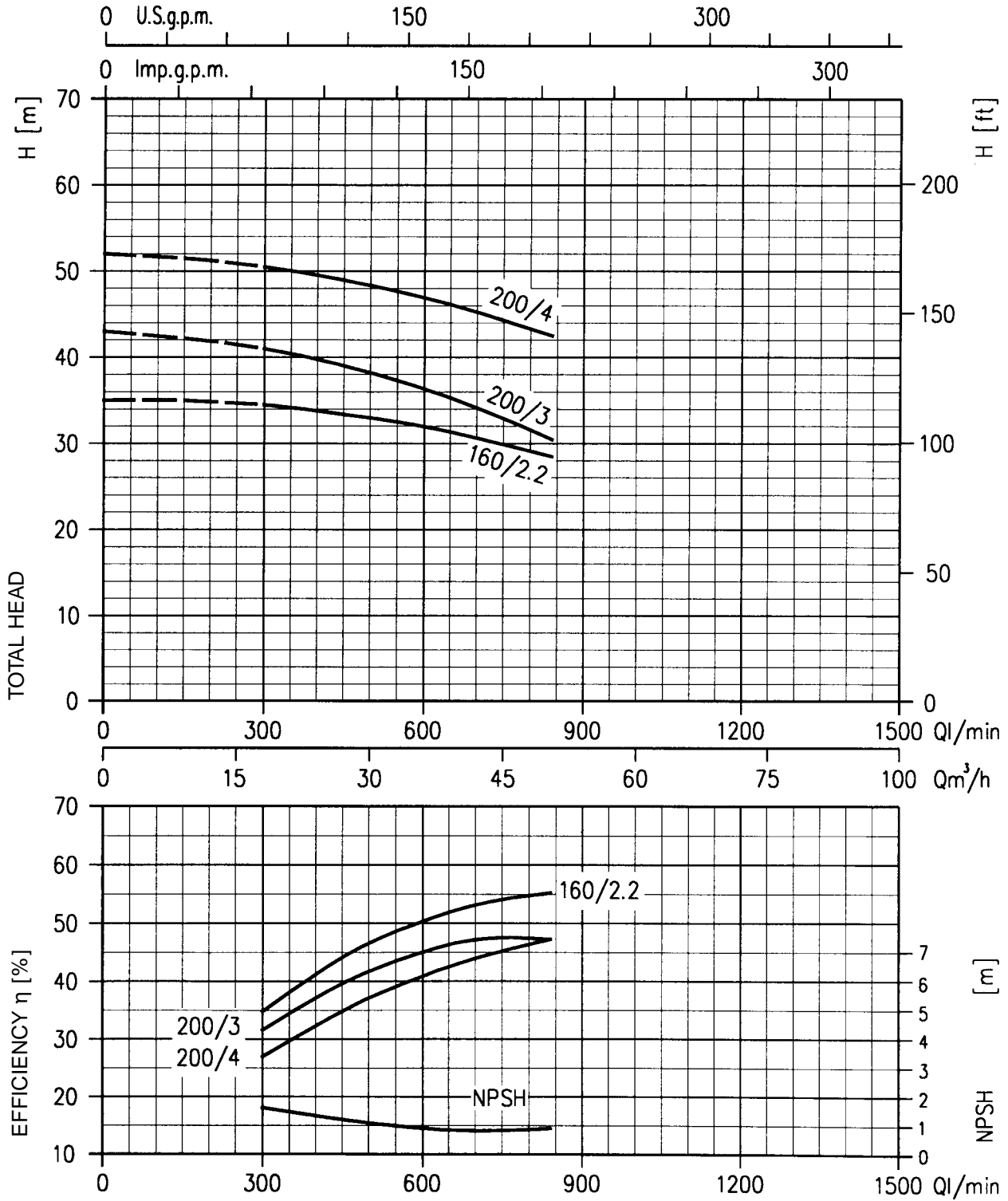

PERFORMANCE CURVES 3GP MMD (according to ISO 9906 grade 2)

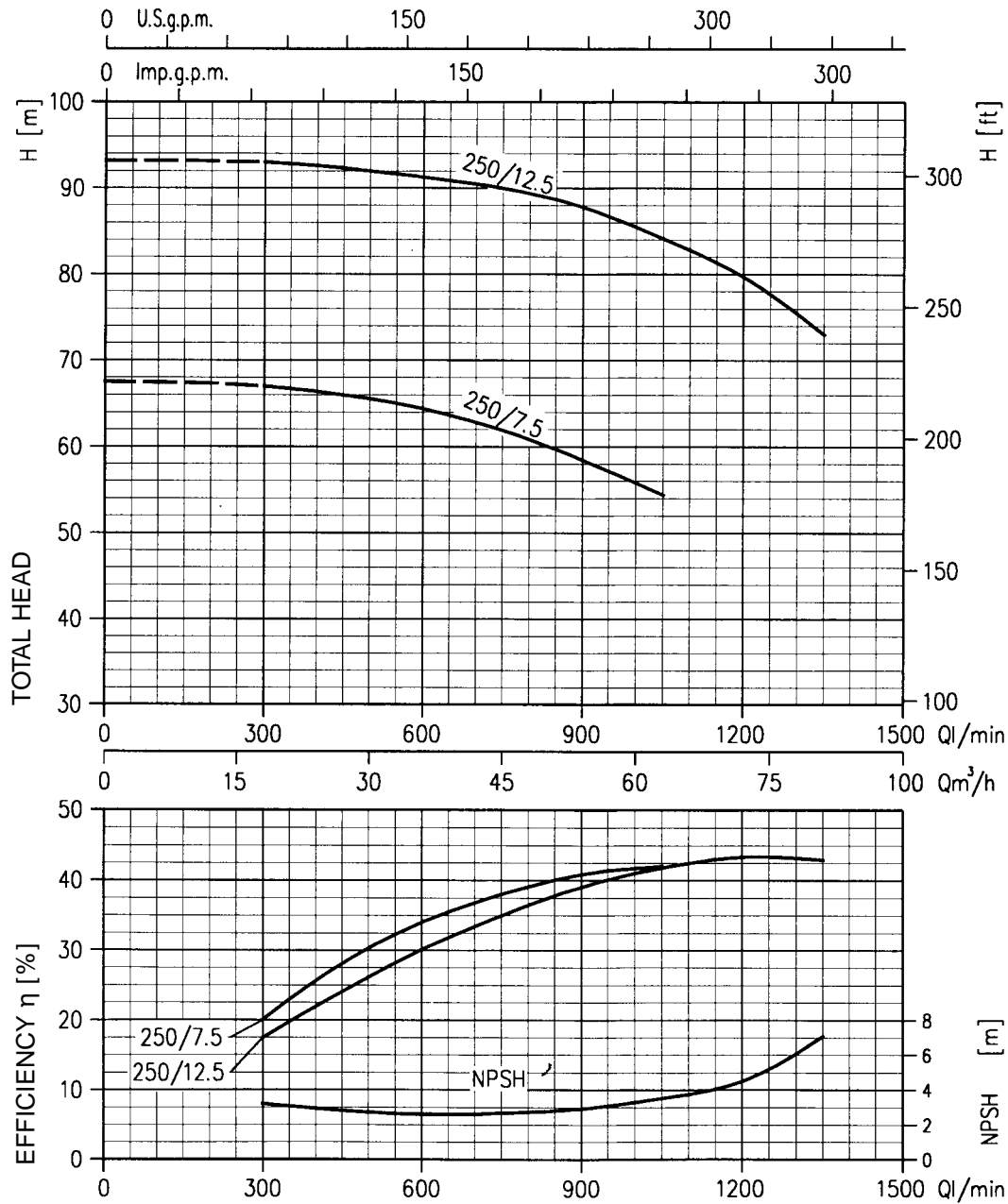

PERFORMANCE TABLE OF THE THREE PUMPS WORKING TOGETHER

Pump type	kW	Abs. curr. (A)	l/min m³/h	Q=Capacity									
				0	300	450	600	750	840	900	999	1200	
Three phase 400 V				0	18	27	36	45	50,4	54	60	60	72
				H=Total head [m]									
3M 32-160/2,2	2,2+2,2+2,2	14,4		37	35,5	34,5	32,5	30,5	29	27,5	25,5	-	-
3M 32-200/3	3+3+3	20,4		45	42,5	41	38,5	35	33,5	31,5	29	-	-
3M 32-200/4	4+4+4	27		55	53	51,5	49,5	47	45,5	43,5	40,5	-	-
3M 32-200/5,5	5,5+5,5+5,5	35,4		70,5	69	67,6	65,5	63	61,8	60	56	-	-
MD 32-160/2,2	2,2+2,2+2,2	15		35	34,5	34	32	30	28,5	-	-	-	-
MD 32-200/3	3+3+3	7		43	41	39	36,3	32,9	30,5	-	-	-	-
MD 32-200/4	4+4+4	27,6		52	50,5	49	46,9	44,3	42,5	-	-	-	-
MMD 32-250/7,5	7,5+7,5+7,5	51,9		67,5	67	66	64	61,5	60	58	56	-	-
MMD 32-250/10	10+10+10	67,5		82,5	82	81	80	78	76,5	75	73	66	66
MMD 32-250/12,5	12,5+12,5+12,5	81		93,5	93	92	91	90	89	88	86,5	80	80

DIMENSIONAL DRAWINGS 3GP 3M-MD/MMD

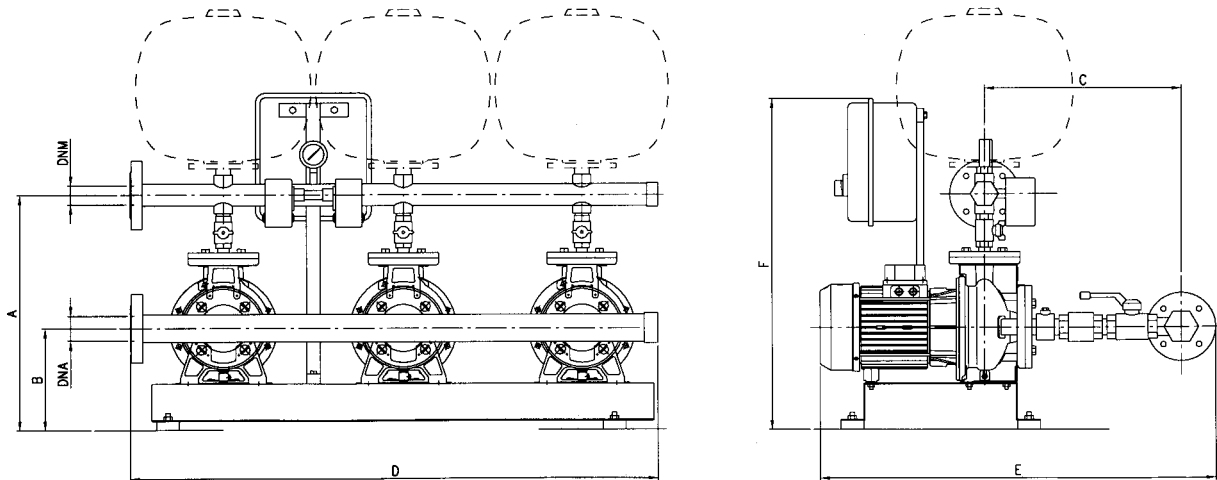

DIMENSIONAL TABLE

Model	Dimensions (mm)							
	A	B	C	D	E	F	DNA	DNM
3GP-3M 32-200/3	542	280	313	710	800	1429	80	80
3GP-3M 32-200/4	542	280	313	710	800	1429	80	80
3GP-3M 32-200/5,5	542	280	313	710	800	1429	80	80
3GP-3M 40-200/5,5	646	280	359	779	800	1437	100	100
3GP-3M 40-200/7,5	646	280	359	779	800	1437	100	100
3GP-3M 40-200/11	646	280	359	779	800	1437	100	100
3GP-3M 40-200/9,2	752	280	483	965	800	1674	150	150
3GP-3M 50-200/11	691	280	483	965	800	1674	150	150
3GP-3M 50-200/15	752	280	483	965	800	1674	150	150

Model	Dimensions (mm)								Weight (Kg)
	A	B	C	D	E	F	DNA	DNM	
3GP-MD 32-160/1.5	600	232	413	1200	878	1000	100	80	208
3GP-MD 32-160/2.2	600	232	413	1200	878	1000	100	80	214
3GP-MD 32-200/3	630	260	413	1200	928	1000	100	80	235
3GP-MD 32-200/4	630	260	413	1200	928	1000	100	80	264
3GP-MMD 32-250/7.5	695	280	433	1200	1073	1000	100	80	313
3GP-MMD 32-250/10	695	280	433	1200	1073	1000	100	80	357
3GP-MMD 32-250/12.5	695	280	433	1200	1073	1000	100	80	370
3GP-MD 40-160/3	600	232	433	1200	898	1100	125	100	250
3GP-MD 40-160/4	600	232	433	1200	898	1100	125	100	280
3GP-MD 40-200/5.5	630	260	453	1200	988	1100	125	100	324
3GP-MD 40-200/7.5	630	260	453	1200	1093	1100	125	100	346
3GP-MMD 40-250/10	695	280	453	1200	1093	1100	125	100	376
3GP-MMD 40-250/12.5	695	280	453	1200	1093	1100	125	100	415
3GP-MMD 40-250/15	695	280	453	1200	1093	1100	125	100	436
3GP-MD 50-160/5.5	630	260	463	1200	908	1100	150	125	322
3GP-MD 50-160/7.5	630	260	463	1200	1103	1100	150	125	372
3GP-MD 50-200/9.2	695	260	463	1200	1103	1100	150	125	387
3GP-MD 50-200/11	695	260	463	1200	1103	1100	150	125	396
3GP-MMD 50-250/15	740	280	463	1200	1103	1100	150	125	450
3GP-MMD 50-250/18.5	740	280	463	1200	1103	1100	150	125	555
3GP-MMD 50-250/22	740	280	463	1200	1103	1100	150	125	609
3GP-MD 65-160/11	695	260	473	1500	1113	1200	200	150	412
3GP-MD 65-160/15	695	260	473	1500	1113	1200	200	150	445
3GP-MD 65-200/18.5	740	280	473	1500	1273	1200	200	150	568
3GP-MD 65-200/22	740	280	473	1500	1273	1200	200	150	622
3GP-MMD 65-250/22	785	300	473	1500	1283	1200	200	150	622
3GP-MMD 65-250/30	785	300	473	1500	1378	1200	200	150	718
3GP-MMD 65-250/37	785	300	473	1500	1378	1200	200	150	772

PRESSURE BOOSTER SETS EQUIPPED WITH INVERTER SPEED CONTROL



The **GPE** set was designed to work with the lead pump controlled by a VLT frequency converter (INVERTER) and the other(s) by fixed speed on/off pumps. With the set configured this way it is possible to maintain a constant system pressure. When the system pressure changes, the pump controlled via Inverter varies its speed, thereby maintaining the required system pressure within the operational parameters. Should the demand exceed the capacity of the lead pump, the second pump will cut in at full speed, then the lead pump speed will control the pressure. When demand ceases, the pump controlled by the inverter reaches minimum speed and will stop after a short period thereby saving energy.

TECHNICAL CHARACTERISTICS

The Micro processor control unit fitted to the GPE sets is standard for booster sets with 1 to 4 pumps, but can be extended to control up to 6 pumps if required. Pump number one is controlled at variable speed and the other pumps start automatically as and when required. This arrangement of pumps and controls reduce running costs and allow for smaller pressure vessels.

The above booster sets configuration is now commonly used within the following:

- General Water supply i.e. Schools, Hotels, Hospitals, high-rise buildings etc
- Industrial Water supply.
- Irrigation systems for gardens, parks, golf courses etc.

Operating principles:

- Booster Set with just pressure switch control relies on feed back from each individual pump pressure switch. Due to the operating principle of the pressure switch there can be a variation in the system pressure of up to 1 bar.
- Booster Set with inverter control responds to the signal from a pressure transducer and subsequently controls the speed of the lead pump. Thereby maintaining a constant system pressure.
- Pump operation in AUTOMATIC, MANUAL or pump ISOLATED.
- Pump motor protection against overload, phase imbalance, high and low voltage protection.
- Dry running protection.
- Inverter protected against phase, imbalance, high and low voltage protection, earth leakage, overheating
- Operation of lead pump by inverter; automatic starting of the other pumps by electromechanical contactor.
- Automatic operation changeover of lead pump (and indeed any other pumps) by electromechanical contactor and pressure switches in the event of an inverter fault.

- Automatic changeover every 24 hours (sequential operation) from the pump starting order, via electromechanical contactor.

Display:

- Volt Meter & Ammeter fitted
- LCD display indicating booster set pressure, number of pumps in operation, system pressure, speed of inverter controlled pump, transducer fault indication
- Indication lamp for power to aux. circuits.
- Indication lamp for power to pumps
- Indication lamp for Inverter and pumps with a fault.
- Indication lamp for low water

Output signals:

- Pumps via pressure switch.
- System pressure by means of a transducer.
- Remote signal for inverter fault and low water indication.

Technical data:

- Supply voltage: 400 V \pm 10% - 3 phase - Frequency: 50-60 Hz
- 1 to 4 pumps as standard (up to six pumps upon request).
- Power for each motor: standard supply from 0.75 to 30 kW (larger sizes on request).
- Type of starting: with electromechanical contacts by direct starting (DOL) and star/delta starting.
- Working limits: -10 +40°C.
- Protection level: IP 55
- Manufactured to the following standards EN 60204-1, EN 60439-1, applied EMCs EN 50081-1, EN 560082-2 for civil and light industrial use.

PERFORMANCE CURVES 2GPE EVM 2 (according to ISO 9906 grade 2)

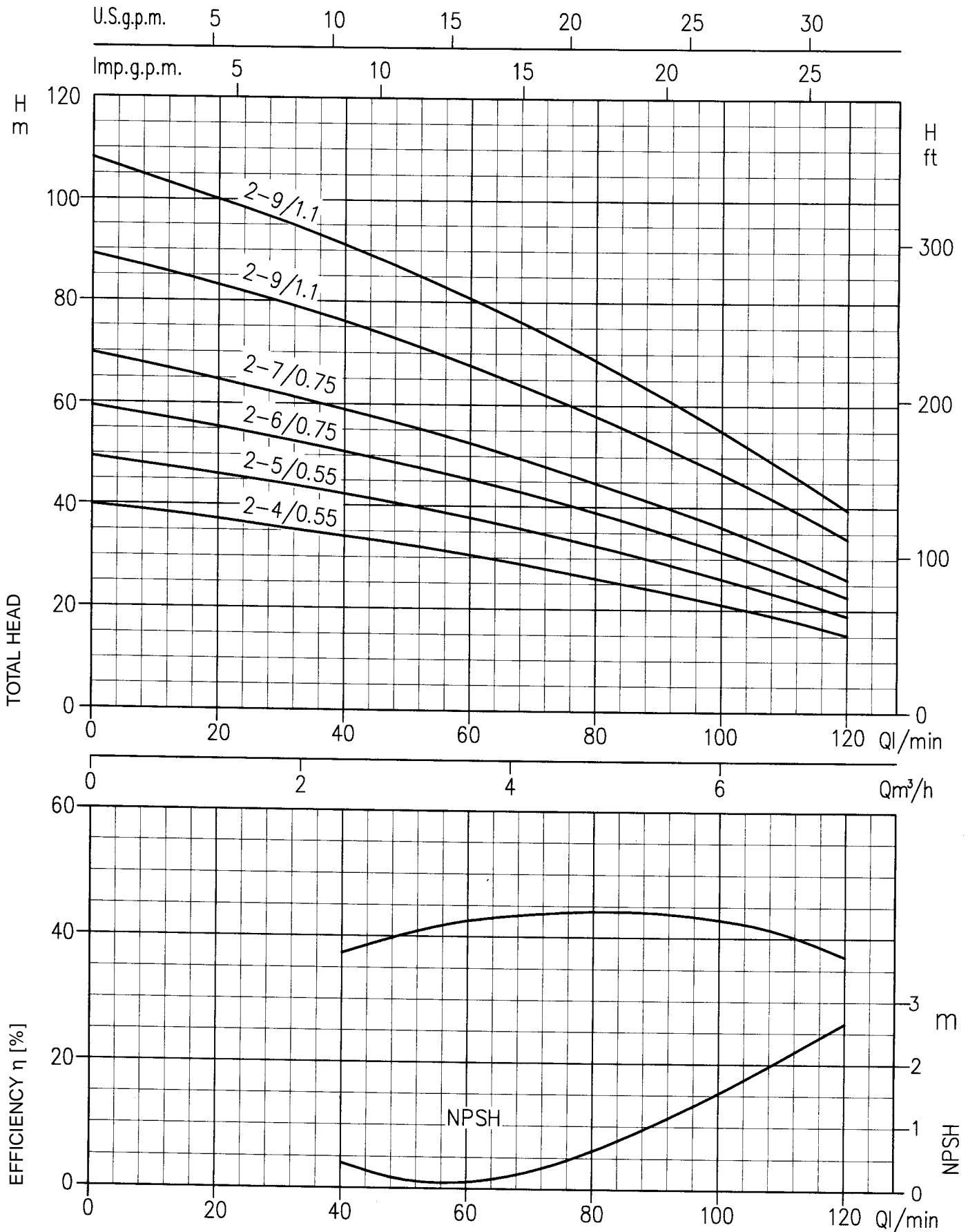

PERFORMANCE CURVES 2GPE EVM 4 (according to ISO 9906 grade 2)

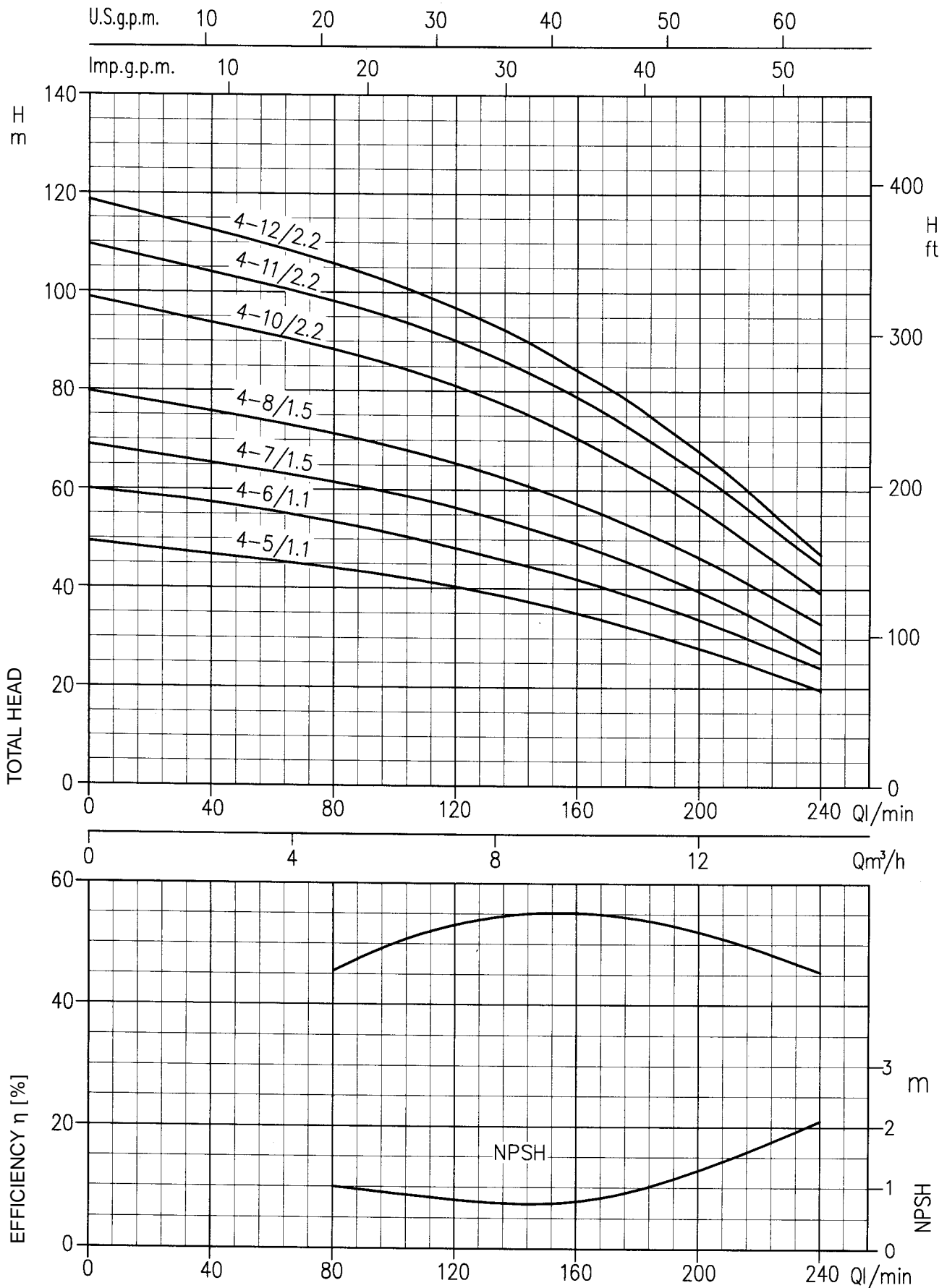

PERFORMANCE CURVES 2GPE EVM 8 (according to ISO 9906 grade 2)

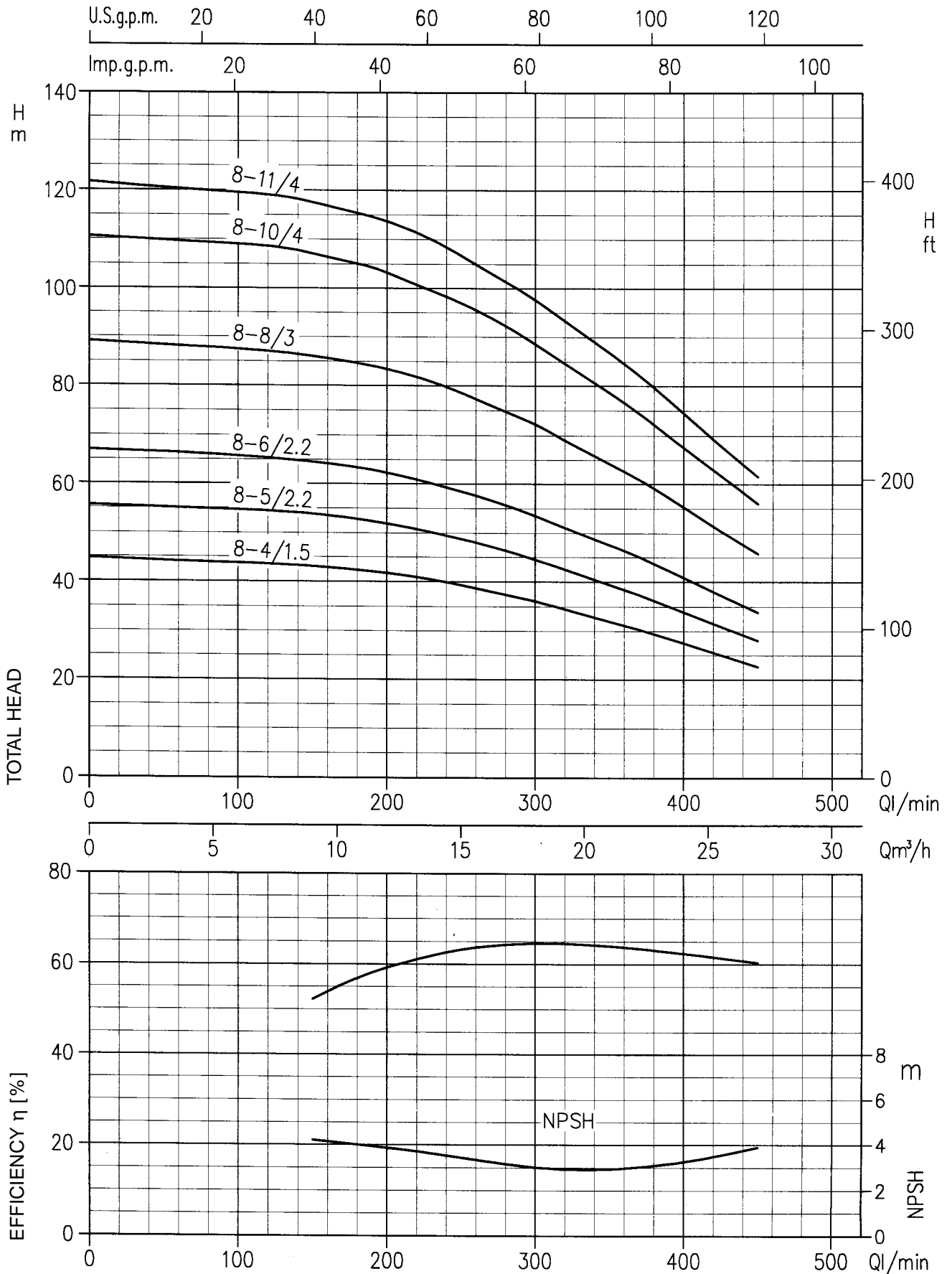

PERFORMANCE CURVES 2GPE EVM 16 (according to ISO 9906 grade 2)

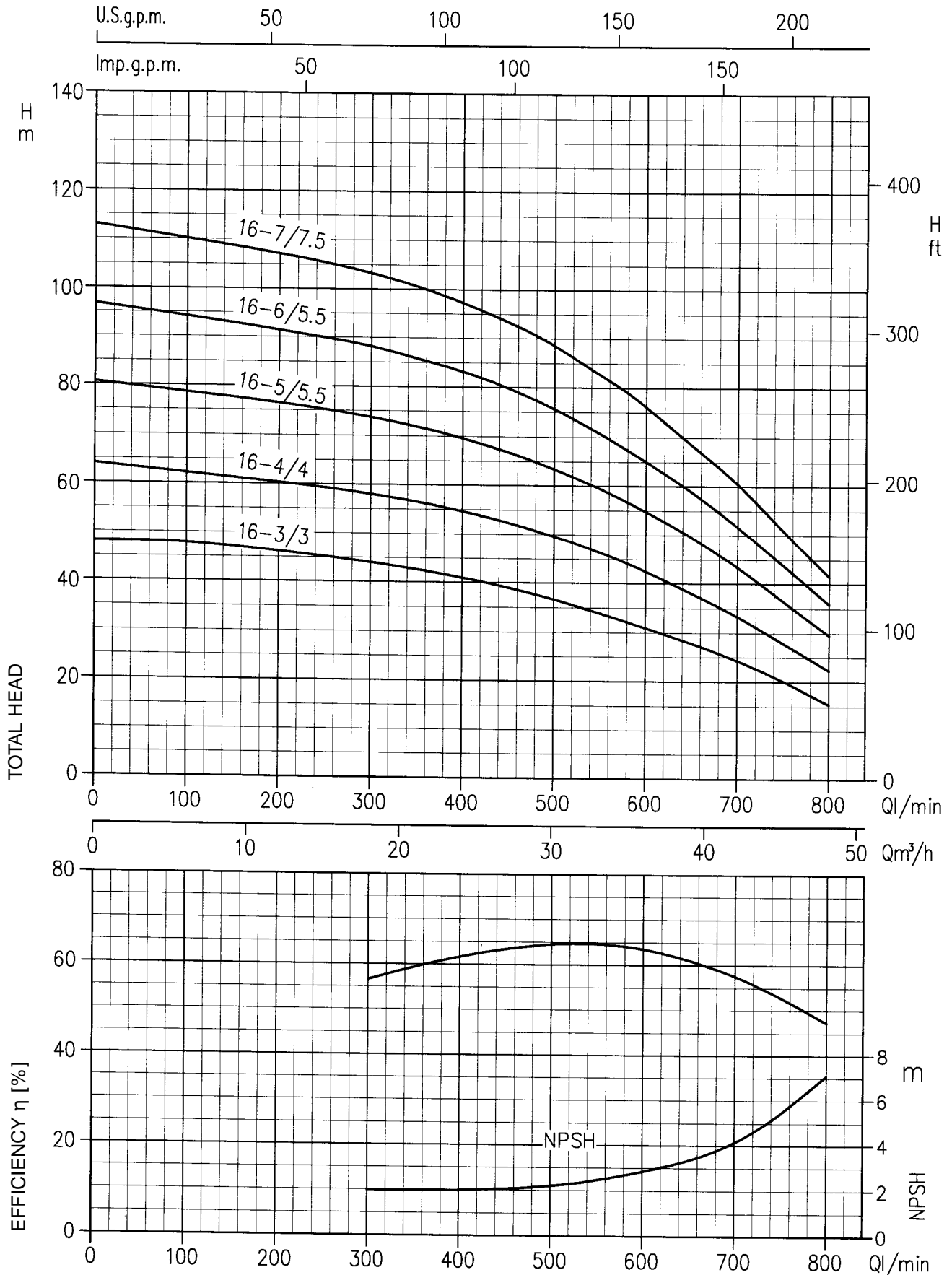

PERFORMANCE CURVES 2GPE EVM(G) 30 (according to ISO 9906 grade 2)

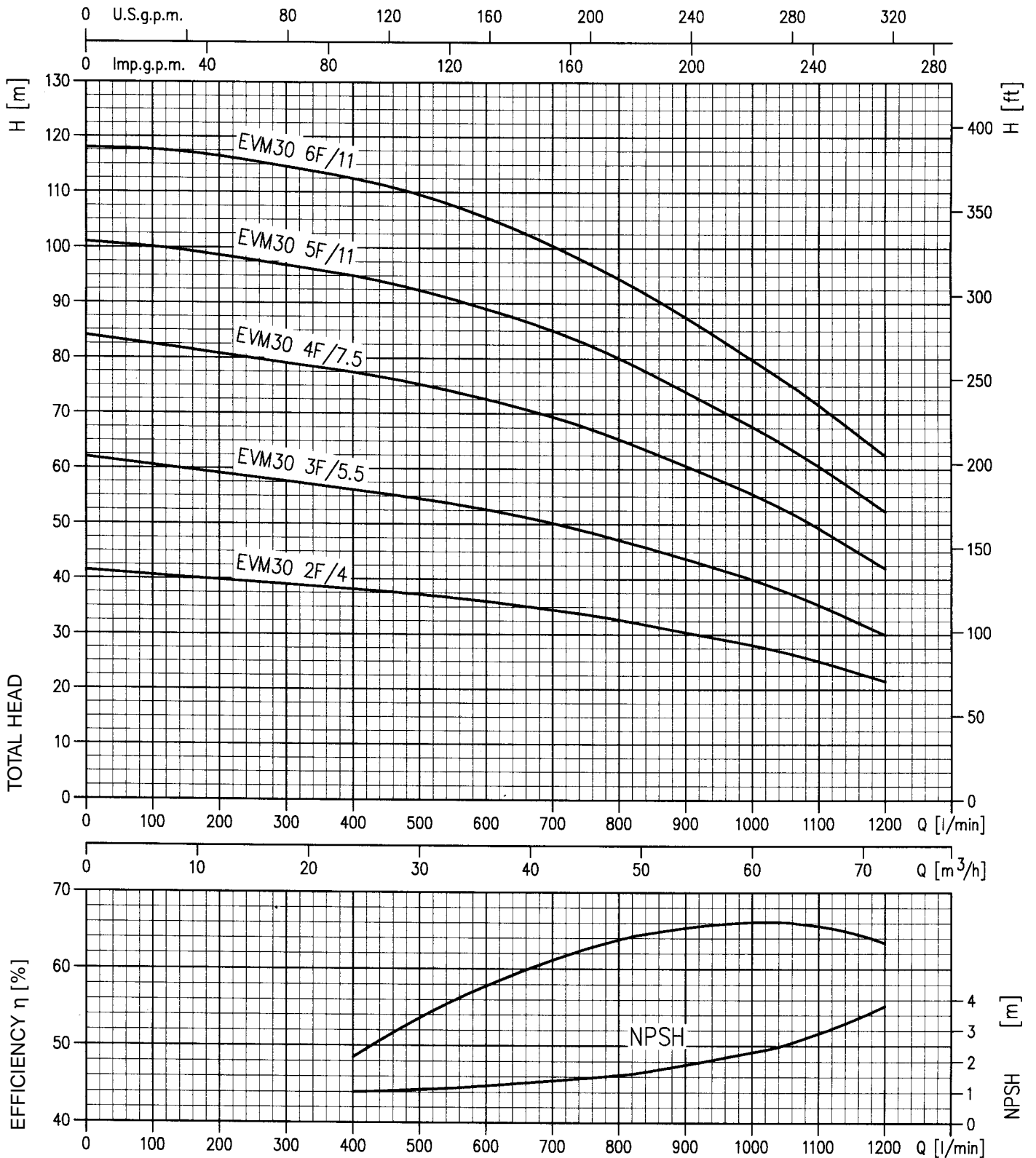

PERFORMANCE CURVES 2GPE EVM(G) 60 (according to ISO 9906 grade 2)

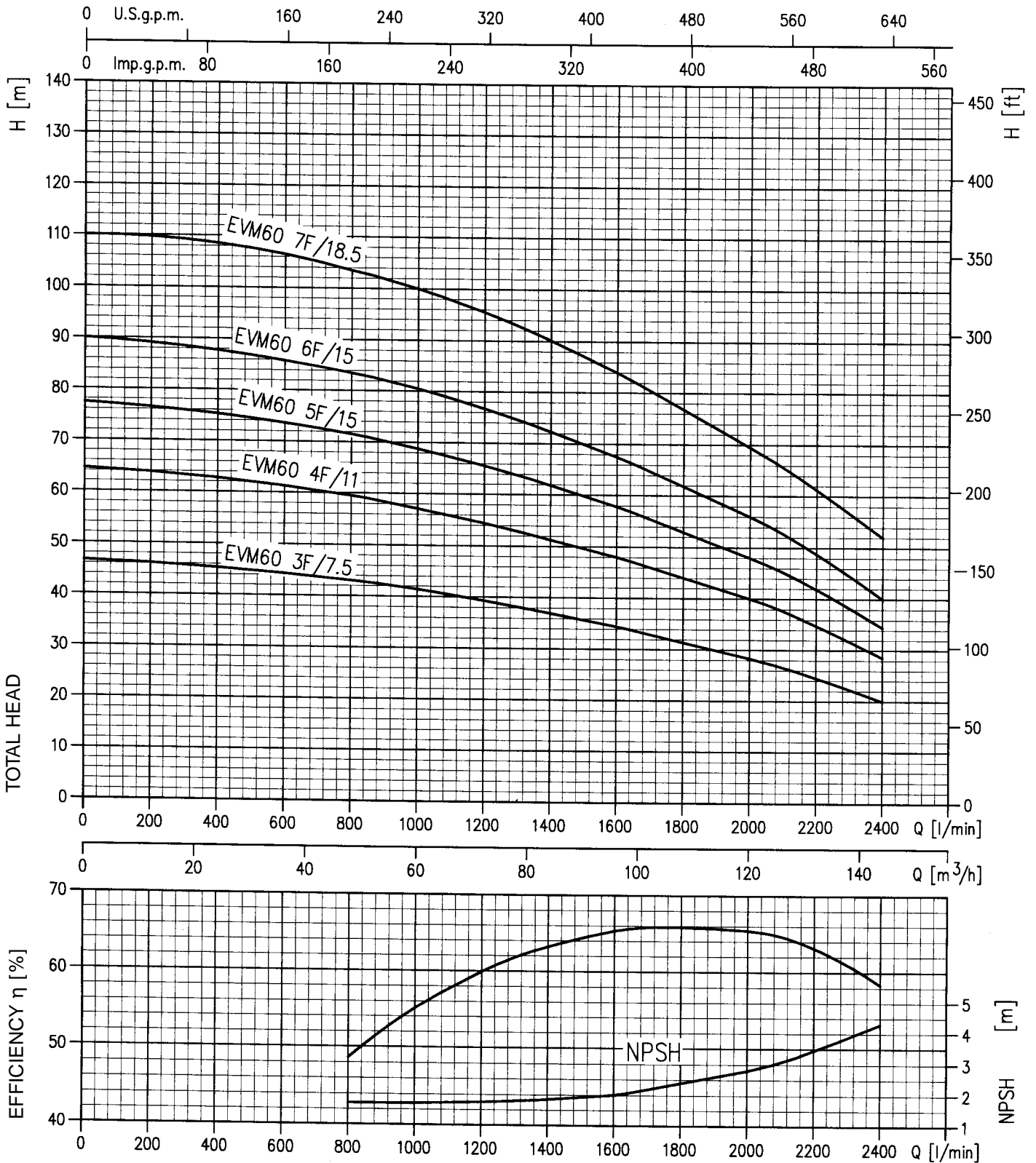

DIMENSIONAL DRAWINGS 2GPE EVM(G)

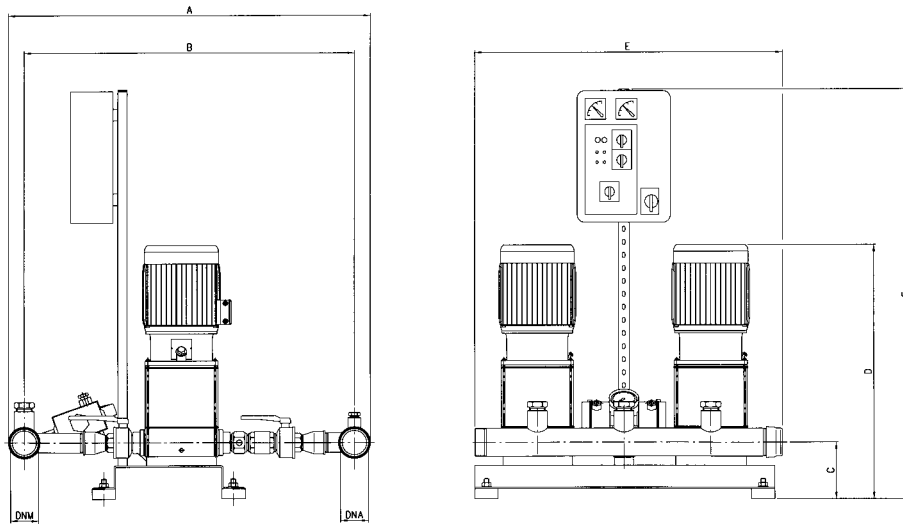

DIMENSIONAL TABLE

Model	Dimensions (mm)							
	A	B	C	D	E	F	DNA	DNM
2GPE EVM2 4N/0,55	660	591	125	528	640	880	2"	2"
2GPE EVM2 5N/0,55	660	591	125	543	640	880	2"	2"
2GPE EVM2 6N/0,75	660	591	125	610	640	880	2"	2"
2GPE EVM2 7N/0,75	660	591	125	631	640	880	2"	2"
2GPE EVM2 9N/1,1	660	591	125	673	640	880	2"	2"
2GPE EVM2 11N/1,1	660	591	125	715	640	880	2"	2"
2GPE EVM4 5N/1,1	686	617	125	623	640	880	2 ¹ / ₂ "	2 ¹ / ₂ "
2GPE EVM4 6N/1,1	686	617	125	651	640	880	2 ¹ / ₂ "	2 ¹ / ₂ "
2GPE EVM4 7N/1,5	686	617	125	693	640	880	2 ¹ / ₂ "	2 ¹ / ₂ "
2GPE EVM4 8N/1,5	686	617	125	721	640	880	2 ¹ / ₂ "	2 ¹ / ₂ "
2GPE EVM4 10N/2,2	686	617	125	804	640	880	2 ¹ / ₂ "	2 ¹ / ₂ "
2GPE EVM4 11N/2,2	686	617	125	832	640	880	2 ¹ / ₂ "	2 ¹ / ₂ "
2GPE EVM4 12N/2,2	686	617	125	915	1030	1000	2 ¹ / ₂ "	2 ¹ / ₂ "
2GPE EVM8 4N/1,5	822	722	155	690	1030	1000	80	80
2GPE EVM8 5N/2,2	822	722	155	747	1030	1000	80	80
2GPE EVM8 6N/2,2	822	722	155	777	1030	1000	80	80
2GPE EVM8 8N/3,0	822	722	155	892	1030	1000	80	80
2GPE EVM8 10N/3,0	822	722	155	982	1030	1000	80	80
2GPE EVM8 11N/4,0	822	722	155	1012	1030	1000	80	80
2GPE EVM16 3F/3,0	1134	914	165	782	1030	1000	100	100
2GPE EVM16 4F/4,0	1134	914	165	822	1030	1000	100	100
2GPE EVM16 5F/5,5	1134	914	165	942	1030	1000	100	100
2GPE EVM16 6F/5,5	1134	914	165	982	1030	1000	100	100
2GPE EVM16 7F/7,5	1134	914	165	1022	1030	1000	100	100
2GPE EVM(G) 30 2F/4	1650	1500	205	903	1200	1800	150	150
2GPE EVM(G) 30 3F/5.5	1650	1500	205	1038	1200	1800	150	150
2GPE EVM(G) 30 4F/7.5	1650	1500	205	1086	1200	1800	150	150
2GPE EVM(G) 30 5F/11	1650	1500	205	1290	1200	1800	150	150
2GPE EVM(G) 30 6F/11	1650	1500	205	1338	1200	1800	150	150
2GPE EVM(G) 60 3F/7.5	1890	1690	240	1163	1200	1800	200	200
2GPE EVM(G) 60 4F/11	1890	1690	240	1390	1200	1800	200	200
2GPE EVM(G) 60 5F/15	1890	1690	240	1462	1200	1800	200	200
2GPE EVM(G) 60 6F/15	1890	1690	240	1534	1200	1800	200	200
2GPE EVM(G) 60 7F/18.5	1890	1690	240	1606	1200	1800	200	200

PERFORMANCE CURVES 3GPE EVM 8 (according to ISO 9906 grade 2)

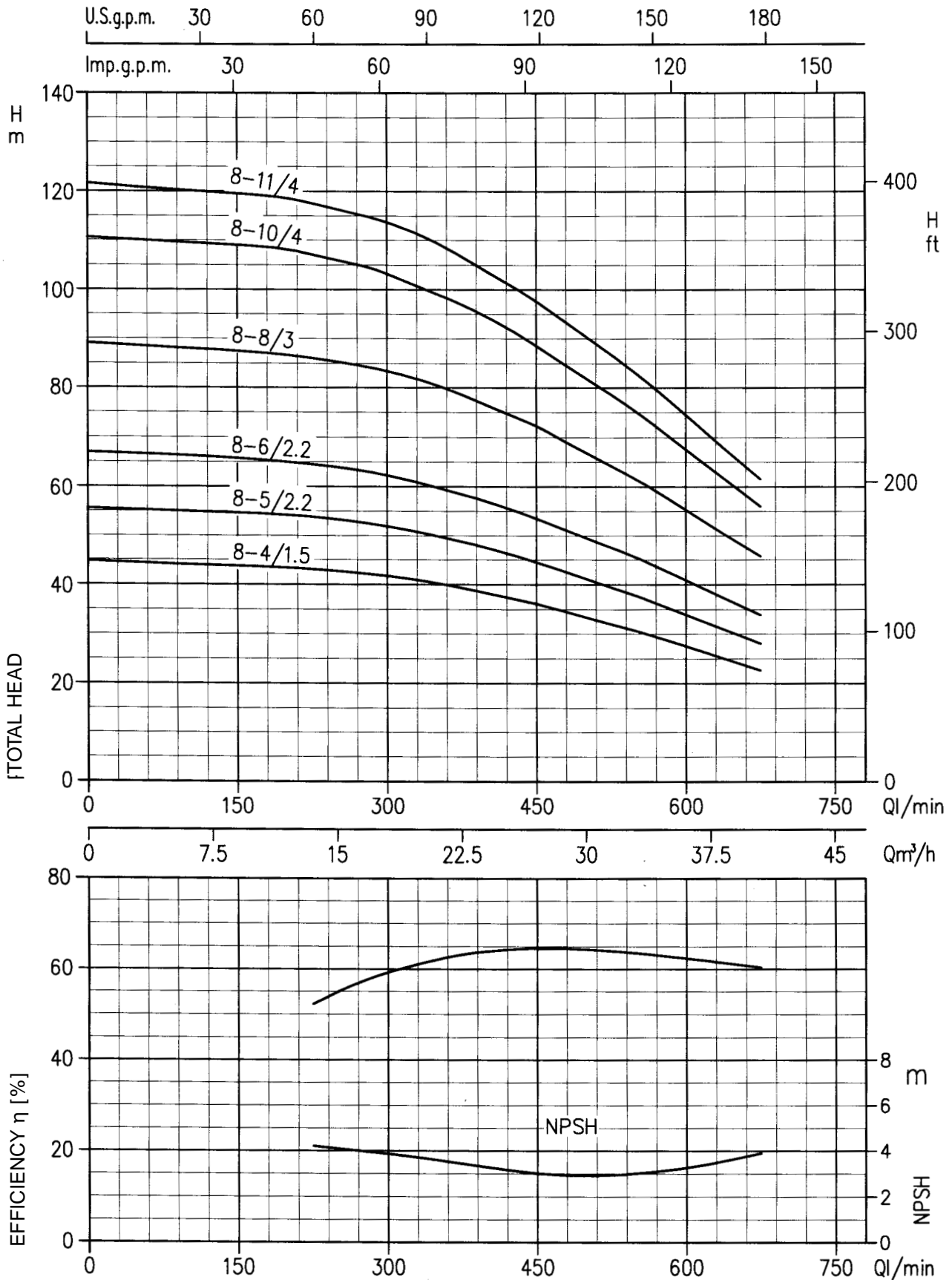

PERFORMANCE CURVES 3GPE EVM 16 (according to ISO 9906 grade 2)

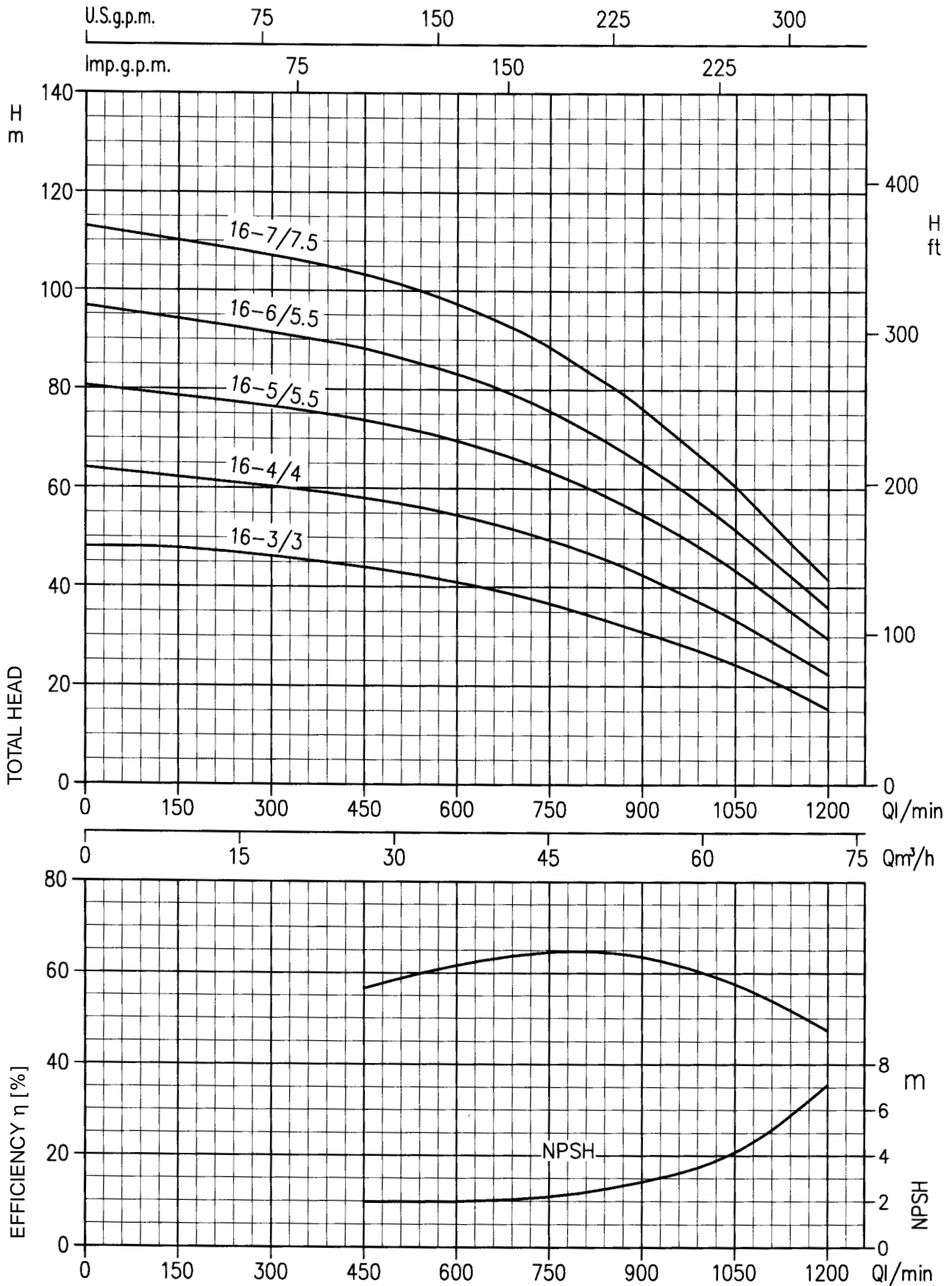

PERFORMANCE CURVES 3GPE EVM(G) 30 (according to ISO 9906 grade 2)

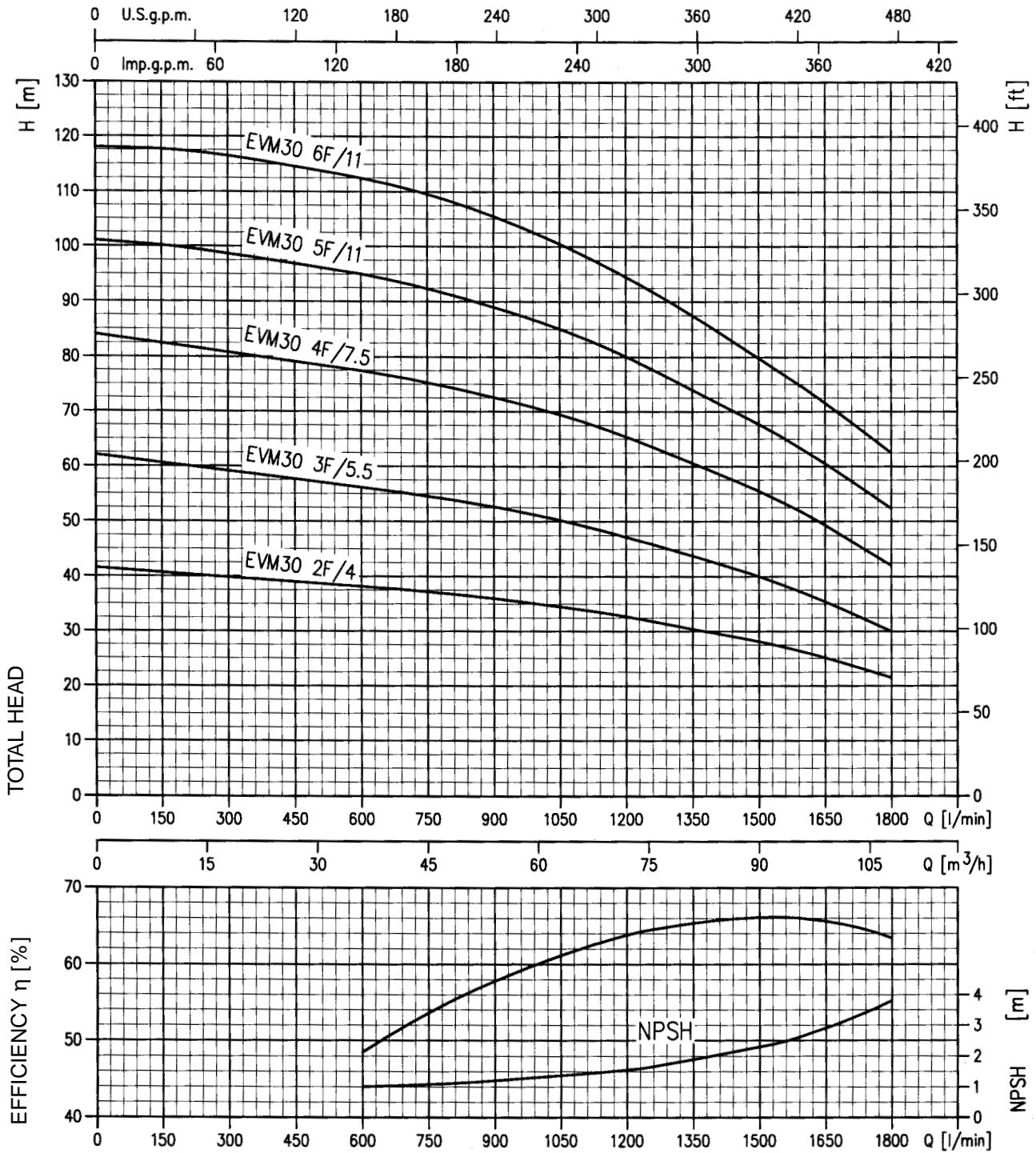

PERFORMANCE CURVES 3GPE EVM(G) 60 (according to ISO 9906 grade 2)

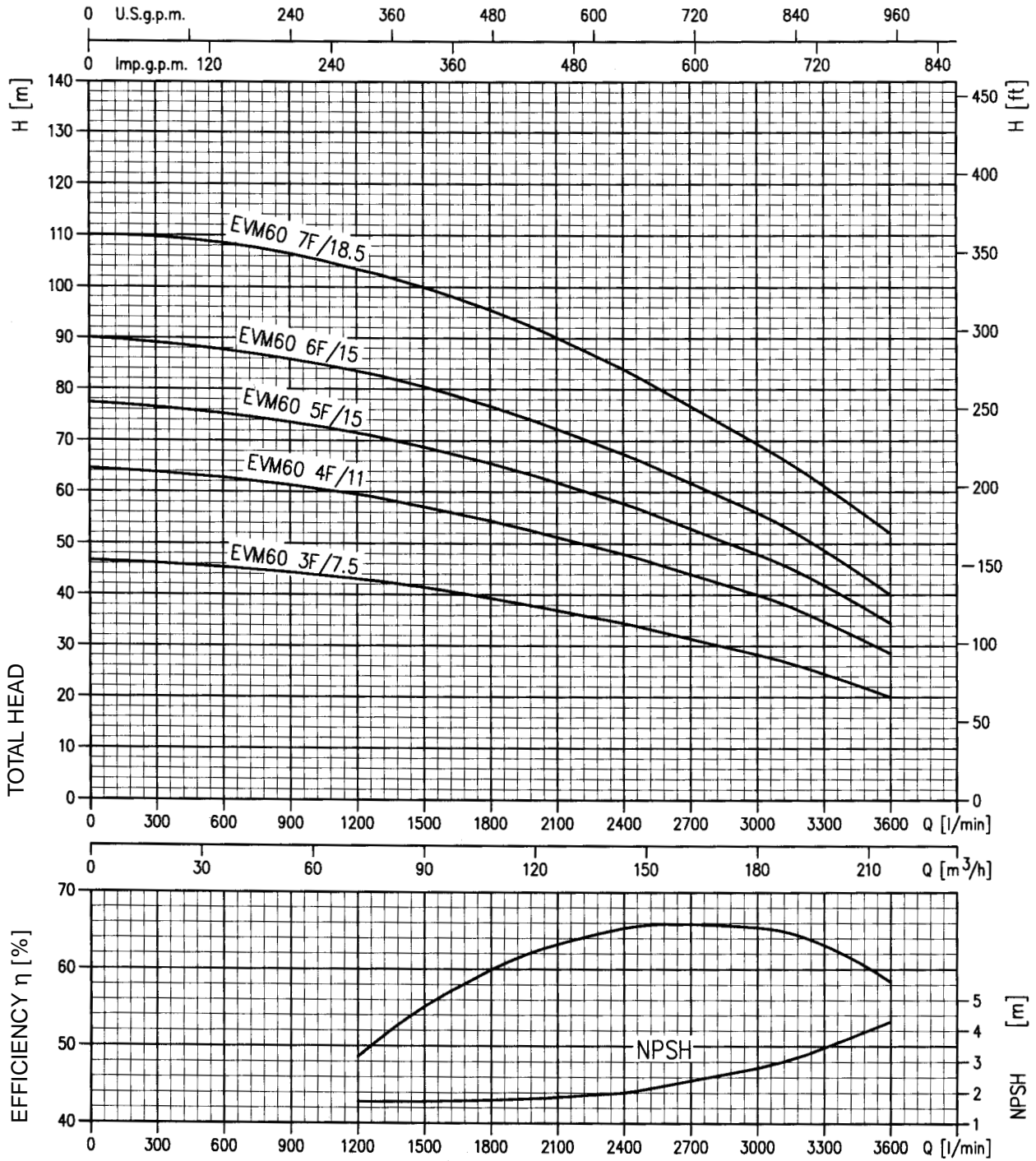

PERFORMANCE TABLE OF THE THREE PUMPS WORKING TOGETHER

Pump type Three phase 400 V	kW	Absorbed current (A)	Q=Capacity														
			l/min	0	240	300	360	450	525	600	675	750	900	1050	1200		
			m ³ /h	0	14,4	18	21,6	27	31,5	36	40,5	45	54	63	72		
			H=Total head [m]														
EVM8 4N/1,5	1,5 + +1,5 + 1,5	9,9	44,5	42,2	41,8	40,0	36,1	31,5	27,7	22,6							
EVM8 5N/2,2	2,2 + 2,2 + 2,2	13,2	55,5	53,0	51,8	49,1	44,3	40,0	34,0	28,3							
EVM8 6N/2,2	2,2 + 2,2 + 2,2	13,2	67,0	64,2	62,0	59,0	53,6	47,0	40,9	33,8							
EVM8 8N/3	3 + 3 + 3	18,9	89,0	85,0	83,2	80,2	72,5	64,8	55,0	45,8							
EVM8 10N/4	4 + 4 + 4	24,6	111,0	106,0	103,2	98,4	87,8	79,8	67,5	56,5							
EVM8 11N/4	4 + 4 + 4	24,6	122,0	116,2	113,2	108,0	97,8	88,0	74,5	61,4							
EVM16 3F/3	3 + 3 + 3	18,9	48,0				43,6	42,0	40,0	38,1	36,0	30,7	23,8	15,4			
EVM16 4F/4	4 + 4 + 4	24,6	64,0				58,2	56,4	54,4	52,0	49,7	42,3	33,4	22,3			
EVM16 5F/5,5	5,5 + 5,5 + 5,5	34,5	81,0				73,8	71,5	69,0	67,1	63,7	54,9	43,6	29,5			
EVM16 6F/5,5	5,5 + 5,5 + 5,5	34,5	97,0				88,3	85,3	82,2	79,8	75,8	65,0	52,3	35,8			
EVM16 7F/7,5	7,5 + 7,5 + 7,5	45,9	113,0				103,3	99,5	96,0	92,5	88,2	76,5	60,0	41,3			

Pump type Three phase 400 V	kW	Absorbed current (A)	Q=Capacity																
			l/min	0	300	450	600	750	900	999	1200	1350	1500	1650	1800	2100	2400	3000	3600
			m ³ /h	0	18	27	36	45	54	60	72	81	90	99	108	126	144	160	216
			H=Total head [m]																
EVM(G) 30 2F/4	4 + 4 + 4	24,6	41,5	39,8	39	38,2	37,6	36,0	34,8	32,7	30,4	28,1	25	21,5					
EVM(G) 30 3F/5,5	5,5 + 5,5 + 5,5	34,5	62	59,1	58	56,2	54,0	52,5	50,5	47,2	44,0	40	35,5	30					
EVM(G) 30 4F/7,5	7,5 + 7,5 + 7,5	45,9	84	80,8	79,8	77,4	75,0	72,6	70,0	65,6	61,0	55,5	49	42					
EVM(G) 30 5F/11	11 + 11 + 11	61,2	101	98,7	97,7	95,0	92,0	89,0	86,0	80,1	75,0	67,7	60	52,3					
EVM(G) 30 6F/11	11 + 11 + 11	61,2	118	116,5	115,0	112,6	109,8	105,4	102,5	94,6	87,0	79,8	71,5	62,5					
EVM(G) 60 3F/7,5	7,5 + 7,5 + 7,5	45,9	46,6	49,4						43,0	42	41,5	40,5	39,3	37	34,5	28,3	19,5	
EVM(G) 60 4F/11	11 + 11 + 11	61,2	64,5							59,5	58	57	56	54,4	52	48	40	28,5	
EVM(G) 60 5F/15	15 + 15 + 15	82,8	77,3							71,5	70	68,5	67	65,6	62,3	57,8	48	34,3	
EVM(G) 60 6F/15	15 + 15 + 15	82,8	90							83,5	82	80	78	76,7	73	67,5	56	40	
EVM(G) 60 7F/18,5	18,5 + 18,5 + 18,5	96	110							103,5	102	100	97,5	95,5	90	84	69,5	52	

DIMENSIONAL DRAWINGS 3GPE EVM(G)

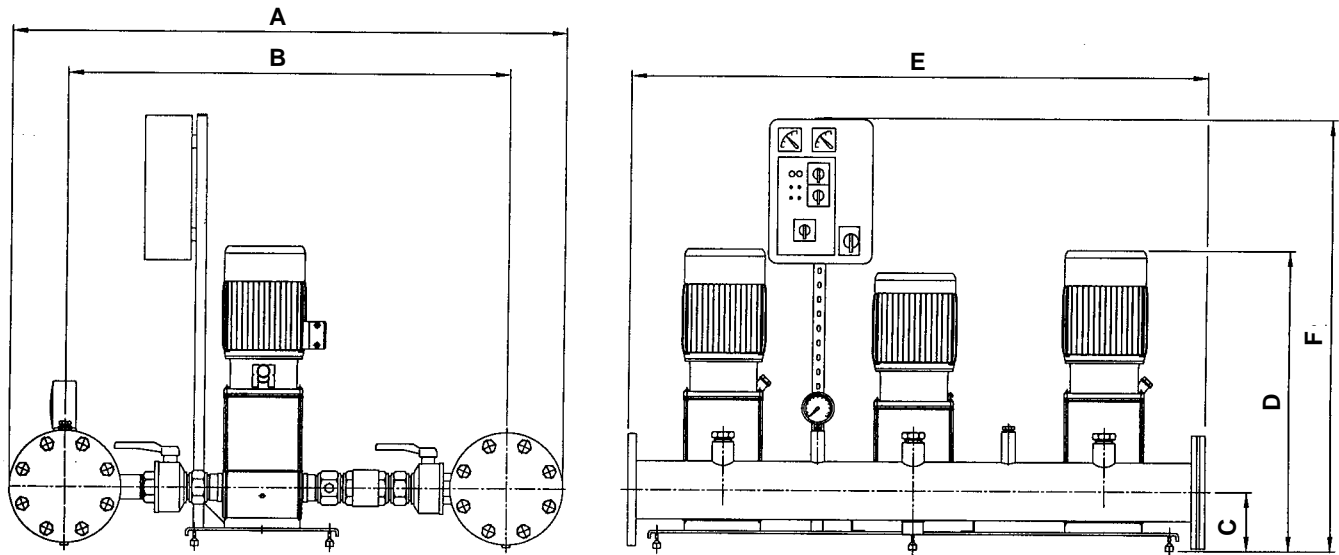

DIMENSIONAL TABLE

Model	Dimensions (mm)							
	A	B	C	D	E	F	DNA	DNM
3GPE EVM2 4N/0.55	720	651	125	528	1030	880	80	80
3GPE EVM2 5N/0.55	720	651	125	543	1030	880	80	80
3GPE EVM2 6N/0.75	720	651	125	610	1030	880	80	80
3GPE EVM2 7N/0.75	720	651	125	631	1030	880	80	80
3GPE EVM2 9N/1.1	720	651	125	673	1030	880	80	80
3GPE EVM2 11N/1.1	720	651	125	715	1030	880	80	80
3GPE EVM4 5N/1.1	720	651	125	623	1030	880	80	80
3GPE EVM4 6N/1.1	720	651	125	651	1030	880	80	80
3GPE EVM4 7N/1.5	720	651	125	693	1030	880	80	80
3GPE EVM4 8N/1.5	720	651	125	721	1030	880	80	80
3GPE EVM4 10N/2.2	720	651	125	804	1030	880	80	80
3GPE EVM4 11N/2.2	720	651	125	832	1030	880	80	80
3GPE EVM4 12N/2.2	720	651	125	915	1030	880	80	80
3GPE EVM8 4N/1.5	862	762	155	690	1030	1000	100	100
3GPE EVM8 5N/2.2	862	762	155	747	1030	1000	100	100
3GPE EVM8 6N/2.2	862	762	155	777	1030	1000	100	100
3GPE EVM8 8N/3	862	762	155	892	1030	1000	100	100
3GPE EVM8 10N/3	862	762	155	982	1030	1000	100	100
3GPE EVM8 11N/4	862	762	155	1012	1030	1000	100	100
3GPE EVM16 3F/3	1184	964	165	782	1500	1000	125	125
3GPE EVM16 4F/4	1184	964	165	822	1500	1000	125	125
3GPE EVM16 5F/5.5	1184	964	165	942	1500	1000	125	125
3GPE EVM16 6F/5.5	1184	964	165	982	1500	1000	125	125
3GPE EVM16 7F/7.5	1184	964	165	1022	1500	1000	125	125
3GPE EVM(G)30 2F/4	1650	1500	205	903	1800	1800	150	150
3GPE EVM(G)30 3F/5.5	1650	1500	205	1038	1800	1800	150	150
3GPE EVM(G)30 4F/7.5	1650	1500	205	1086	1800	1800	150	150
3GPE EVM(G)30 5F/11	1650	1500	205	1290	1800	1800	150	150
3GPE EVM(G)30 6F/11	1650	1500	205	1338	1800	1800	150	150
3GPE EVM(G)60 3F/7.5	1890	1690	240	1163	1800	1800	200	200
3GPE EVM(G)60 4F/11	1890	1690	240	1390	1800	1800	200	200
3GPE EVM(G)60 5F/15	1890	1690	240	1462	1800	1800	200	200
3GPE EVM(G)60 6F/15	1890	1690	240	1534	1800	1800	200	200
3GPE EVM(G)60 7F/18.5	1890	1690	240	1606	1800	1800	200	200